



Download

TITANO

400V SLIDING GATE OPENER

فاتحات البوابات السحاب 400 فولت



USE AND MAINTENANCE MANUAL

دليل الاستخدام والصيانة

هذا الجهاز ليس مخصص للإستخدام من قبل الأشخاص (بما في ذلك الأطفال) الذين يعانون من ضعف في القدرات الجسدية و الحسية أو العقلية

تحذير: تعليمات السلامة الهامة. ومن المهم لسلامة الأشخاص اتباع هذه التعليمات. وفر هذه التعليمات

تحذير: تعليمات السلامة الهامة. اتبع جميع التعليمات لأنّ التثبيت غير الصحيح يمكن أن يؤدي إلى إصابة شديدة



TECHNICAL FEATURES

	QK-T3000	QK-T4000	QK-T6000
إمدادات الجهد (VAC)	400 Three Phase		
إستيعاب الطاقة (W)	700	750	1500
إستيعاب التيار (A)	1,7	2,2	3,7
درجة حرارة التشغيل C°	-30/+70		
سرعة البوابة m/min	11		
مستوى الحماية IP	55		
دورة العمل %	70		
وزن الجهاز / التروس و المحرك kg	40	58	66
السرعة rpm	1400		
نسبة / معدل الإنخفاض	1/30		
أعلى وزن للبوابة kg	3000	4000	6000

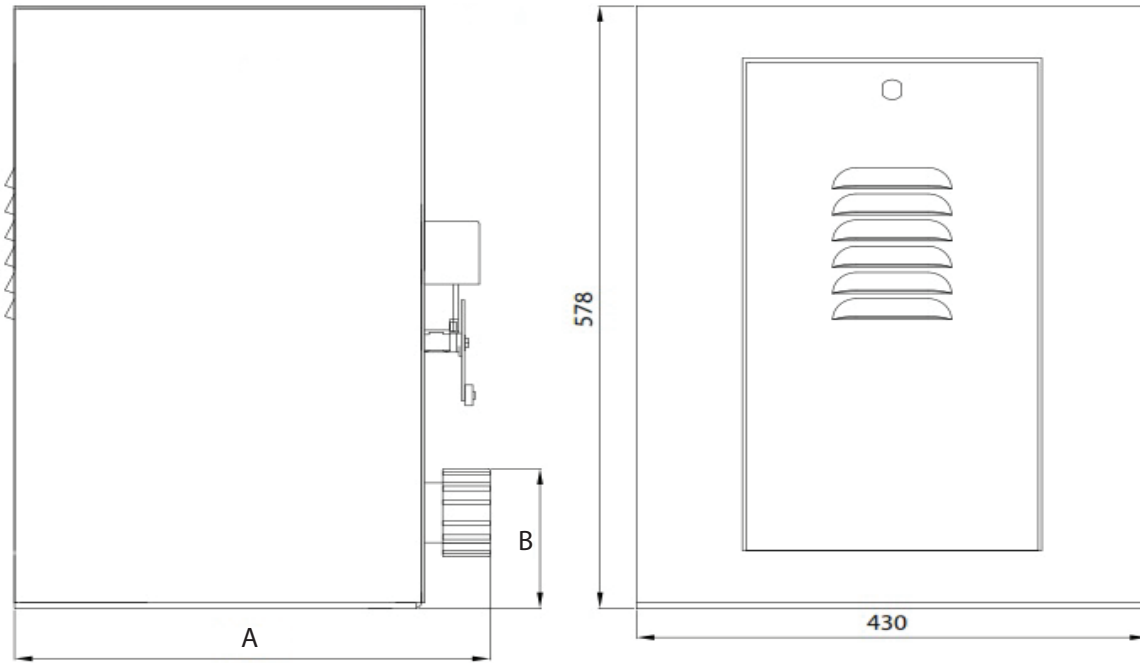

A = 390 (QK-T3000); 400 (QK-T4000/QK-T6000)
 B = 150 (QK-T3000); 130 (QK-T4000); 150 (QK-T6000);

توجيهات قبل التركيب

قبل تثبيت الآلة، يجب التحقق مما يلي

- يتم تثبيت عجلات البوابة لجعل بوابة مستقرة ويجب أن تكون في حالة جيدة
- يجب أن يكون طول المدرج الثابت خال من العوائق، مستقيمة ونظيفة ولها ذراع تحكم في النهايات
- يجب أن يسمح الموجه العلوي، بالتوازي مع السكك الحديدية وأن تعمل بسلاسة، و ترك فسحة فارغة حوالي 1 ملم من الباب
- كويكو إيطاليا ساس مسؤولة عن المنتجات التي تقوم بتصنيعها وتسويقها فقط . تلقائياً

تحذير

كويكو إيطاليا ساس ليست مسؤولة عن أي اضرار تصيب البشر او الحيوانات أو البوابة نفسها في حال تم التركيب بصورة مخالفة للتعليمات و هي غير مسؤولة أيضا عن أي تعديلات يقوم بها أي طرف آخر على المنتج

مواد التثبيت

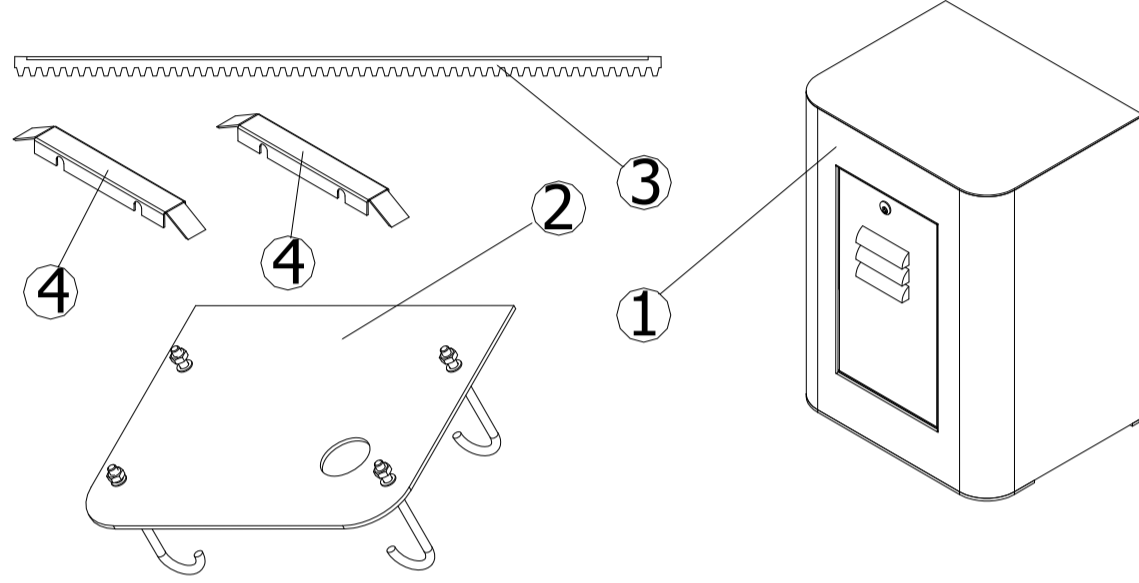

Fig. 1

1. الجهاز / الموتور
2. قاعدة التثبيت (إضافة إختيارية QK-CPT)
3. السكة الحديدية M6 30X30mm
4. تحديد مستوى الفتح و الإغلاق

وضعية قاعدة تثبيت الجهاز

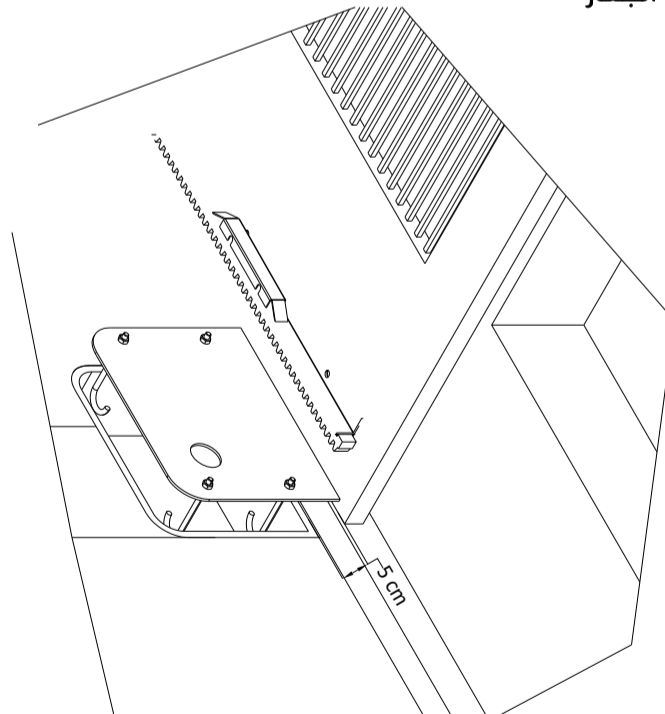

Fig. 2

تركيب الجهاز / الموتور / التروس

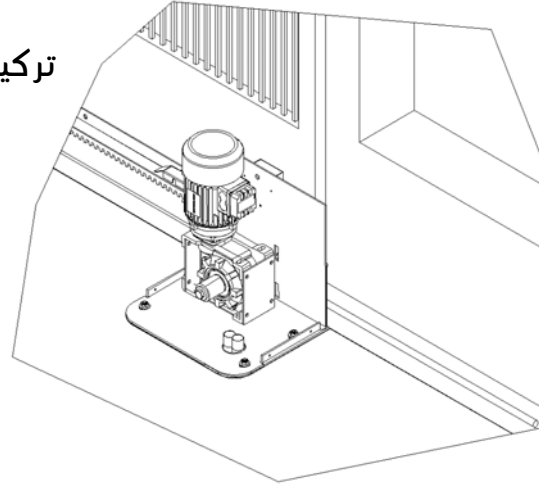
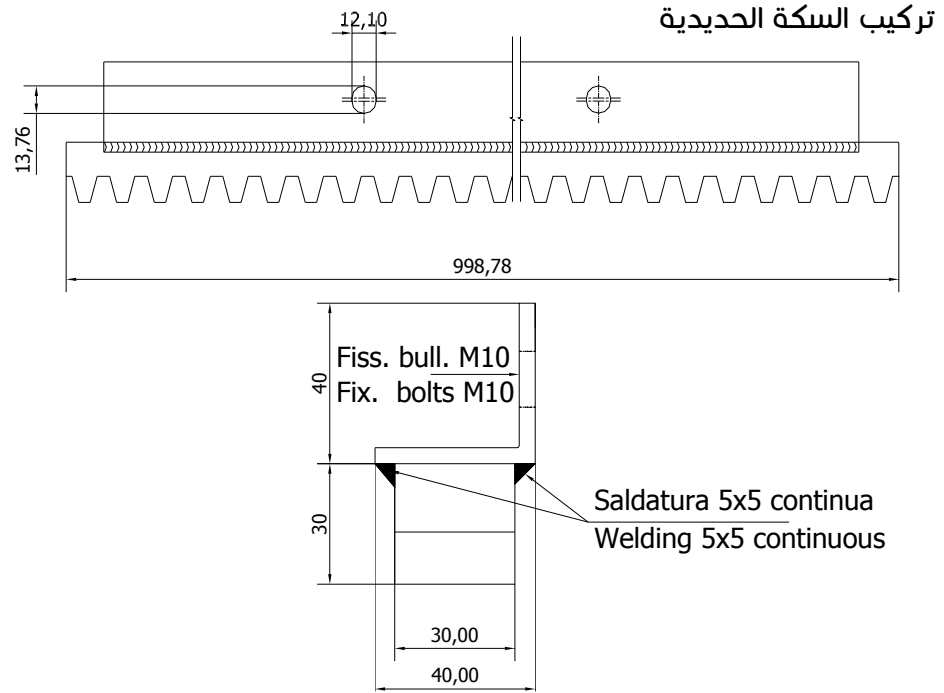

Fig. 3

قم بإزالة غطاء الجهاز عن طريق فك البراغي الأربعة (السمونة) باستخدام مفتاح مناسب ، ثم قم بتركيب الجهاز / الموتور على لوحة التثبيت

يجب أن يتم ضبط الجهاز / الموتور

- أفقيا: على طول فتحة قاعدة جيرموتور ، حوالي 20 ملم -
- عموديا (إذا لزم الأمر): عن طريق البراغي (السمونة) مستوى 4 وعن طريق إدراج الفواصل -



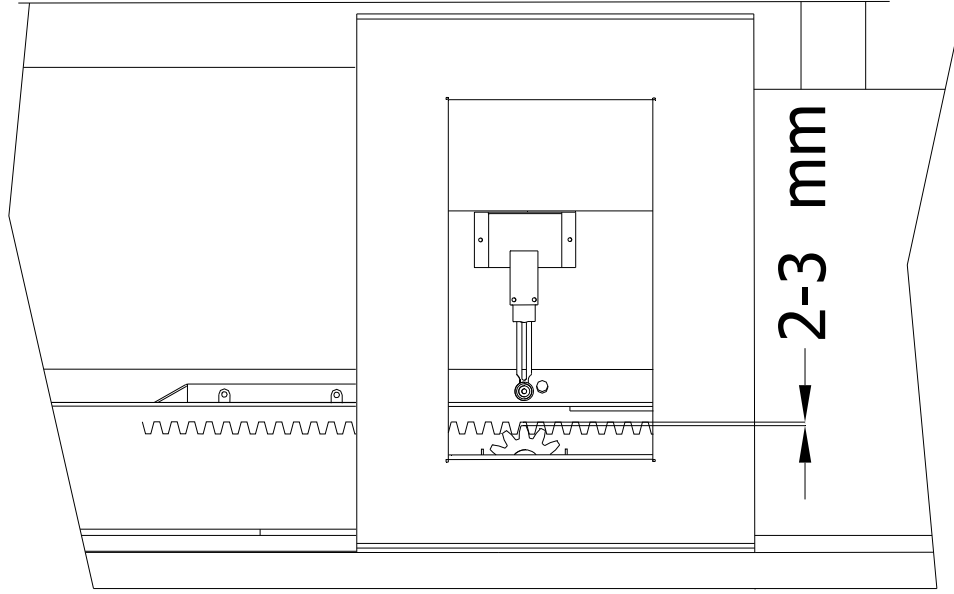

Fig. 5

وضعية محدد مستوى الفتح و الإغلاق

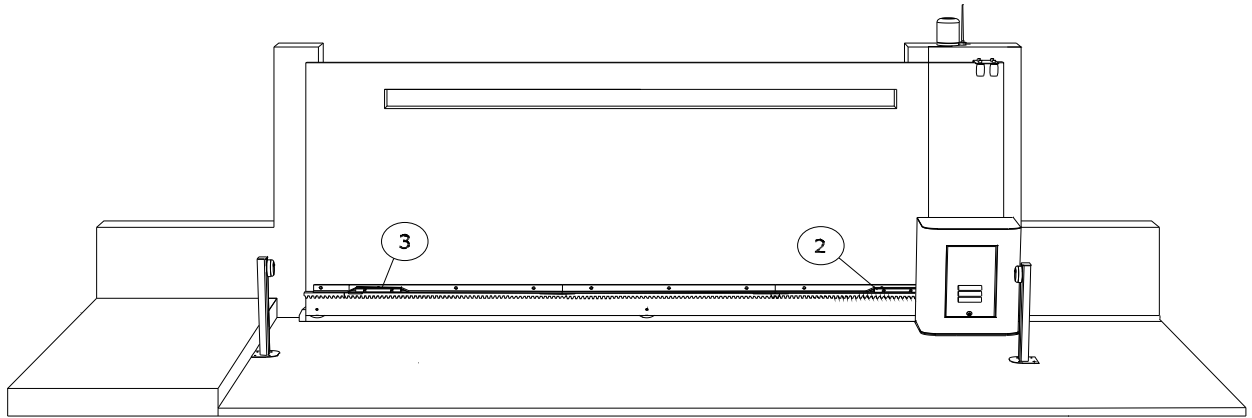

Fig. 6

فتح البوابة يدويا و قم بتثبيت محدد مستوى الفتح / الإغلاق (2) (3) على السكة الحديدية

إستخدام محرر القابط اليدوي

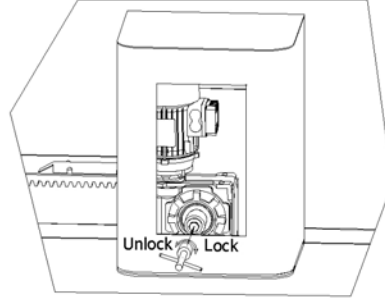

Fig.7

تعليمات التحرير

في حالة وجود خلل أو انقطاع التيار الكهربائي، افتح الباب القابل للإزالة وفتح التروس عن طريق مفك أو عتله في إتجاه عقارب الساعة. هذا يسمح بتحريك البوابة يدويا. تنبيه : قم بعملية التحرير اليدوي بعد التأكد من فصل التيار الكهربائي عن الجهاز / الموتور

تعليمات الإغلاق

لقفل المحرك ، قم بتدوير الترس في اتجاه عكس عقارب الساعة، ثم قم بإحكام التشديد، وأعد إغلاق الغطاء القابل للإزالة

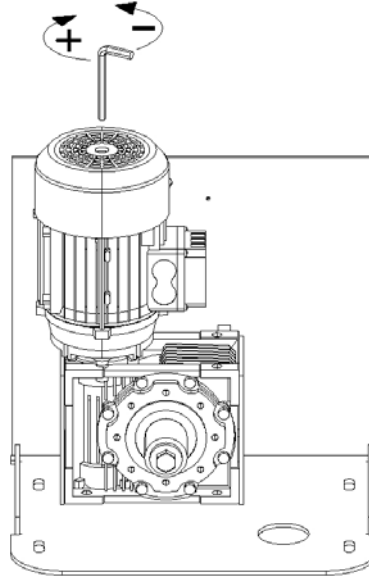

ضبط القابض

Fig. 8

fig.8. ضبط القابض إستنادا لـ

◀ IF THE GEARMOTOR IS PROVIDED WITH THE QK-CE220RLINV CONTROL BOARD **THE CLUTCH CAN BE DISACTIVATED BY TIGHTENING THE BOLT COMPLETELY**

TYPICAL INSTALLATION

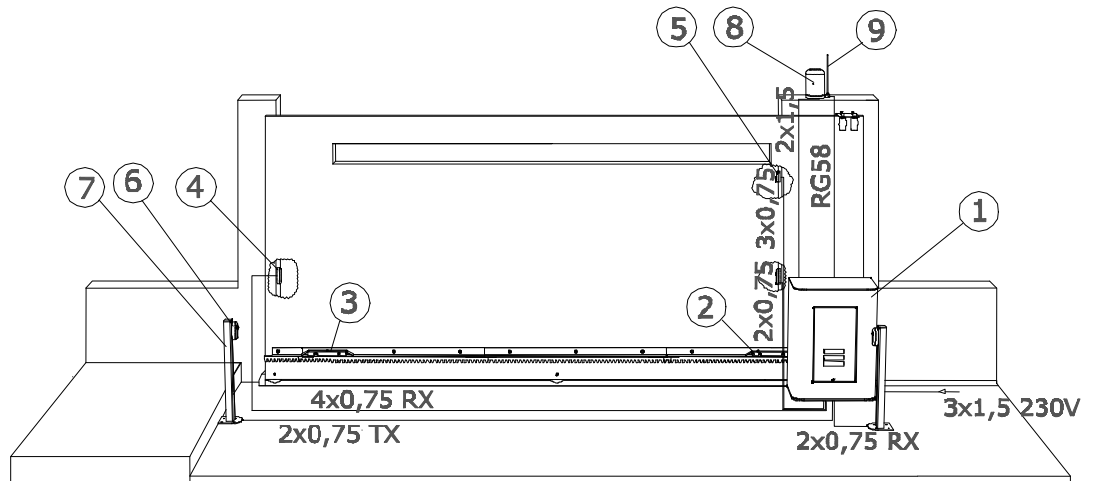

Fig. 9

MAIN COMPONENTS

- 1 - GEAR MOTOR
- 2 - CLOSING LIMIT SWITCH CAMME
- 3 - OPENING LIMIT SWITCH CAMME
- 4 - PHOTOCCELL
- 5 - KEY SELECTOR
- 6 - PHOTOCCELL ON POSTS
- 7 - PHOTOCCELL POST
- 8 - FLASHING LAMP
- 9 - AERIAL

For all electrical connections see the Control Board INSTALLATION MANUAL

QK-CE220RLX CONTROL BOARD FOR SINGLE-PHASE / THREE-PHASE MOTORS

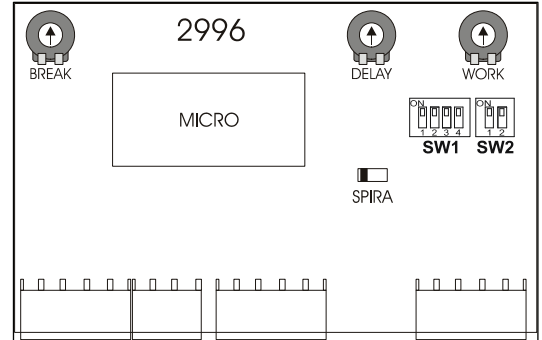
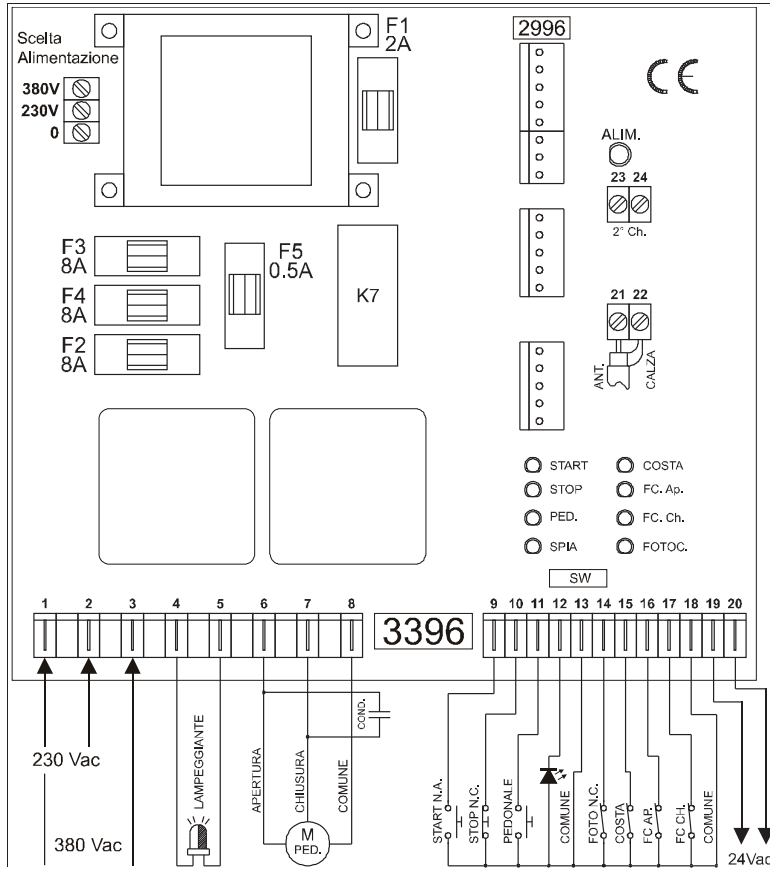

GENERAL ADVICE

QK-CE220RLX is a control board used for automation of heavy duty sliding gates. Suitable for a connection with a clock (timer) which can be connected to the start single input for timely controlled openings / closings. QK-CE220RLX control board is in compliance with the following directives: EMC 2004/108/EC, BT 2006/95/EC and RADIO SETS 1999/05/EC.

TECHNICAL FEATURES

Dimensions	260 x 210 x 100 mm IP55
Absorbed power	3W
24V fuse (F1)	2A
230V fuse (F2, F3, F4)	8A
Flashing lamp fuse (F5)	0,5A
Operating temperature	-30/+70°C
Motor relay contacts	16 A

ADVICES AND SUGGESTIONS FOR INSTALLATION

ATTENTION:

It is necessary to respect the polarity of the phases in the 230VAC connection (connector 1 = phase, connector 2 = neutral).
The n. c. contacts (limit switches, photocells and stop push button) if not used, must be connected to the common (connector 13) using bridges.

CONNECTIONS TABLE

1 - 2 ALIMENT.	230 Vac 50Hz mains power supply (1 phase, 2 neutral)	12 - 13 SPIA	Opened gate lamp / courtesy lamp output (see dip switch).
1 - 2 - 3 ALIMENT.	380 Vac three-phase 50Hz mains power supply	14 - 18 FOTO	Photocell input (n.c. contact). It stops and reverses the motor and it is only enabled during closing.
4 - 5 FLASH	Flashing light output (fixed). 230 Vac max 100 W	15 - 18 COSTA	Safety edge input (n.c. contact) . It stops and reverses for 10cm the motor and it is only enabled during opening.
6 - 7 - 8 M	230/380 Vac 1 KW Max 1 HP motor output (7 close, 8 common, 6 open)	17 - 18 FC AP.	Opening limit switch input (n.c. contact).
9 - 13 START	Start signal (n.o. contact) . During opening it stops. During closing it stops and reverses. If "OPEN ONLY" function is enabled (see page 2) this contact will work as OPEN ONLY.	16 - 18 FC CH.	Closing limit switch input (n.c. contact)
10 - 13 STOP	Stop signal (n.c. contact). It always stops the motor. If pushed during pause it disables the automatic closing.	19 - 20 ALIMENT.	24 Vac 500mA accessories power supply
11 - 13 PED.	Pedestrian start signal (n.o. contact). It performs the partial opening adjustable by means of delay trimmer. If "CLOSE ONLY" function is enabled (see page 2) this contact will work as CLOSE ONLY.	21 - 22	Not used
380 230 0	Mains voltage selection: 230 Vac 0 - 230 380 Vac 0 - 380	23 - 24	Not used

FINAL TESTING

- ◆ Check the connections of the motor bearing in mind that at first start up the motor should open.

SETTING THE DIP-SWITCHES

ATTENTION: The dip switches should be programmed when the control board is switched off.

		ON	OFF
SW1	1	Slide gate mode	Not used
	2	Courtesy lamp mode enabled (90 seconds).	Opened gate lamp mode enabled.
	3	Condominium mode enabled. It doesn't accept start signals during opening. If a start signal is given during pause, the pause time gets reset and the gate closes.	Condominium mode disabled
	4	Automatic closing enabled.	Automatic closing disabled.
SW2	1	Not used	Not used
	2	Electric lock release function enabled	Electric lock release function disabled

WORKING TIME SETTING:

- 1) Make sure that the dip switch SW1 - 1 is on.
- 2) Adjust the WORK trimmer to modify the working time. It is possible to set it from 4" to 200".
- 3) It is possible to use the pedestrian opening (partial opening), adjustable by means of DELAY trimmer (from 2" to 15").

AUTOMATIC CLOSING TIME SETTING (PAUSE TIME):

- 1) Make sure that the dip switch SW1 - 4 is on.
- 2) Adjust the BREAK trimmer to modify the automatic closing pause time. It is possible to set it from 4" to 90".

OPEN ONLY AND CLOSE ONLY FUNCTION SETTING

Inserting a diode in the SPIRA connector, considering the polarity, it is possible to assign to the START button the OPEN ONLY function and to the PEDESTRIAN start button the close only function. Step-by-step function would then be disabled

RADIO RECEIVER CONNECTION

For the connection of the radio receiver refer to the user manual of the QK-R02.

GENERAL ADVICE

Install a gate's safety system that complies with current regulations. Choose short routes for cables and keep power cables separate from control ones. Install the control card in a waterproof box. Please refer to current regulations when setting the gear motor's maximum torque. We advise you to install an outdoor switch, in compliance with European standards on the issue of safety, to turn the electricity off when servicing the gate. Check that each single installed device is efficient and effective. Affix easily readable signs warning about the presence of a motorised gate.

USE

It is absolutely forbidden to use the device for any other purposes. The installed electronic unit (which must have built-in electric friction), allows to select the following functions:

automatic: one control impulse will open or close the gate;
semi-automatic: one control impulse will open or close the gate.

In case of a blackout, manual operation is possible by activating the unlocking device. Having an automatic and electric power device requires special attention in a few situations:

- not to touch the device with wet hands and/or wet or bare feet;
- to turn off electricity before opening the control box and/or actuator;
- not to pull the lead to pull the plug out;
- to put the gate in movement only when it is completely visible;
- to keep out of the gate's range of action if it is moving. Wait until it has stopped;
- not to let children or animals play near the gate;
- not to let children use the remote control or other operating devices;
- to carry out routine maintenance;
- in case of failure, to turn off electricity and operate the gate manually only if it is possible and safe. Refrain from touching the gate and call an authorised technician.

MAINTENANCE

The TITANO SERIES geared motors are manufactured for long-term use. Nonetheless, their normal operation can be compromised by the conditions of the gate; therefore, we will list some operations to keep the gate efficient.

Warning: Non-specialized staff cannot operate the gate during maintenance. You are advised to cut the network power in order to avoid accidents or shocks. If the power must be on for various inspections, you are advised to check and/or deactivate any possible control devices (remote controls, keyboards, etc...) except for the device used by the maintenance operator.

Routine maintenance

Each of the following operations must be done when needed and in all cases at least every 6 months:

Gate

- Lubricate the gate's sliding wheels;
- Check the cleanliness and air-tightness of the rack.

Automation System

- Check the operation of the safety devices (photo-cells, ribs, torque limiter) using the methods described by the suppliers

Extraordinary Maintenance

If special maintenance is required for mechanical parts, you are advised to send the gear motor out for repairs to be performed by the technicians at the manufacturer.

EU Declaration of Conformity

and Declaration of Incorporation of "quasi-machines" (pursuant to the Machinery Directive 2006/42/CE, Att.II, B)



Company name:	QUIKO ITALY SRL
Postal address:	Via Seccalegno, 19
Postcode and City:	36040, Sossano (VI) - Italy
Telephone number:	+39 0444 785513
E-Mail address:	info@quikoitaly.com

declare that the DoC is issued under our sole responsibility and belongs to the following product:

Apparatus model/Product:	Titano: QK-T30004; QK-T40004; QK-T60004;
Type:	AUTOMATIONS FOR SLIDING GATES (400V)
Batch:	See the label on the motor

The object of the declaration described above is in conformity with the relevant Union harmonisation legislation:

- **Directive 2006/42/CE (MD Directive)**

- It is declared that the relevant technical documentation has been drawn-up in compliance with attachment VII B.
- It is also declared that the following essential health and safety requirements have been respected: 1.1.1 - 1.1.2 - 1.1.3 - 1.1.5 - 1.2.1 - 1.2.6 - 1.3.1 - 1.3.2 - 1.3.3 - 1.3.4 - 1.3.7 - 1.3.9 - 1.5.1 - 1.5.2 - 1.5.4 - 1.5.5 - 1.5.6 - 1.5.7 - 1.5.8 - 1.5.10 - 1.5.11 - 1.5.13 - 1.6.1 - 1.6.2 - 1.6.4 - 1.7.2 - 1.7.3 - 1.7.4 - 1.7.4.1 - 1.7.4.2 - 1.7.4.3.
- The undersigned declares that the afore-mentioned "partly-completed machinery" cannot be commissioned until the final machine, into which it has been incorporated, has been declared compliant with the Machinery Directive 2006/42/CE.
- On duly justified request, the manufacturer commits to transmitting the information regarding the "partly-completed machinery" to the national authorities without prejudice to their intellectual property rights.

- **Directive 2014/53/EU (RED Directive)**

- **Directive 2011/65/EU (RoHS)**

The following harmonised standards and technical specifications have been applied:

Title:	Date of standard/specification
EN 61000-6-2	2005 + AC:2005
EN 61000-6-3	2007 + A1:2011+AC:2012,
EN 301 489-1 V2.2.3	2019
EN 301 489-3 V2.1.1	2017
EN 60335-2-103	2015
EN 12453	2017
EN 62479	2010
EN 300 220-2 V3.1.1	2017
EN IEC 63000	2018

Additional information

Signed for and on behalf of:		
Revision:	Place and date of issue:	Name, function, signature
01.00	GG/MM/AAAA	(Borinato Luca, Legal Officer)
	Sossano, 28/09/2021	



QUIKO ITALY

Via Seccalegno, 19

36040 Sossano (VI) - Italy

Tel. +39 0444 785513

Fax +39 0444 782371

info@quikoitaly.com

www.quikoitaly.com

