



Download

E
N
G
L
I
S
H

use and maintenance manual

TITANO

AUTOMATIONS FOR SLIDING GATES (400V)



quirolö[®]
opening solutions

TECHNICAL FEATURES

		QK-T3000	QK-T4000	QK-T6000
VOLTAGE SUPPLY	(VAC)	400 Three Phase		
POWER ABSORBED	(W)	700	750	1500
CURRENT ABSORBED	(A)	1,7	2,2	3,7
OPERATING TEMPERATURE	C°	-30/+70		
GATE SPEED	m/min	11		
PROTECTION LEVEL	IP	55		
WORKING CYCLE	%	70		
GEARMOTOR WEIGHT	kg	40	58	66
SPEED	rpm	1400		
REDUCTION RATIO		1/30		
MAX. GATE WEIGHT	kg	3000	4000	6000

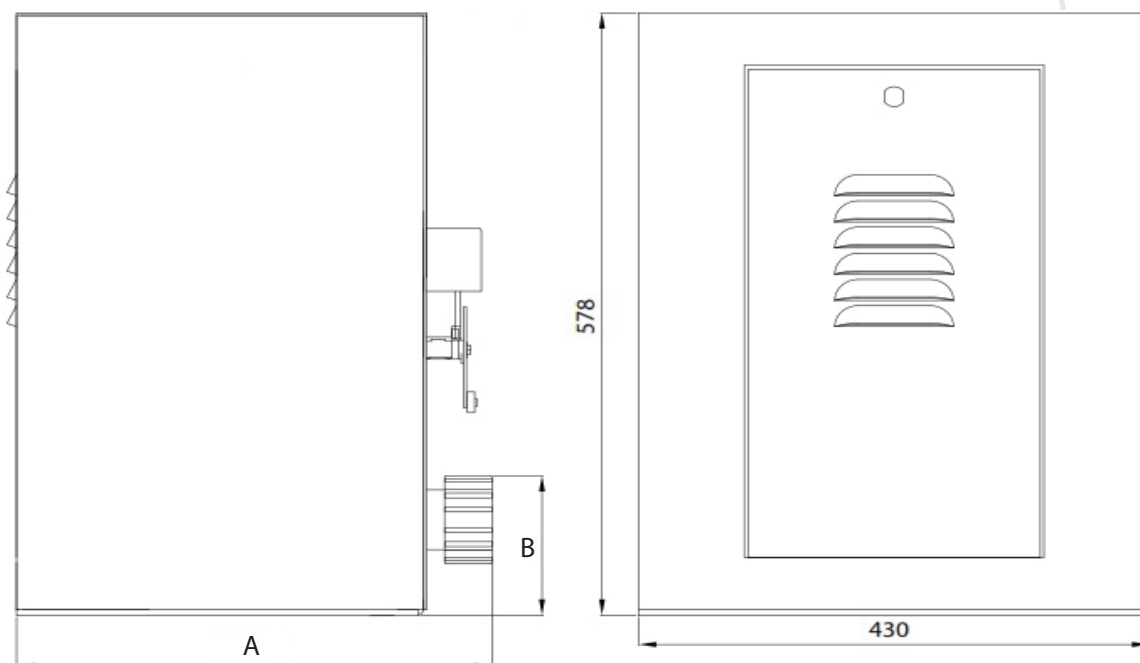

A = 390 (QK-T3000); 400 (QK-T4000/QK-T6000)
 B = 150 (QK-T3000); 130 (QK-T4000); 150 (QK-T6000);

PRE-INSTALLATION CONTROL

Before installing the automation, you must check that:

- The wheels of the gate are attached to make the gate stable and must be in good condition;
- The entire length of the fixed runway must be free of obstacles, straight and clean and have control levers at the ends;
- The upper guide, parallel to the rail and lubricated, must allow for a clearance of about 1 mm from the door

Quiko Italy Sas is liable only for products it manufactures and commercializes. Once automated, the gate becomes a machine and is therefore subjected to the rules of the " Machinery Directive". It is on the installer to verify its security. **WARNING:** Quiko Italy Sas is not liable for any damages to people, animals or things due to unauthorised modifications, alterations or betterments on its products by third parties.

MATERIALS FOR INSTALLATION

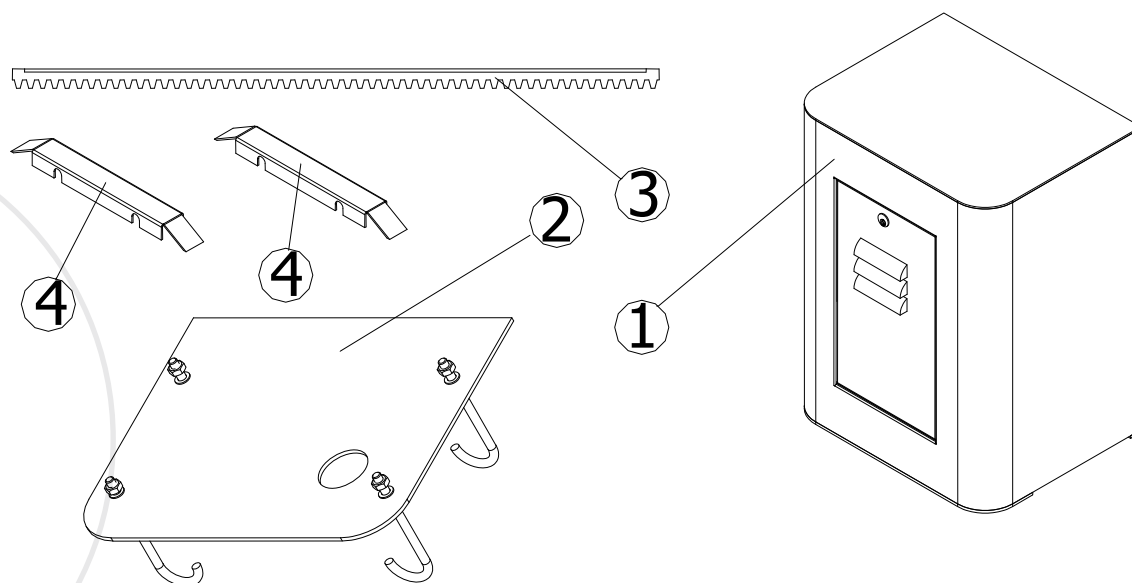

Fig. 1

1. Gear-motor
2. Counterplate (OPTIONAL QK-CPT)
3. M6 iron rack 30x30mm
4. Limit switch cammes

POSITIONING OF THE COUNTERPLATE

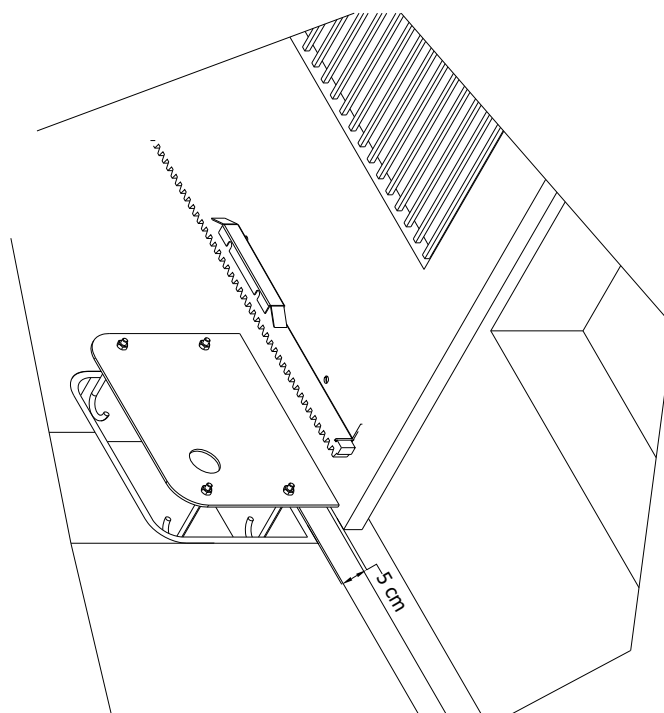

Fig. 2

INSTALLATION OF THE GEARMOTOR

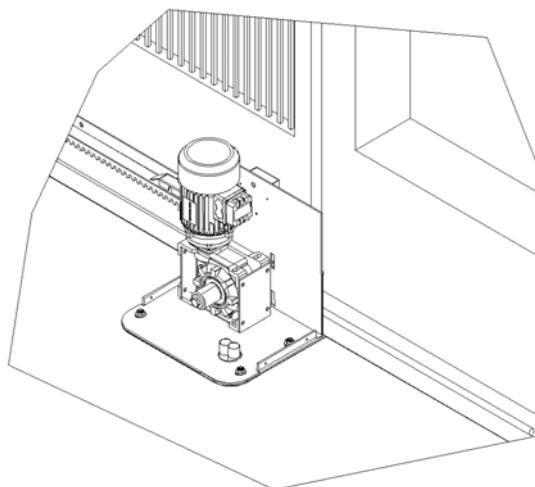

Fig. 3

Open the removable cover of the gearmotor. Loosen the four screws and remove the case. Remove the nuts used to fasten the anchoring brackets. Position the gearmotor onto the counterplate.

The gearmotor has to be adjusted:

- Horizontally: along the gearmotor base slot (approx. 20 mm).
- Vertically (if necessary): by means of the 4 level nuts and by inserting the spacers.

INSTALLING THE RACK

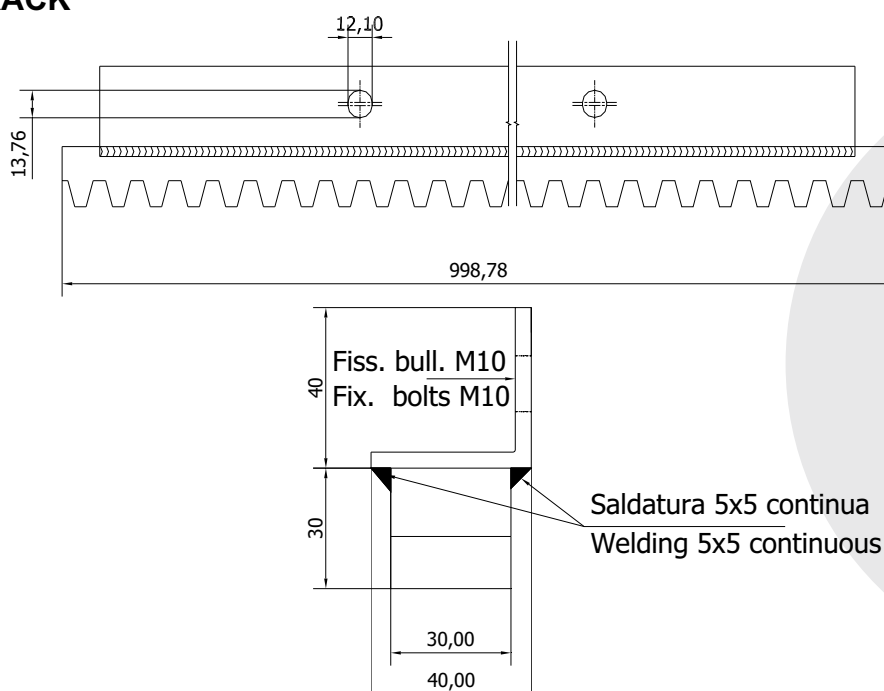

Fig. 4

The rack should preferably be welded to a 40x40 mm channel and then fastened to the gate with M10 bolts and nuts. Release the gearmotor and set the gate in the open position. Place the rack on pinion and move the gate manually to secure the rack along its full length. Once the rack has been secured, vertically adjust the geared motor so as to have a gap of 2 to 3 mm between the pinion and the rack with screws. Firmly secure the gearmotor with the nuts. Slightly lubricate the rack and pinion after assembly. Manually check that the gate slides evenly.

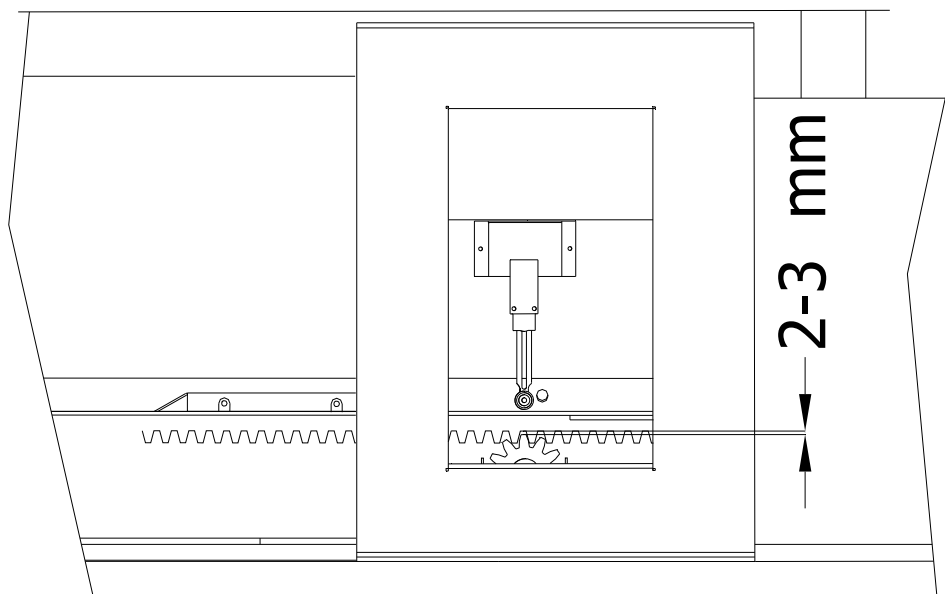

Fig. 5

POSITIONING THE LIMIT SWITCH CAMMES

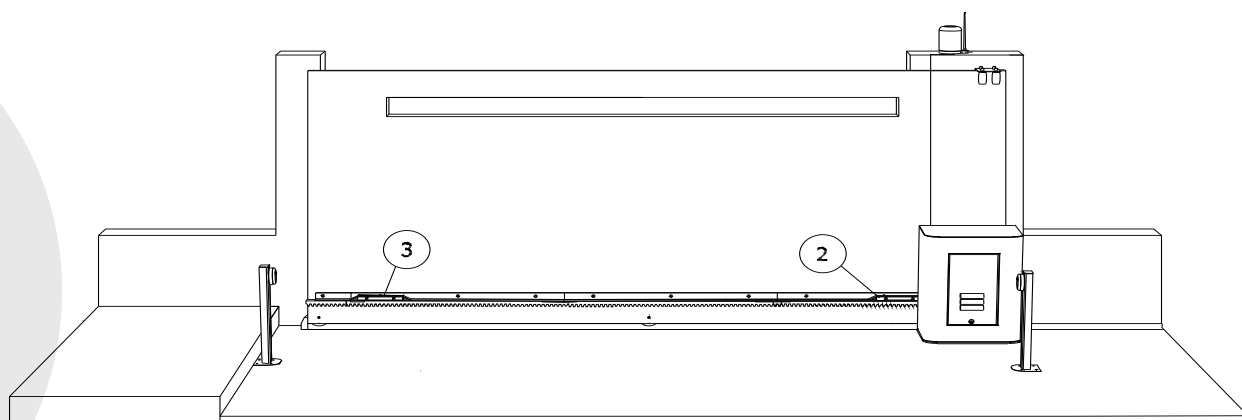

Fig. 6

Open the gate manually and fasten the limit switch cammes (2) (3) onto the rack.

USE OF MANUAL UNLOCKING

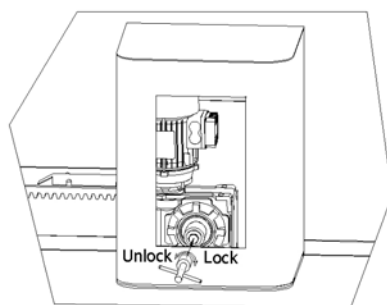

Fig.7

RELEASE INSTRUCTIONS

In case of fault or power failure, open the removable door and unlock the pinion gear by turning the pinion gear pin counter clockwise by means of a wrench. This allows moving the gate manually. Attention: perform locking and lock release operations with motor cut off.

LOCK INSTRUCTIONS

To lock the geared motor, rotate the pinion clockwise, strongly tighten, and re-close the removable door.

ADJUSTING THE CLUTCH

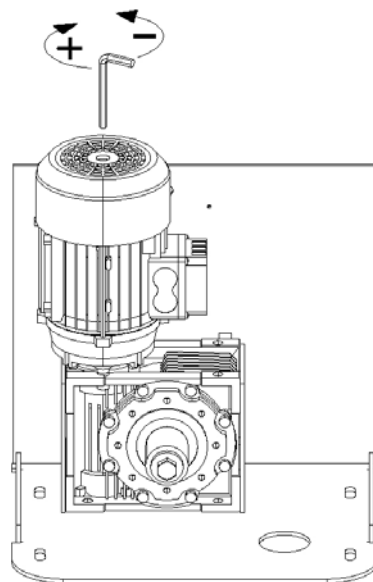

Fig. 8

Adjust the clutch as per fig.8.

◀ IF THE GEARMOTOR IS PROVIDED WITH THE QK-CE220RLINV CONTROL BOARD **THE CLUTCH CAN BE DISACTIVATED BY TIGHTENING THE BOLT COMPLETELY**

TYPICAL INSTALLATION

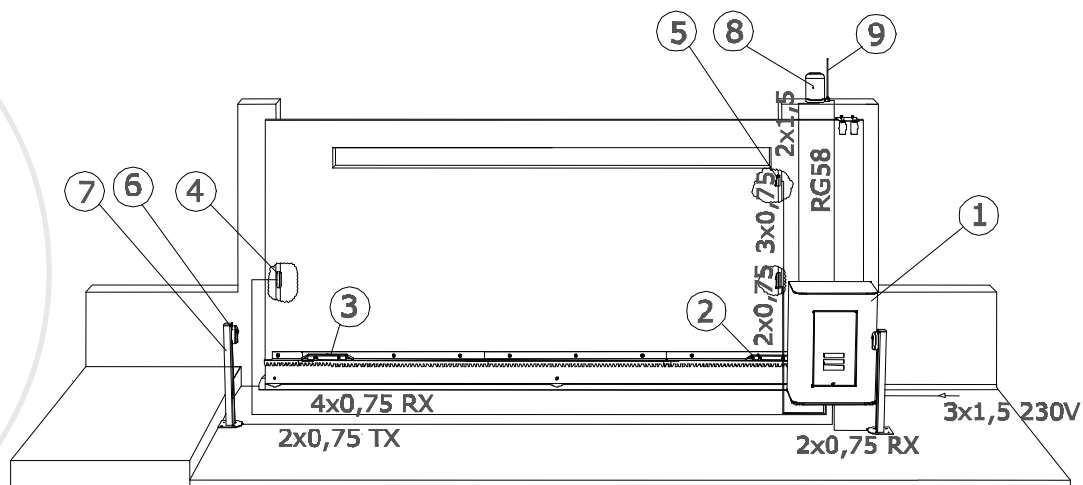

Fig. 9

MAIN COMPONENTS

- 1 - GEAR MOTOR
- 2 - CLOSING LIMIT SWITCH CAMME
- 3 - OPENING LIMIT SWITCH CAMME
- 4 - PHOTOCELL
- 5 - KEY SELECTOR
- 6 - PHOTOCELL ON POSTS
- 7 - PHOTOCELL POST
- 8 - FLASHING LAMP
- 9 - AERIAL

For all electrical connections see the Control Board INSTALLATION MANUAL

QK-CE220RLX CONTROL BOARD FOR SINGLE-PHASE / THREE-PHASE MOTORS

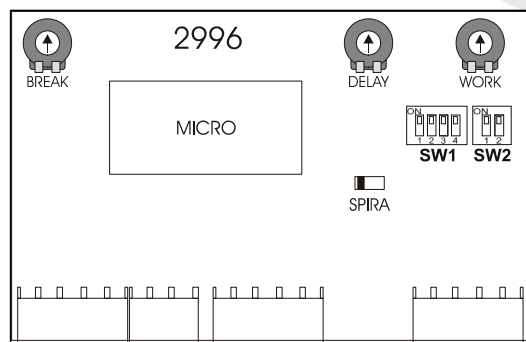
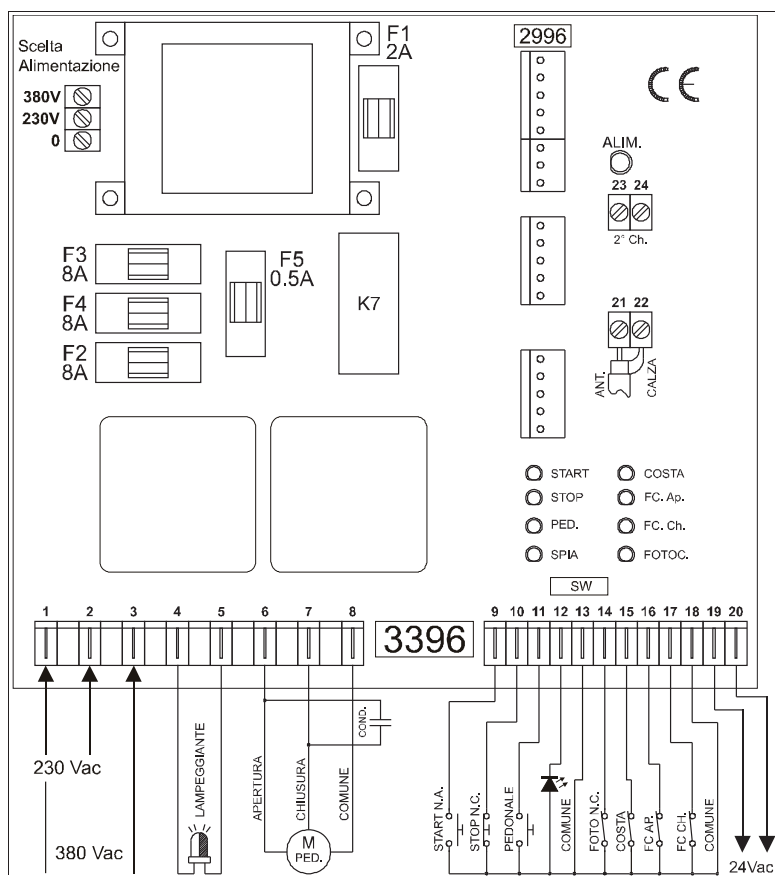

GENERAL ADVICE

QK-CE220RLX is a control board used for automation of heavy duty sliding gates. Suitable for a connection with a clock (timer) which can be connected to the start single input for timely controlled openings / closings. QK-CE220RLX control board is in compliance with the following directives: EMC 2004/108/EC, BT 2006/95/EC and RADIO SETS 1999/05/EC.

TECHNICAL FEATURES

Dimensions	260 x 210 x 100 mm IP55
Absorbed power	3W
24V fuse (F1)	2A
230V fuse (F2, F3, F4)	8A
Flashing lamp fuse (F5)	0,5A
Operating temperature	-30/+70°C
Motor relay contacts	16 A

ADVICES AND SUGGESTIONS FOR INSTALLATION

ATTENTION:

It is necessary to respect the polarity of the phases in the 230VAC connection (connector 1 = phase, connector 2 = neutral). The n. c. contacts (limit switches, photocells and stop push button) if not used, must be connected to the common (connector 13) using bridges.

CONNECTIONS TABLE

1 - 2 ALIMENT.	230 Vac 50Hz mains power supply (1 phase, 2 neutral)	12 - 13 SPIA	Opened gate lamp / courtesy lamp output (see dip switch).
1 - 2 - 3 ALIMENT.	380 Vac three-phase 50Hz mains power supply	14 - 18 FOTO	Photocell input (n.c. contact). It stops and reverses the motor and it is only enabled during closing.
4 - 5 FLASH	Flashing light output (fixed). 230 Vac max 100 W	15 - 18 COSTA	Safety edge input (n.c. contact) . It stops and reverses for 10cm the motor and it is only enabled during opening.
6 - 7 - 8 M	230/380 Vac 1 KW Max 1 HP motor output (7 close, 8 common, 6 open)	17 - 18 FC AP.	Opening limit switch input (n.c. contact).
9 - 13 START	Start signal (n.o. contact) . During opening it stops. During closing it stops and reverses. If "OPEN ONLY" function is enabled (see page 2) this contact will work as OPEN ONLY.	16 - 18 FC CH.	Closing limit switch input (n.c. contact)
10 - 13 STOP	Stop signal (n.c. contact). It always stops the motor. If pushed during pause it disables the automatic closing.	19 - 20 ALIMENT.	24 Vac 500mA accessories power supply
11 - 13 PED.	Pedestrian start signal (n.o. contact). It performs the partial opening adjustable by means of delay trimmer. If "CLOSE ONLY" function is enabled (see page 2) this contact will work as CLOSE ONLY.	21 - 22	Not used
380 230 0	Mains voltage selection: 230 Vac 0 - 230 380 Vac 0 - 380	23 - 24	Not used

FINAL TESTING

- ◆ **Check the connections of the motor bearing in mind that at first start up the motor should open.**

SETTING THE DIP-SWITCHES

ATTENTION: The dip switches should be programmed when the control board is switched off.

		ON	OFF
SW1	1	Slide gate mode	Not used
	2	Courtesy lamp mode enabled (90 seconds).	Opened gate lamp mode enabled.
	3	Condominium mode enabled. It doesn't accept start signals during opening. If a start signal is given during pause, the pause time gets reset and the gate closes.	Condominium mode disabled
	4	Automatic closing enabled.	Automatic closing disabled.
SW2	1	Not used	Not used
	2	Electric lock release function enabled	Electric lock release function disabled

WORKING TIME SETTING:

- 1) Make sure that the dip switch SW1 - 1 is on.
- 2) Adjust the WORK trimmer to modify the working time. It is possible to set it from 4" to 200".
- 3) **It is possible to use the pedestrian opening (partial opening), adjustable by means of DELAY trimmer (from 2" to 15").**

AUTOMATIC CLOSING TIME SETTING (PAUSE TIME):

- 1) Make sure that the dip switch SW1 - 4 is on.
- 2) Adjust the BREAK trimmer to modify the automatic closing pause time. It is possible to set it from 4" to 90".

OPEN ONLY AND CLOSE ONLY FUNCTION SETTING

Inserting a diode in the SPIRA connector, considering the polarity, it is possible to assign to the START button the OPEN ONLY function and to the PEDESTRIAN start button the close only function. Step-by-step function would then be disabled

RADIO RECEIVER CONNECTION

For the connection of the radio receiver refer to the user manual of the QK-R02.

EU Declaration of Conformity

and Declaration of Incorporation of "quasi-machines" (pursuant to the Machinery Directive 2006/42/CE, Att.II, B)

Company name:	QUIKO ITALY SRL
Postal address:	Via Seccalegno, 19
Postcode and City:	36040, Sossano (VI) - Italy
Telephone number:	+39 0444 785513
E-Mail address:	info@quikoitaly.com

declare that the DoC is issued under our sole responsibility and belongs to the following product:

Apparatus model/Product:	Titano: QK-T30004; QK-T40004; QK-T60004; QK-T10000INV;
Type:	AUTOMATIONS FOR SLIDING GATES (400V)
Batch:	See the label on the motor

The object of the declaration described above is in conformity with the relevant Union harmonisation legislation:

- **Directive 2006/42/CE (MD Directive)**
 - It is declared that the relevant technical documentation has been drawn-up in compliance with attachment VII B.
 - It is also declared that the following essential health and safety requirements have been respected: 1.1.1 - 1.1.2 - 1.1.3 - 1.1.5 - 1.2.1 - 1.2.6 - 1.3.1 - 1.3.2 - 1.3.3 - 1.3.4 - 1.3.7 - 1.3.9 - 1.5.1 - 1.5.2 - 1.5.4 - 1.5.5 - 1.5.6 - 1.5.7 - 1.5.8 - 1.5.10 - 1.5.11 - 1.5.13 - 1.6.1 - 1.6.2 - 1.6.4 - 1.7.2 - 1.7.3 - 1.7.4 - 1.7.4.1 - 1.7.4.2 - 1.7.4.3.
 - The undersigned declares that the afore-mentioned "partly-completed machinery" cannot be commissioned until the final machine, into which it has been incorporated, has been declared compliant with the Machinery Directive 2006/42/CE.
 - On duly justified request, the manufacturer commits to transmitting the information regarding the "partly-completed machinery" to the national authorities without prejudice to their intellectual property rights.
- **Directive 2014/53/EU (RED Directive)**
- **Directive 2011/65/EU (RoHS)**

The following harmonised standards and technical specifications have been applied:

Title:	Date of standard/specification
EN 61000-6-2	2005 + AC:2005
EN 61000-6-3	2007 + A1:2011+AC:2012,
EN 301 489-1 V2.2.3	2019
EN 301 489-3 V2.1.1	2017
EN 60335-2-103	2015
EN 12453	2017
EN 62479	2010
EN 300 220-2 V3.1.1	2017
EN IEC 63000	2018

Additional information

Signed for and on behalf of:		
Revision:	Place and date of issue:	Name, function, signature
01.00	GG/MM/AAAA	(Borinato Luca, Legal Officer)
	Sossano, 28/09/2021	

EU Declaration of Conformity for the Installer

Company name:

Postal address:

Postcode and City:

Telephone number:

E-Mail address:

declare that the DoC is issued under our sole responsibility and belongs to the following product:

Apparatus model/Product:

Type:

Installation location

The object of the declaration described above is in conformity with the relevant Union harmonisation legislation:

- Directive 2006/42/CE (MD Directive)
- Directive 2014/53/EU (RED Directive)
- Directive 2011/65/EU (RoHS)

The following harmonised standards and technical specifications have been applied:

Title:	Date of standard/specification
EN 61000-6-2	2005 + AC:2005
EN 61000-6-3	2007 + A1:2011+AC:2012,
EN 301 489-1 V2.2.3	2019
EN 301 489-3 V2.1.1	2017
EN ISO 12100	2010
EN 12453	2017
EN 12604	2017 +A1: 2020
EN 62479	2010
EN 300 220-2 V3.1.1	2017
EN IEC 63000	2018

Additional information

Signed for and on behalf of:

Revision:

01.00

Place and date of issue:

GG/MM/AAAA

Name, function, signature

(Administrator)

GENERAL ADVICE

Install a gate's safety system that complies with current regulations. Choose short routes for cables and keep power cables separate from control ones. Install the control card in a waterproof box. Please refer to current regulations when setting the gear motor's maximum torque. We advise you to install an outdoor switch, in compliance with European standards on the issue of safety, to turn the electricity off when servicing the gate. Check that each single installed device is efficient and effective. Affix easily readable signs warning about the presence of a motorised gate.

USE

It is absolutely forbidden to use the device for any other purposes. The installed electronic unit (which must have built-in electric friction), allows to select the following functions:

automatic: one control impulse will open or close the gate;
semi-automatic: one control impulse will open or close the gate.

In case of a blackout, manual operation is possible by activating the unlocking device. Having an automatic and electric power device requires special attention in a few situations:

- not to touch the device with wet hands and/or wet or bare feet;
- to turn off electricity before opening the control box and/or actuator;
- not to pull the lead to pull the plug out;
- to put the gate in movement only when it is completely visible;
- to keep out of the gate's range of action if it is moving. Wait until it has stopped;
- not to let children or animals play near the gate;
- not to let children use the remote control or other operating devices;
- to carry out routine maintenance;
- in case of failure, to turn off electricity and operate the gate manually only if it is possible and safe. Refrain from touching the gate and call an authorised technician.

MAINTENANCE

The TITANO SERIES geared motors are manufactured for long-term use. Nonetheless, their normal operation can be compromised by the conditions of the gate; therefore, we will list some operations to keep the gate efficient.

Warning: Non-specialized staff cannot operate the gate during maintenance. You are advised to cut the network power in order to avoid accidents or shocks. If the power must be on for various inspections, you are advised to check and/or deactivate any possible control devices (remote controls, keyboards, etc...) except for the device used by the maintenance operator.

Routine maintenance

Each of the following operations must be done when needed and in all cases at least every 6 months:

Gate

- Lubricate the gate's sliding wheels;
- Check the cleanliness and air-tightness of the rack.

Automation System

- Check the operation of the safety devices (photo-cells, ribs, torque limiter) using the methods described by the suppliers

Extraordinary Maintenance

If special maintenance is required for mechanical parts, you are advised to send the gear motor out for repairs to be performed by the technicians at the manufacturer.

14 horizontal lines for text entry.



QUIKO ITALY SRL

Via Seccalegno, 19
36040 Sossano (VI) - Italy
Tel. +39 0444 785513
Fax +39 0444 782371
info@quikoitaly.com
www.quikoitaly.com

