



USER MANUAL

NEO

SWING GATE OPENER / ATTUATORE PER CANCELLI A BATTENTE / MOTEUR POUR PORTAILS A BATTANT

TECHNICAL FEATURES	DATI TECNICI	DONNEES TECHNIQUES	QK-N400	QK-N400B
Power	Alimentazione	Alimentation	230Vac 50 / 60Hz	24Vdc
Current absorbed (motor) (A)	Assorbimento motore (A)	Intensità (A)	0,7-1,2	0,7 - 5
Power absorbed (W)	Potenza assorbita (W)	Puissance absorbée (W)	270	120
Capacitor (µF)	Condensatore (µF)	Condensateur (µF)	10	-
Protection level (IP)	Grado di protezione (IP)	Indice de protection (IP)	44	44
Opening time (sec)	Tempo apertura (sec)	Vitesse (sec)	18	18
Stroke (mm)	Corsa (mm)	Course (mm)	400	400
Max. thrust (N)	Spinta max. (N)	Couple max (N)	2000	2000
Working temp. (°C Min/Max)	Temp. di esercizio (°C Min/Max)	Temp. de service (°C Min/Max)	-30/+70	-30/+70
Thermal cut-out (°C)	Termoprotezione (°C)	Protection thermique (°C)	140	-
Working cycle (%)	Ciclo di lavoro (%)	Cycle de travail (%)	40	100
Motor weight (kg)	Peso motore (kg)	Poids (kg)	6	6
Max. leaf length (m)	Lunghezza max. anta (m)	Longueur maxi vantail (m)	4	4

	Installation limits per leaf Limiti di impiego per anta Contraintes d'utilisation				
	2m	2,5m	3m	3,5m	4m
QK-N400	700kg	500kg	400kg	350kg	300kg
QK-N400B	600kg	500kg	400kg	350kg	300kg

The values shown within the table above can be considerably reduced in windy areas.
I valori mostrati nella tabella sopra possono essere ridotti considerevolmente in zone ventose.
Les valeurs indiquées dans le tableau peuvent être considérablement réduites dans les zones venteuses.

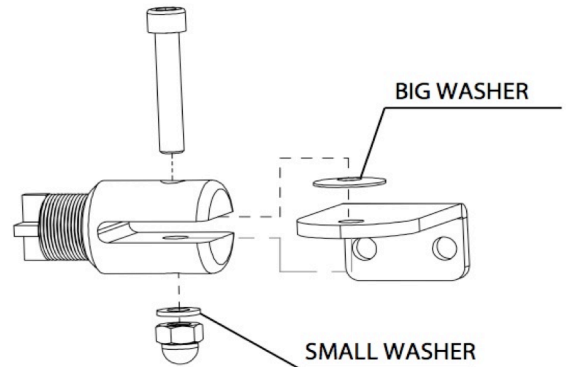

WIRING / CABLAGGIO / CABLAGE:

QK-N400:

BROWN CABLE – CAVO MARRONE – BRUNES CABLE
BLACK CABLE – CAVO NERO – NOIR CABLE
GREY CABLE – CAVO GRIGIO - GRIS CABLE
YELLOW/GREEN CABLE – CAVO GIALLO/VERDE - JAUNE/VERT CABLE

PHASE1 – FASE1
PHASE2 – FASE2
NEUTRAL – NEUTRO
GROUND - TERRA - MASSE

QK-N400B:

EACH ONE OF THE 2 CABLES CONTROL ONE SENSE OF ROTATION OF THE MOTOR
OGNUNO DEI 2 CAVI CONTROLLA UN SENSO DI ROTAZIONE DEL MOTORE
CHAQUE DES 2 CABLES COMMANDE UNE SENS DE ROTATION DU MOTEUR

MANUAL UNLOCKING / SBLOCCO MANUALE / DEBLOCAGE MANUEL:

In case of power blackout it is possible to open the gate manually unlocking the motor turning clockwise the apposite key.

In caso di mancanza di corrente è possibile aprire il cancello manualmente sbloccando il motore con la chiave girandola in senso orario.

En cas de blackout c'est possible d'ouvrir la porte utilisant déverrouillage manuel du moteur en tournant la clé dans le sens horaire.

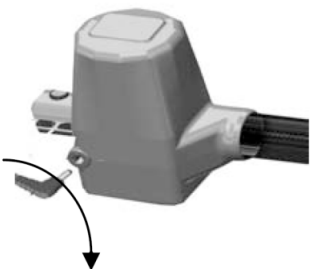

MEASURES TO BE RESPECTED / MISURE DA RISPETTARE / MESURES A RESPECTER:

QK-N400 / QK-N400B					
A (mm)	B (mm)		A (mm)	B (mm)	
	min	max		min	max
110	120	250	120	120	220
120	120	250	130	120	220
130	120	250	140	120	220
140	120	250	150	120	210
150	120	250	160	120	210
160	120	230	170	120	200
170	120	230	180	120	190
180	120	220	190	120	180
190	120	200	200	120	170
200	120	190	210	120	160
210	120	190	220	120	160
220	120	180	230	120	130
230	120	160	240	120	120
240	120	160	250	120	120
250	120	150			
260	120	140			
270	120	130			
280	120	120			

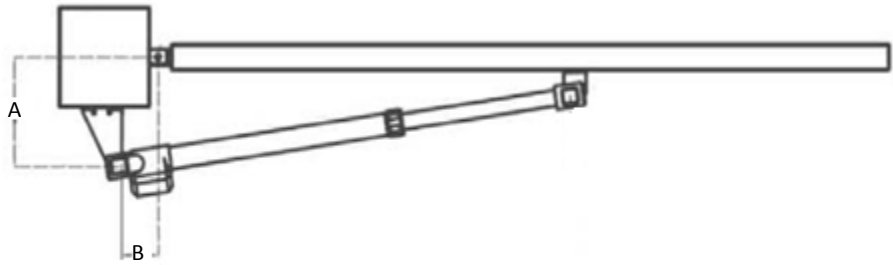

TYPICAL SYSTEM / INSTALLAZIONE TIPO / INSTALLATION TYPE:

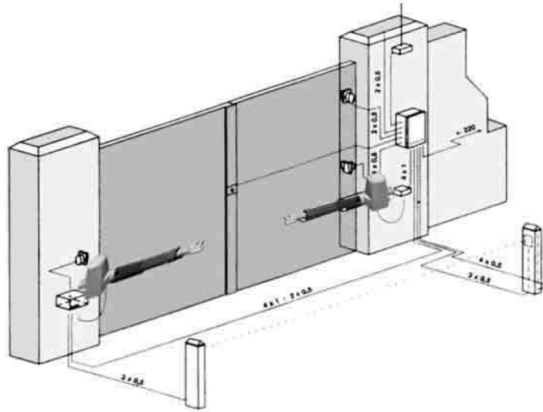

**DECLARATION OF CONFORMITY
(OF THE MANUFACTURER)**

Manufacturer: QUIKO ITALY SRL
Via Seccalegno, 19
36040 Sossano (VI)
Italia

hereby declares, under his liability, that products: QK-N400 and QK-N400B are in compliance with the essential safety requirements of the regulations:

- **Electro-magnetic Compatibility Directive2004/108/EC**
- **Low Voltage Directive2006/95/EC**
- **Machinery Directive2006/42/EC**

and their amendments and modifications, and with the regulations set forth by the National Legislative Body of the country in which the machinery is destined for use.

Sossano, 02/11/2011



Managing Director

Luca Borinato

www.quikoitaly.com