

NEO USER MANUAL V04

SWING GATE OPENER
ATTUATORE PER CANCELLI A BATTENTE
MOTEUR POUR PORTAILS A BATTANT



TECHNICAL FEATURES	DATI TECNICI	DONNEES TECHNIQUES	QK-N400
Power	Alimentazione	Alimentation	230Vac 50 / 60Hz
Current absorbed (motor) (A)	Assorbimento motore (A)	Intensité (A)	0,9-1,5
Power absorbed (W)	Potenza assorbita (W)	Puissance absorbée (W)	350
Capacitor (µF)	Condensatore (µF)	Condensateur (µF)	8
Protection level (IP)	Grado di protezione (IP)	Indice de protection (IP)	44
Opening time (sec)	Tempo apertura (sec)	Vitesse (sec)	20
Stroke (mm)	Corsa (mm)	Course (mm)	400
Max. thrust (N)	Spinta max. (N)	Couple max (N)	2200
Working temp. (°C Min/Max)	Temp. di esercizio (°C Min/Max)	Temp. de service (°C Min/Max)	-30/+70
Thermal cut-out (°C)	Termoprotezione (°C)	Protection thermique (°C)	150
Working cycle (%)	Ciclo di lavoro (%)	Cycle de travail (%)	40
Motor weight (kg)	Peso motore (kg)	Poids (kg)	6
Max. leaf length (m)	Lunghezza max. anta (m)	Longueur maxi vantail (m)	4

WIRING / CABLAGGIO / CABLAGE:

BROWN CABLE – CAVO MARRONE – BRUNES CABLE: PHASE1 - FASE1 - PHASE1
BLACK CABLE – CAVO NERO – NOIR CABLE: PHASE2 - FASE2 - PHASE2
GREY CABLE – CAVO GRIGIO - GRIS CABLE: NEUTRAL - NEUTRO - NEUTRE
YELLOW/GREEN CABLE – CAVO GIALLO/VERDE - JAUNE/VERT CABLE: GROUND - TERRA - MASSE

Installation limits per leaf Limiti d'impiego per anta Contraintes d'utilisation					
	2m	2,5m	3m	3,5m	4m
QK-N400	700kg	500kg	400kg	350kg	300kg

The values shown within the table above can be considerably reduced in windy areas.
I valori mostrati nella tabella sopra possono essere ridotti considerevolmente in zone ventose.
Les valeurs indiquées dans le tableau peuvent être considérablement réduits dans les zones venteuses.

MANUAL UNLOCKING / SBLOCCO MANUALE / DEBLOCAGE MANUEL:

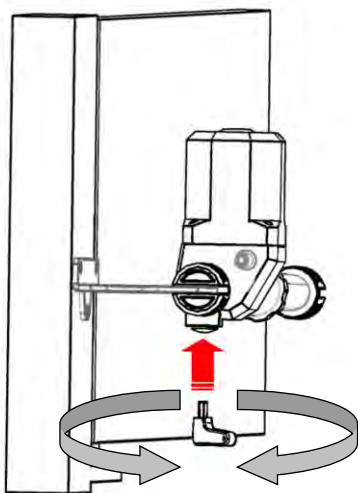

To manually unlock and re-lock the actuator, act with the supplied key on the release screw.
1 - Remove the protection cover and insert the key into the seat allocation as shown in the figure on the left;
2 - Turn the key to unlock the actuator and in the opposite way to re-lock the actuator.

Per sbloccare e bloccare manualmente l'attuatore, agire con la chiave in dotazione sulla vite di sblocco.

1 - Rimuovere il coperchio di protezione ed inserire la chiave in dotazione nella sede come mostrato nella figura a sinistra;
2 - Ruotare la chiave nel senso indicato sulla freccia per sbloccare l'attuatore ed in senso opposto per bloccarlo.

Pour déverrouiller et re-verrouiller manuellement l'actionneur, agir avec la clé fournie sur la vis de déverrouillage.

1 - Ôter je bouche de protection et insérer la clé en dotation dans le siège comme en figure;
2 - Tourner la clé pour déverrouiller l'actionneur et dans le sens inverse pour reverrouiller l'actionneur.

MEASURES TO BE RESPECTED / MISURE DA RISPETTARE / MESURES A RESPECTER:

MIN / MAX A AND B MEASURES					
$\alpha = 90^\circ$			$\alpha = 100^\circ$		
A (mm)	B (mm)		A (mm)	B (mm)	
	min	max		min	max
110	120	250	120	120	220
120	120	250	130	120	220
130	120	250	140	120	220
140	120	250	150	120	210
150	120	250	160	120	210
160	120	230	170	120	200
170	120	230	180	120	190
180	120	220	190	120	180
190	120	200	200	120	170
200	120	190	210	120	160
210	120	190	220	120	160
220	120	180	230	120	130
230	120	160	240	120	120
240	120	160	250	120	120
250	120	150			

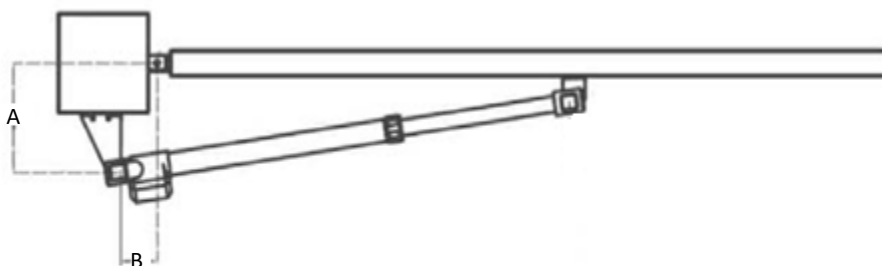

**MAX. DISTANCE
BETWEEN BRACKETS**

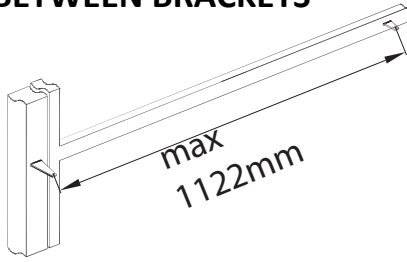

PUSH TO OPEN SOLUTION

If necessary, when PUSH TO OPEN installation is required, extending the bracket on the pillar, it is possible to install the motor internally and let the gate open externally as per the image on the right:

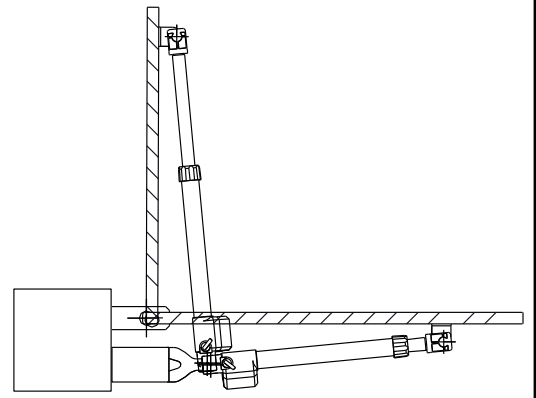

EU Declaration of Conformity

and Declaration of Incorporation of "quasi-machines" (pursuant to the Machinery Directive 2006/42/CE, Att.II, B)



Company name:	QUIKO ITALY SRL
Postal address:	Via Seccalegno, 19
Postcode and City:	36040, Sossano (VI) - Italy
Telephone number:	+39 0444 785513
E-Mail address:	info@quikoitaly.com

declare that the DoC is issued under our sole responsibility and belongs to the following product:

Apparatus model/Product:	Neo: QK-N400
Type:	AUTOMATIONS FOR SWING GATES (230/110/24V)
Batch:	See the label on the motor

The object of the declaration described above is in conformity with the relevant Union harmonisation legislation:

- **Directive 2006/42/CE (MD Directive)**
 - It is declared that the relevant technical documentation has been drawn-up in compliance with attachment VII B.
 - It is also declared that the following essential health and safety requirements have been respected: 1.1.1 - 1.1.2 - 1.1.3 - 1.1.5 - 1.2.1 - 1.2.6 - 1.3.1 - 1.3.2 - 1.3.3 - 1.3.4 - 1.3.7 - 1.3.9 - 1.5.1 - 1.5.2 - 1.5.4 - 1.5.5 - 1.5.6 - 1.5.7 - 1.5.8 - 1.5.10 - 1.5.11 - 1.5.13 - 1.6.1 - 1.6.2 - 1.6.4 - 1.7.2 - 1.7.3 - 1.7.4 - 1.7.4.1 - 1.7.4.2 - 1.7.4.3.
 - The undersigned declares that the afore-mentioned "partly-completed machinery" cannot be commissioned until the final machine, into which it has been incorporated, has been declared compliant with the Machinery Directive 2006/42/CE.
 - On duly justified request, the manufacturer commits to transmitting the information regarding the "partly-completed machinery" to the national authorities without prejudice to their intellectual property rights.

- **Directive 2014/53/EU (RED Directive)**
- **Directive 2011/65/EU (RoHS)**

The following harmonised standards and technical specifications have been applied:

Title:	Date of standard/specification
EN 61000-6-2	2005 + AC:2005
EN 61000-6-3	2007 + A1:2011+AC:2012,
EN 301 489-1 V2.2.3	2019
EN 301 489-3 V2.1.1	2017
EN 60335-2-103	2015
EN 12453	2017
EN 62479	2010
EN 300 220-2 V3.1.1	2017
EN IEC 63000	2018

Signed for and on behalf of:

Revision:	Place and date of issue:	Name, function, signature
01.00	Sossano, 28/09/2021	(Borinato Luca, Legal Officer)

