

USER MANUAL

EON 600

V03

SWING GATE OPENER
ATTUATORE PER CANCELLI A BATTENTE
MOTEUR POUR PORTAILS A BATTANT



MADE IN ITALY

TECHNICAL FEATURES	DATI TECNICI	DONNEES TECHNIQUES	QK-E600 QK-E600FX
Power	Alimentazione	Alimentation	230Vac 50 / 60Hz
Current absorbed (motor) (A)	Assorbimento motore (A)	Intensité (A)	0,9-1,5
Power absorbed (W)	Potenza assorbita (W)	Puissance absorbée (W)	350
Capacitor (µF)	Condensatore (µF)	Condensateur (µF)	8
Protection level (IP)	Grado di protezione (IP)	Indice de protection (IP)	44
Opening time (sec)	Tempo apertura (sec)	Vitesse (sec)	20 10
Stroke (mm)	Corsa (mm)	Course (mm)	600
Max. thrust (N)	Spinta max. (N)	Couple max (N)	2200
Working temp. (°C Min/Max)	Temp. di esercizio (°C Min/Max)	Temp. de service (°C Min/Max)	-30/+70
Thermal cut-out (°C)	Termoprotezione (°C)	Protection thermique (°C)	150
Working cycle (%)	Ciclo di lavoro (%)	Cycle de travail (%)	40
Motor weight (kg)	Peso motore (kg)	Poids (kg)	6
Max. leaf length (m)	Lunghezza max. anta (m)	Longueur maxi vantail (m)	5

WIRING / CABLAGGIO / CABLAGE:

QK-E600

BROWN CABLE – CAVO MARRONE – BRUNES CABLE
 BLACK CABLE – CAVO NERO – NOIR CABLE
 GREY CABLE – CAVO GRIGIO - GRIS CABLE
 YELLOW/GREEN CABLE – CAVO GIALLO/VERDE - JAUNE/VERT CABLE

PHASE1 – FASE1
 PHASE2 – FASE2
 NEUTRAL – NEUTRO
 GROUND - TERRA - MASSE



MANUAL UNLOCKING / SBLOCCO MANUALE / DEBLOCAGE MANUEL:



In case of power blackout it is possible to open the gate manually unlocking the motor turning counterclockwise the apposite key.

In caso di mancanza di corrente è possibile aprire il cancello manualmente sbloccando il motore con la chiave girandola in senso antiorario.

En cas de blackout c'est possible d'ouvrir la porte utilisant déverrouillage manuel du moteur en tournant la clé dans le sens antihoraire.

MEASURES TO BE RESPECTED / MISURE DA RISPETTARE / MESURES A RESPECTER:

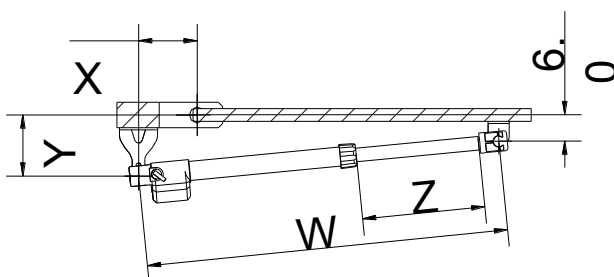

QK-E600	ROTATION 95 °			
	W	X	Y	Z
	1532	280	280	678
QK-E600	ROTATION 120 °			
	W	X	Y	Z
	1532	310	120	678

PUSH TO OPEN SOLUTION

If necessary, when PUSH TO OPEN installation is required, extending the bracket on the pillar, it is possible to install the motor internally and let the gate open externally as per the image below:

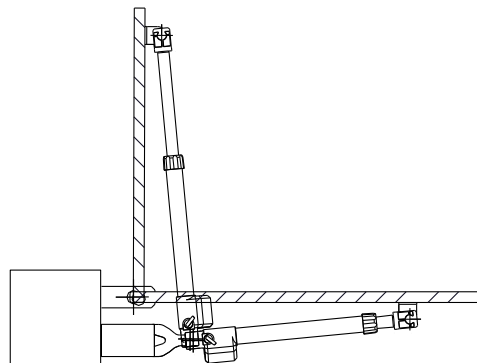

EU Declaration of Conformity

and Declaration of Incorporation of "quasi-machines" (pursuant to the Machinery Directive 2006/42/CE, Att.II, B)



Company name:	QUIKO ITALY SRL
Postal address:	Via Seccalegno, 19
Postcode and City:	36040, Sossano (VI) - Italy
Telephone number:	+39 0444 785513
E-Mail address:	info@quikoitaly.com

declare that the DoC is issued under our sole responsibility and belongs to the following product:

Apparatus model/Product:	Eon: QK-E400 ; QK-E400FX ; QK-E400B ; QK-E400BFX ; QK-E600 ; QK-E600FX
Type:	AUTOMATIONS FOR SWING GATES (230/110/24V)
Batch:	See the label on the motor

The object of the declaration described above is in conformity with the relevant Union harmonisation legislation:

- **Directive 2006/42/CE (MD Directive)**
 - It is declared that the relevant technical documentation has been drawn-up in compliance with attachment VII B.
 - It is also declared that the following essential health and safety requirements have been respected: 1.1.1 - 1.1.2 - 1.1.3 - 1.1.5 - 1.2.1 - 1.2.6 - 1.3.1 - 1.3.2 - 1.3.3 - 1.3.4 - 1.3.7 - 1.3.9 - 1.5.1 - 1.5.2 - 1.5.4 - 1.5.5 - 1.5.6 - 1.5.7 - 1.5.8 - 1.5.10 - 1.5.11 - 1.5.13 - 1.6.1 - 1.6.2 - 1.6.4 - 1.7.2 - 1.7.3 - 1.7.4 - 1.7.4.1 - 1.7.4.2 - 1.7.4.3.
 - The undersigned declares that the afore-mentioned "partly-completed machinery" cannot be commissioned until the final machine, into which it has been incorporated, has been declared compliant with the Machinery Directive 2006/42/CE.
 - On duly justified request, the manufacturer commits to transmitting the information regarding the "partly-completed machinery" to the national authorities without prejudice to their intellectual property rights.

- **Directive 2014/53/EU (RED Directive)**
- **Directive 2011/65/EU (RoHS)**

The following harmonised standards and technical specifications have been applied:

Title:	Date of standard/specification
EN 61000-6-2	2005 + AC:2005
EN 61000-6-3	2007 + A1:2011+AC:2012,
EN 301 489-1 V2.2.3	2019
EN 301 489-3 V2.1.1	2017
EN 60335-2-103	2015
EN 12453	2017
EN 62479	2010
EN 300 220-2 V3.1.1	2017
EN IEC 63000	2018

Additional information

Signed for and on behalf of:		
Revision:	Place and date of issue:	Name, function, signature
01.00	Sossano, 28/09/2021	(Borinato Luca, Legal Officer)