



use and maintenance manual

SUB

NEW 2016 MODEL

UNDERGROUND GEARMOTOR FOR SWING GATES

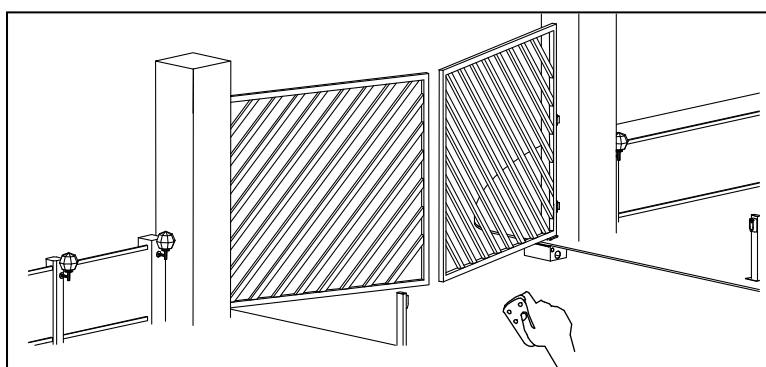
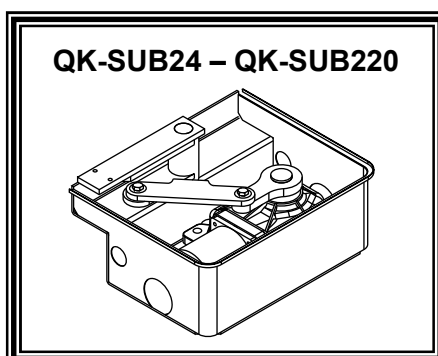

qui»lö[®]
opening solutions

Canalizzazione elettrica
Trunking

Alcantarilla para cables electricos
Egout de cables electricos

Drenaggio acqua
Drainage water
Drenaje de agua
Aqua vidange

Centro scatola
Center box
Centro de la caja
Centre box

A

B

C

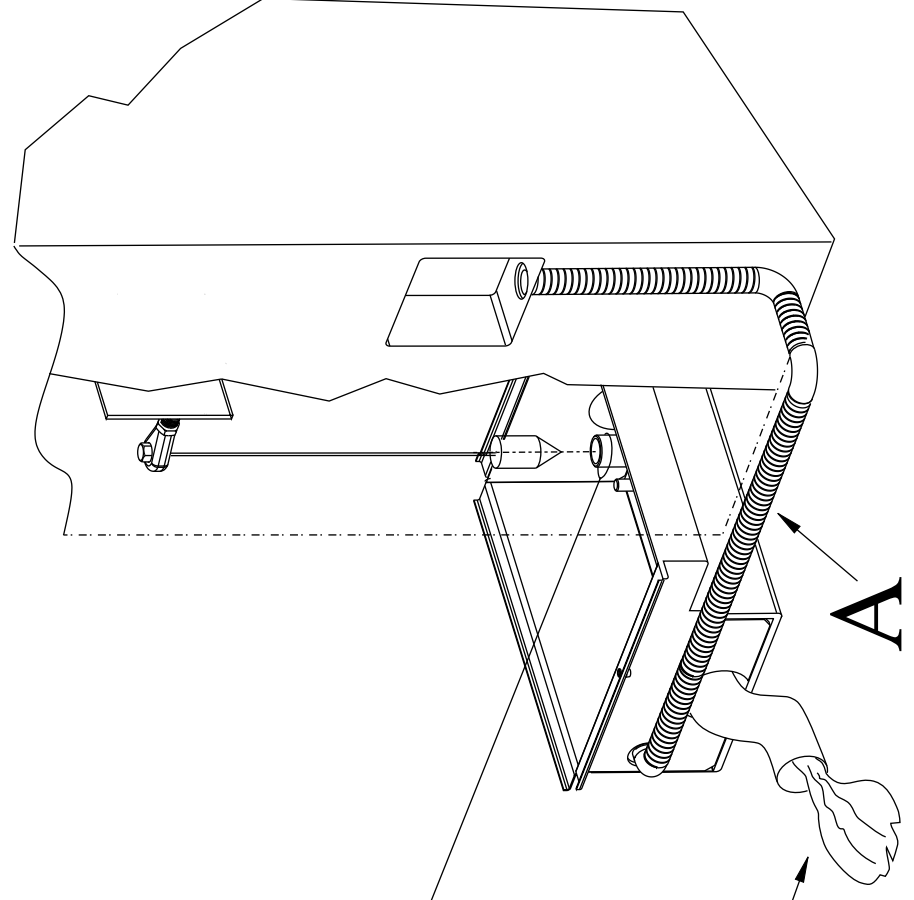
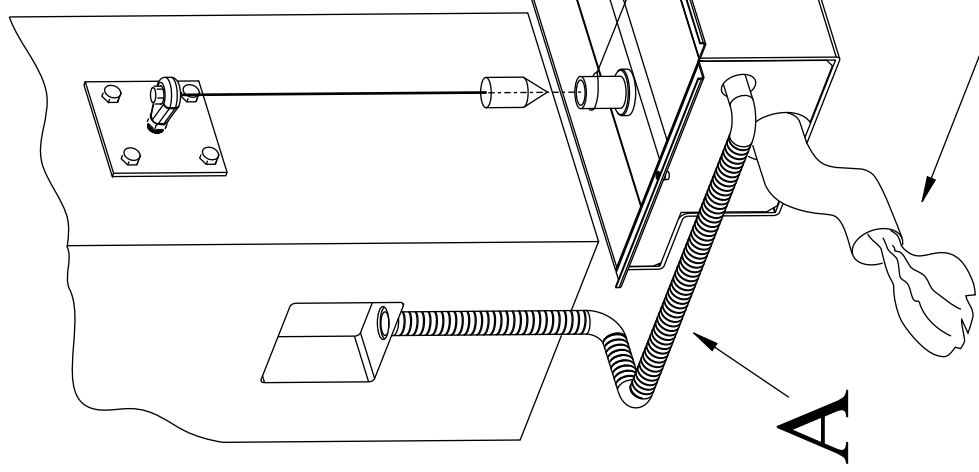

INDEX

Pag.

TYPICAL INSTALLATION.....	3
TECHNICAL DATA.....	3
DIMENSIONS	4
TYPICAL CONNECTION AND CABLE SECTION.....	4
CONSIDERATIONS FOR INSTALLATION.....	5
INSTALLATION.....	5-6-7-8-9
TROUBLESHOOTING.....	10
GENERAL ADVICE, USE AND MAINTENANCE.....	11
DECLARATION OF CONFORMITY (MANUFACTURER).....	12
DECLARATION OF CONFORMITY (INSTALLER).....	13

TYPICAL INSTALLATION

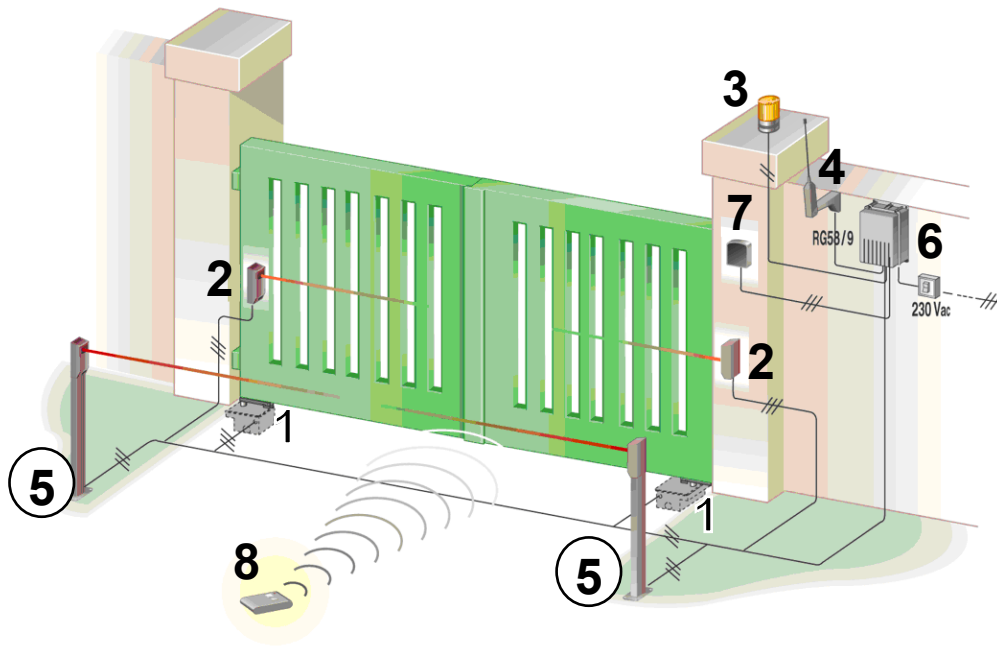

- 1- Operator
- 2- External photocell
- 3- Flashing warning light
- 4- Antenna
- 5- Internal photocell
- 6- Electronic control unit
- 7- Key-switch
- 8- Remote control

INSTALLATION LIMITS

	2m	2,5m	3m	3,5m
QK-SUB220	800kg	600kg	500kg	400kg
QK-SUB24	700kg	500kg	400kg	300kg

The values shown within table above can be reduced considerably in windy areas

TECHNICAL DATA	24V	230V
	Max. weight of leaf	See installation limits table
Max. width of leaf	3,50 mt	
Motors power supply	24 Vdc	230 Vac
Motor power	50 W	280 W
Motor RPM	1800	1400
Capacitor	/	12,5 µF
Max. Thrust	300N	380N
Working temperature	-30° C / +70° C	
Motor weight	10 Kg	
Protection rating	IP 67	
Opening time 90°	16 sec	
Working cycle (%)	100	50
Current absorbed (motor)	3 A	1.4 A

DIMENSIONS

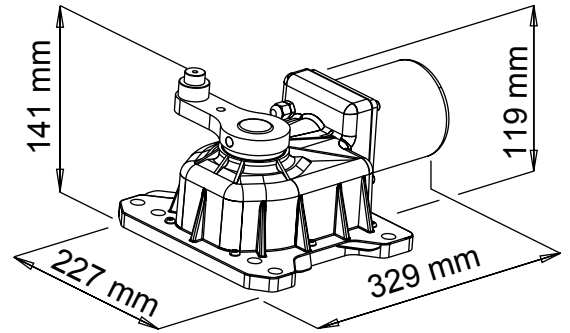
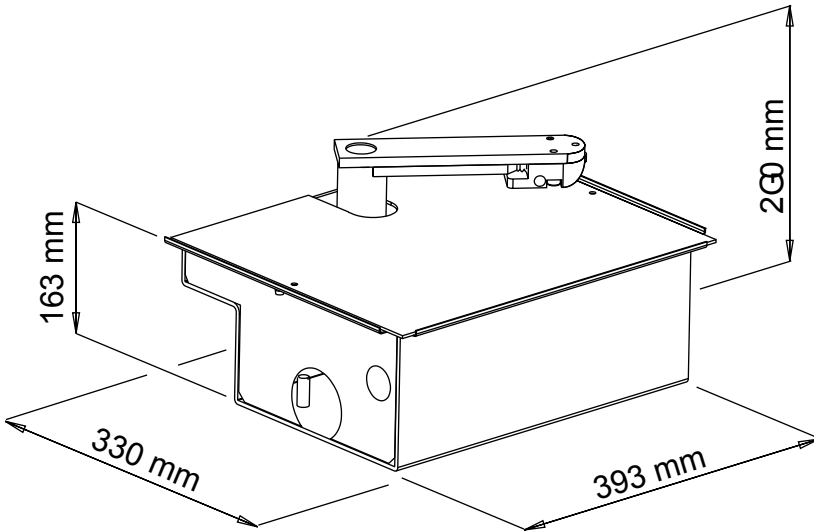

TYPICAL CONNECTION AND CABLE SECTION

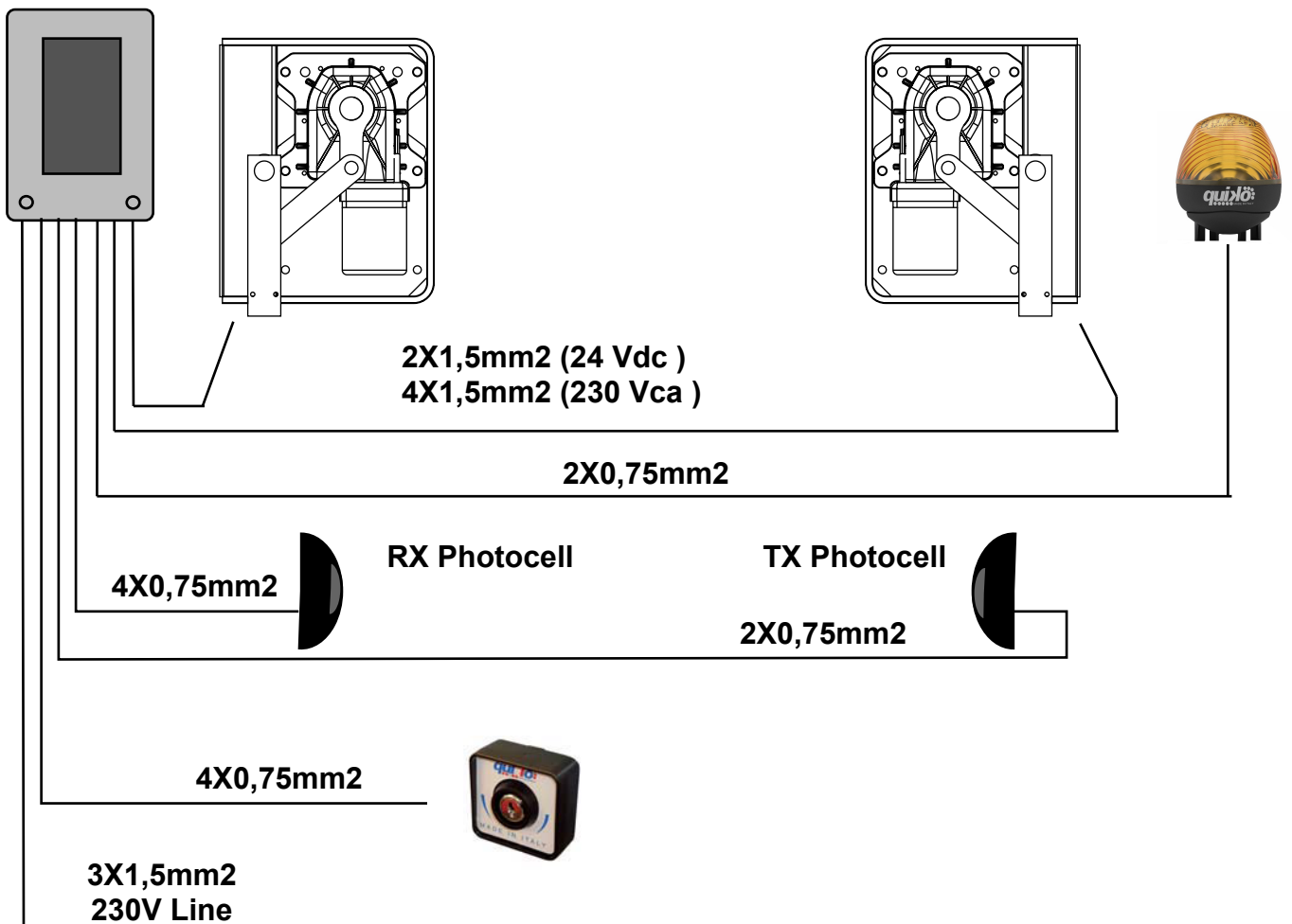

CONSIDERATIONS FOR INSTALLATION

- The installation and testing operations must be performed solely by qualified personnel in order to guarantee the proper and safe operation of the automatic gate.
- The company declines any responsibility for damage caused by incorrect installations due to incompetence and/or negligence.
- Before assembling the automatism, check that the gate is in perfect working order, hangs well on its hinges and is suitably lubricated. It must also comply with the safety standards in force in the country of installation..

INSTALLATION

Introductory note: Dig a hole big enough to hold the foundation box, calculate the required opening angle, insert the sheath for laying the power cable, make water drainage holes in the ground and cement the box solidly.

GATE WING OPENING ANGLE

Establish the required opening angle

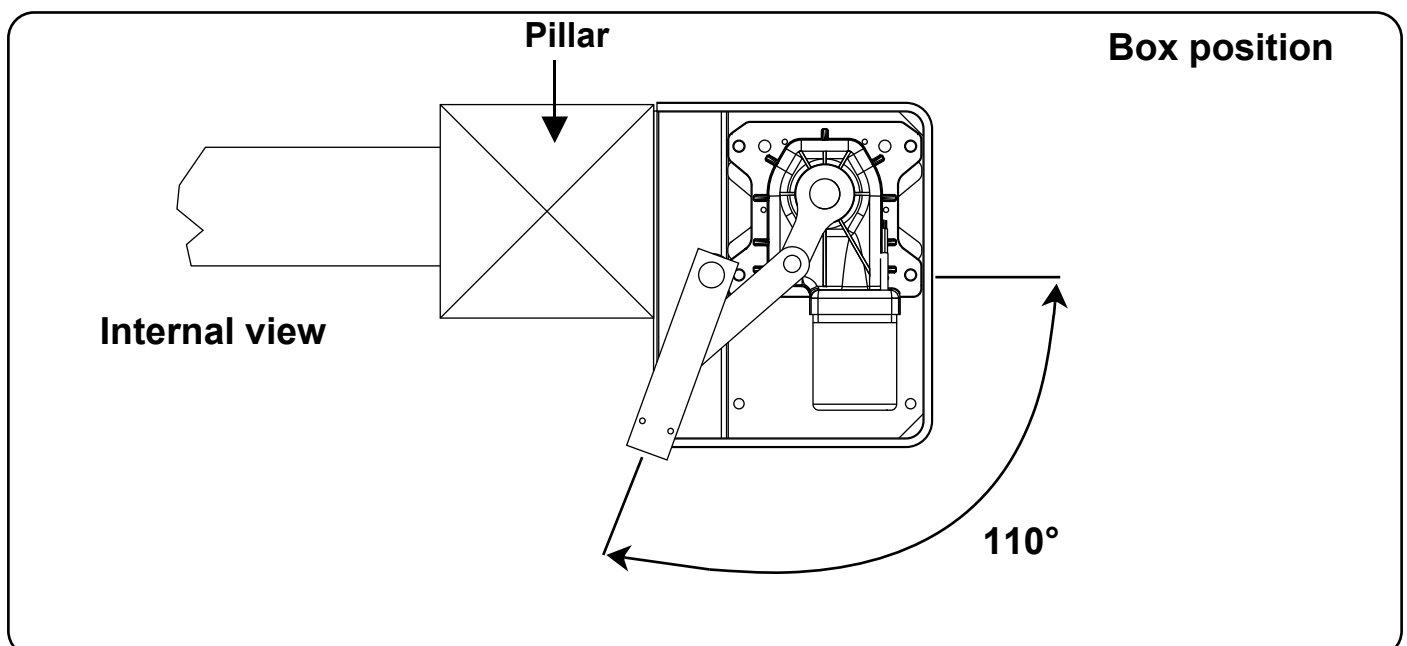
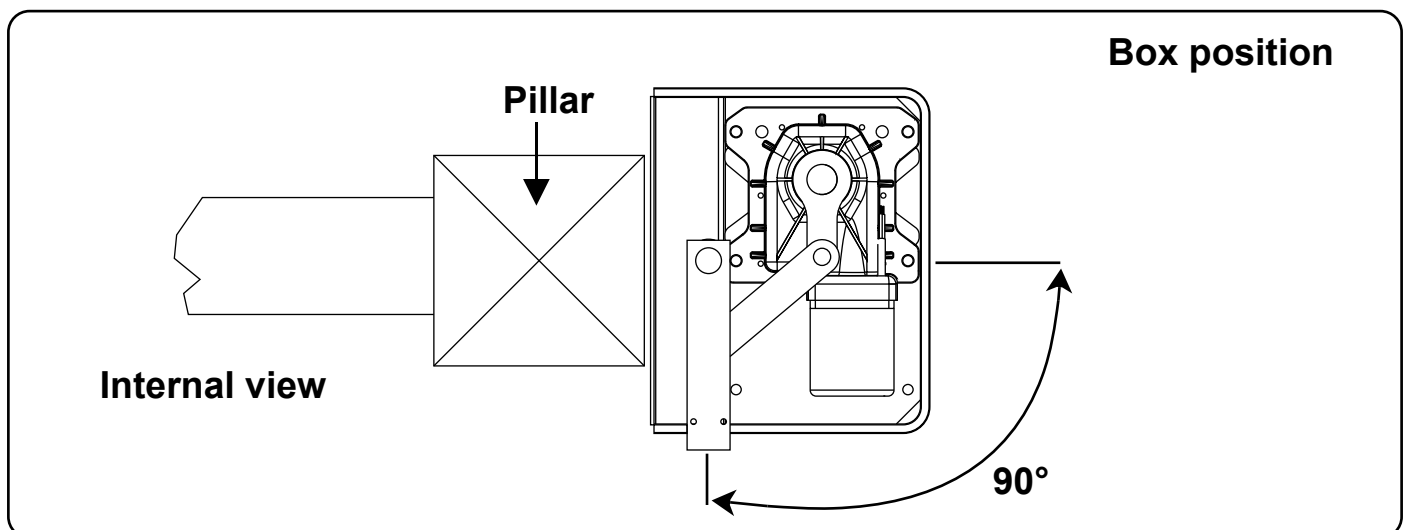

BOX INSTALLATION PROCEDURE

Dig a hole big enough to hold the box containing the operator **(C1)**

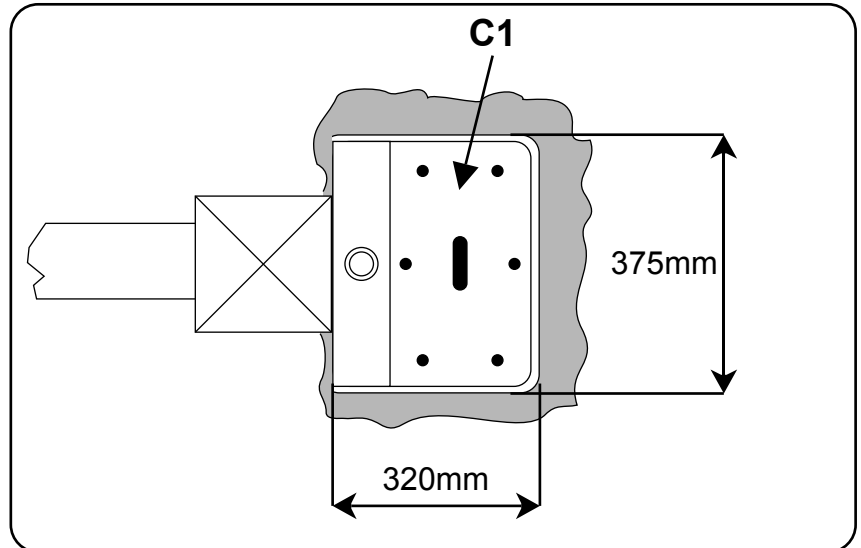

Insert the tube for water drainage in the prepared hole **(F1)**

Insert the sheath for laying the power cables **(F2)**.

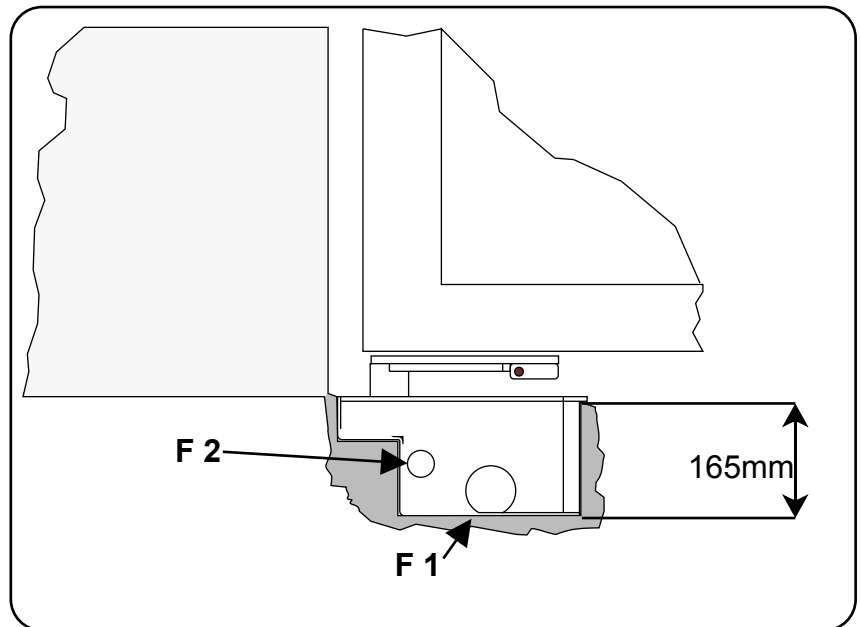

Note: while positioning the box, keep in mind the minimum distance there must be between the pillar and the centre of rotation of the gate hinge.

Cement so that the box cannot be moved, wait for it to dry and then assemble the operator and levers.

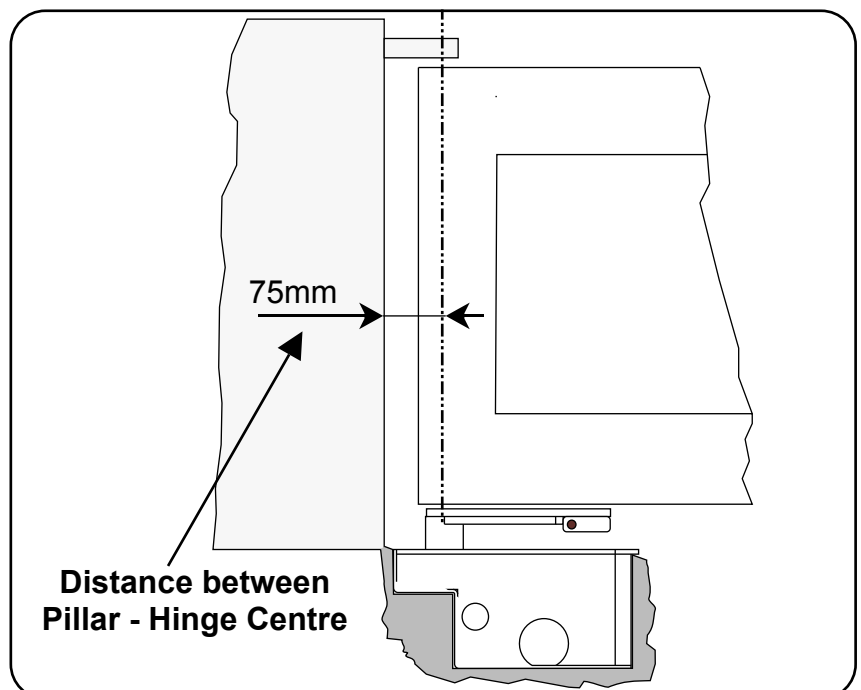

ASSEMBLING THE OPERATOR AND LEVERS

Insert the motor into the foundation case and fix it with nuts and washers supplied

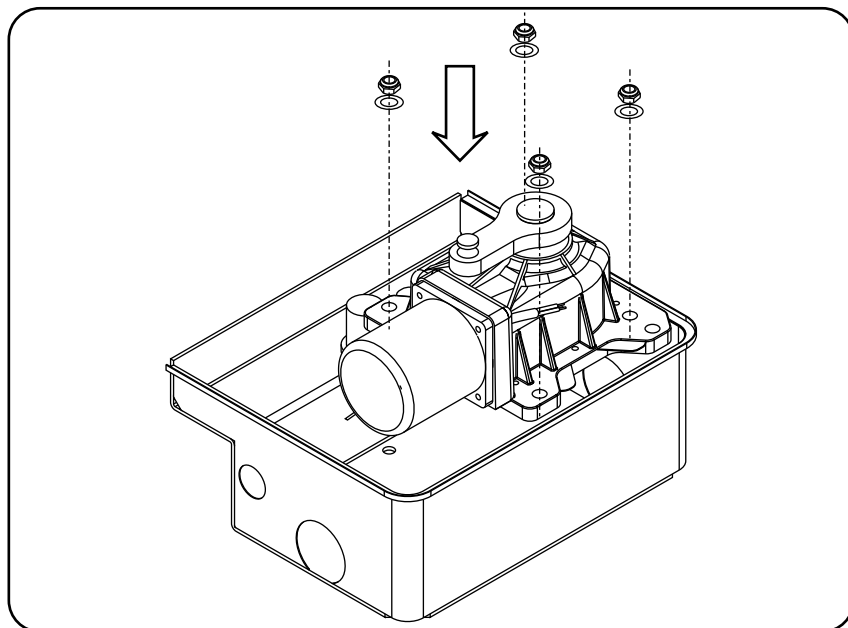

Insert the ball in the pin located on the box and fit the gate anchorage lever (L1)

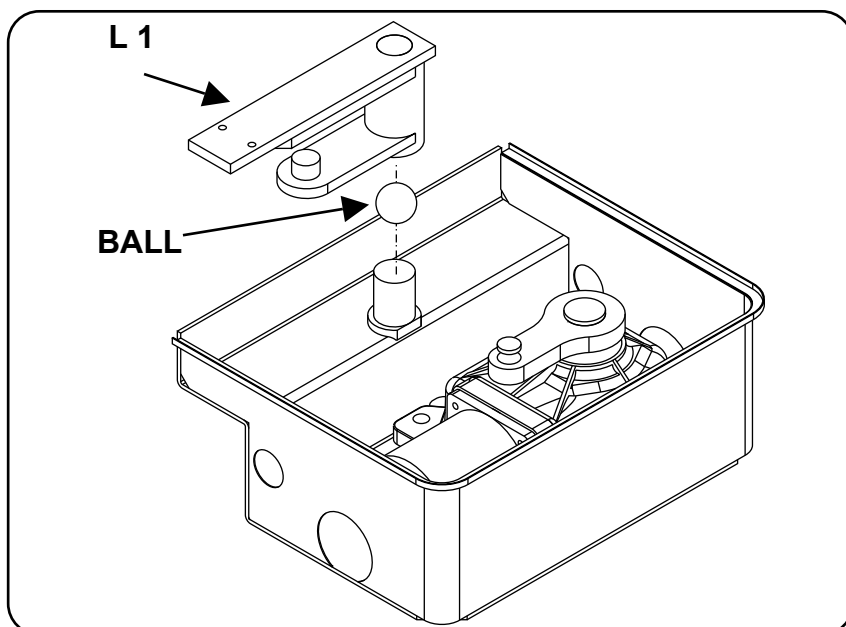

Put the connection lever (L2) between the levers (L3) and (L4) and block it with screws and washers supplied

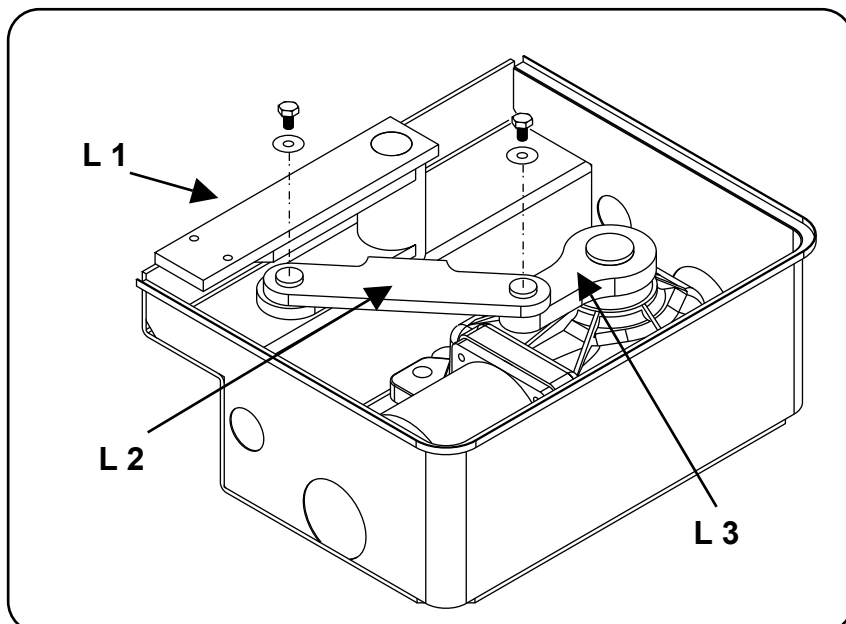

FASTENING THE OPERATOR LEVER TO THE GATE

Insert the cover and fasten it with the screws provided

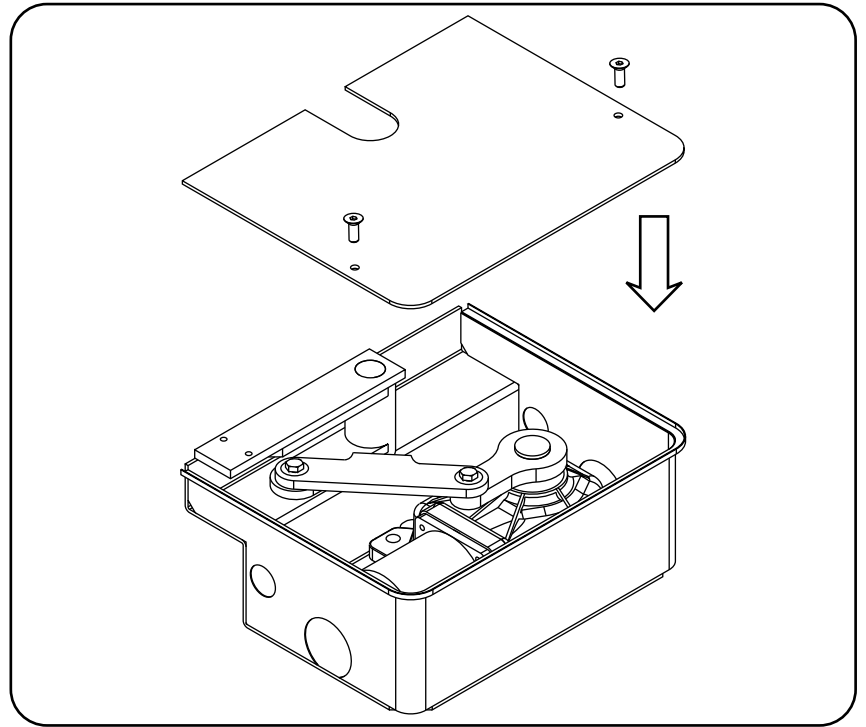

Position the gate wing and the lever (**L1**) so that they are perfectly aligned and fasten them by welding or similar.

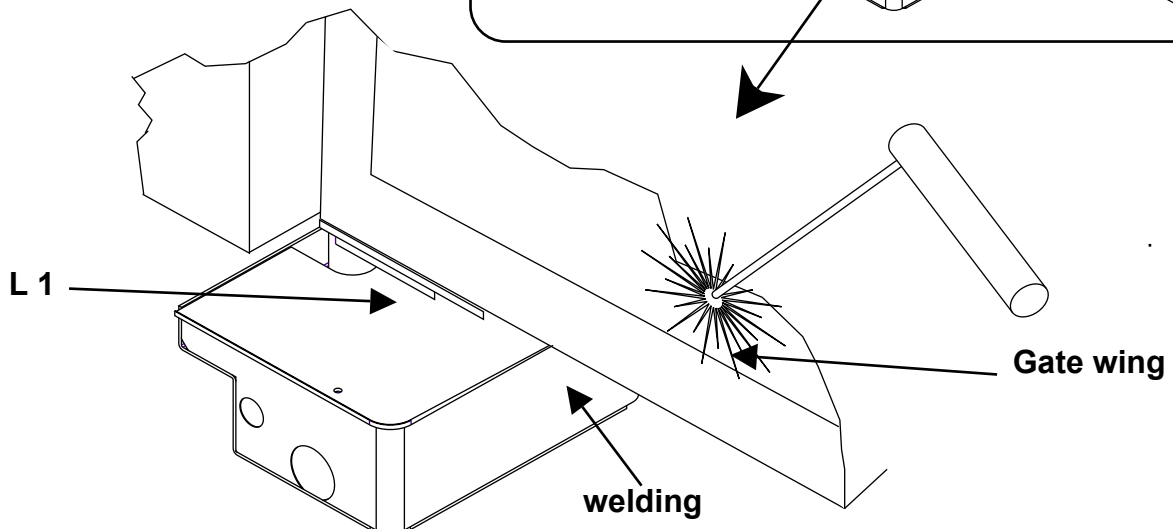
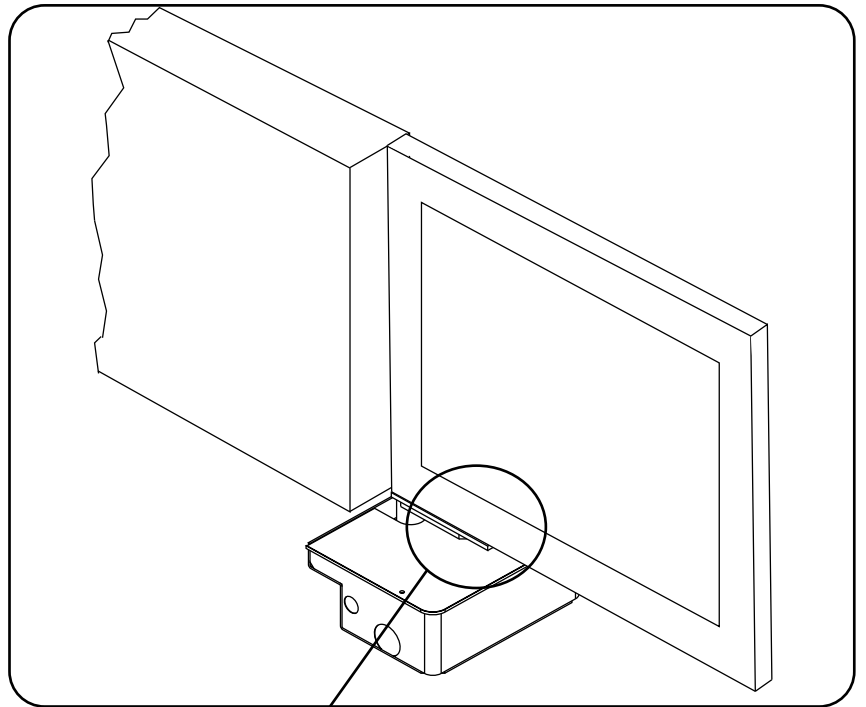

EMERGENCY RELEASE PROCEDURE

Insert the key **C** provided into the appropriate hole on the lever **L1**

Turn the key

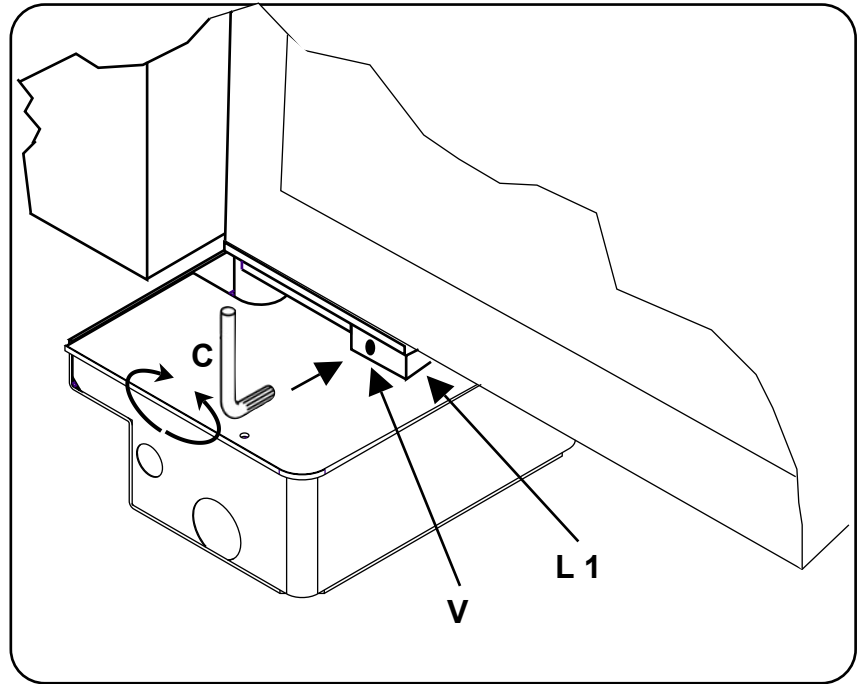

LIMIT SWITCHES ASSEMBLY (OPTIONAL)

Insert, regulate and block the mechanical limit switches in the desired position

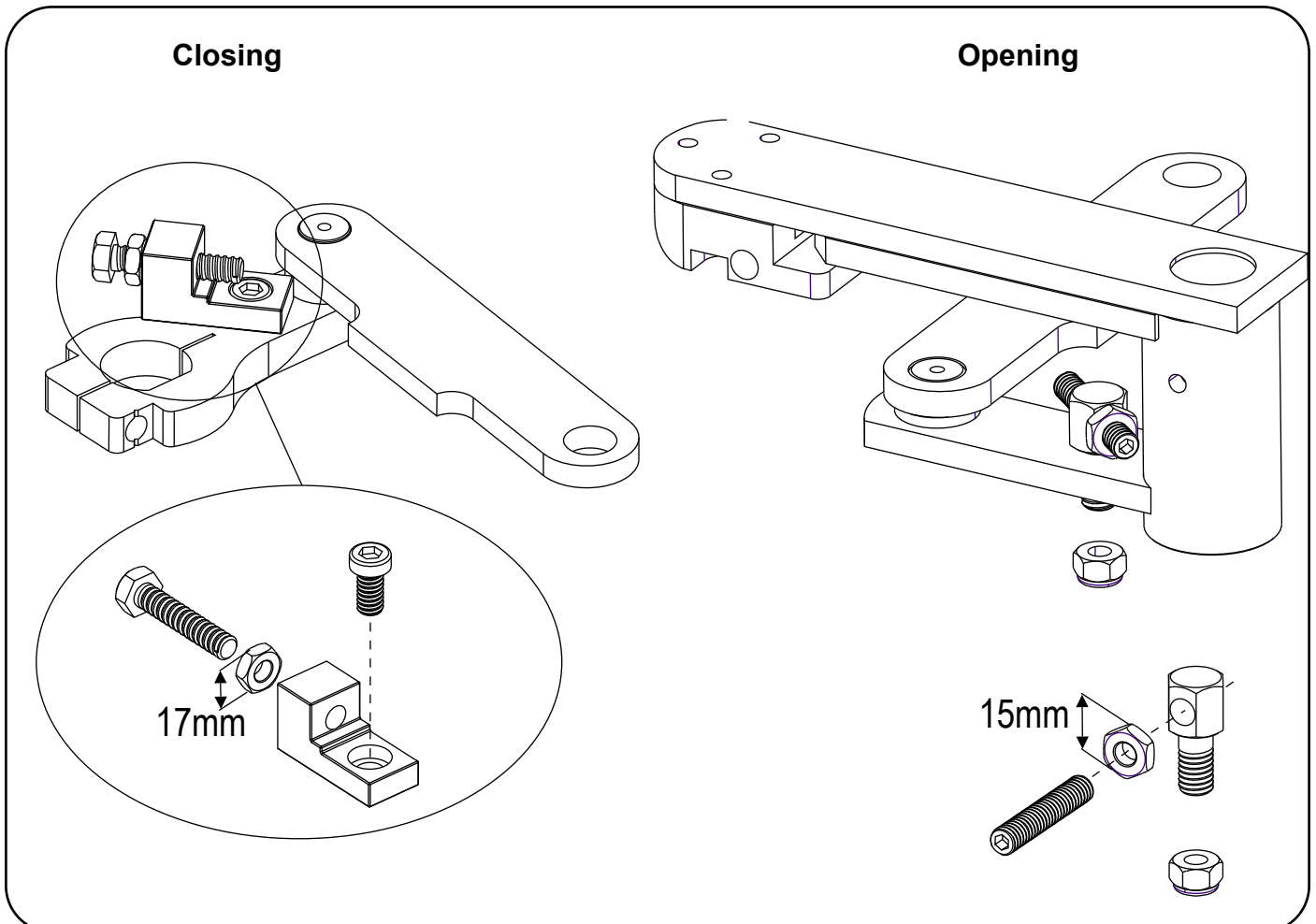

TROUBLESHOOTING

PROBLEM	PROBABLE CAUSE	SOLUTION
On giving a command with the remote control or with the key-switch, the gate doesn't open or the motor doesn't start	230 volt mains voltage absent	Check master switch
	Emergency STOP present	Check for any STOP selectors or commands. If not used, check jumper on STOP contact input on the control board
	Fuse blown	Replace with one of same value.
	Power cable of motor or motors not connected or faulty.	Connect the cable to appropriate terminal or replace.
	The photocell is not functioning or the beam is interrupted	Check the connection, remove any obstacle across the beam
On giving a command with the remote control, the gate doesn't open but works with the key command	The remote control has not been memorised or the battery is flat	Carry out the remote control learning procedure on the radio receiver or replace the battery with a new one..
The gate starts, but stops immediately	The force of the motor or motors is insufficient	Modify the value with the FORCE trimmer on the control unit
One wing opens and the other closes	The connection is not correct	Invert the connection of the cable of the motor which rotates in the wrong sense

N.B. - If the problem persists, contact your Retailer or the nearest Service Centre

GENERAL ADVICE

Install a gate's safety system that complies with current regulations. Choose short routes for cables and keep power cables separate from control ones. Install the control card in a waterproof box.

Please refer to current regulations when setting the gear motor's maximum torque.

We advise you to install an outdoor switch, in compliance with European standards on the issue of safety, to turn the electricity off when servicing the gate.

Check that each single installed device is efficient and effective.

Affix easily readable signs warning about the presence of a motorized gate.

USE

It is absolutely forbidden to use the device for any other purposes. The installed electronic unit (which must have built-in electric friction), allows to select the following functions:

automatic: one control impulse will open or close the gate;

semi-automatic: one control impulse will open or close the gate.

In case of blackout, act on the manual unlocking device and move manually the gate. Remember that this is an automatic device powered by electricity, consequently use with care. In particular, remember:

- not to touch the device with wet hands and/or wet or bare feet;
- to turn off electricity before opening the control box and/or actuator;
- not to pull the lead to pull the plug out;
- to put the gate in movement only when it is completely visible;
- to keep out of the gate's range of action if it is moving. Wait until it has stopped;
- not to let children or animals play near the gate;
- not to let children use the remote control or other operating devices;
- to carry out routine maintenance;
- in case of failure, to turn off electricity and operate the gate manually only if it is possible and safe. Refrain from touching the gate and call an authorized technician.

MAINTENANCE

Actuators need very little maintenance; however their function depends also on the gate conditions, hence here are operations to be done to keep the gate efficient at all times.

Warning: no one but the maintenance man, who must be a specialized technician, must be able to control the automatic gate while it is being serviced. For this reason please turn off electricity, avoiding also electric shocks hazard. If on the contrary electricity must be on for certain checks, remember to check or disable any control device (remote controls, push button panels etc.) except the one used by the service man.

Routine maintenance

Each of the following operations must be done when needed and in all cases at least every 6 months:

1) Mechanical maintenance

- Lubricate (with oilier) the hinges on which the gate swings;
- check the good conditions of brackets and motor's hinges;
- do an unlocking operation to be sure the mechanism is always efficient.

2) Electrical maintenance

- Check the proper working of the safety devices;
- check the electronic friction's efficacy;
- check the earth system's (differential's) efficacy. Try the differential switcher once a month by pushing the special test button on the switcher.

EU Declaration of Conformity

and Declaration of Incorporation of "quasi-machines" (pursuant to the Machinery Directive 2006/42/CE, Att.II, B)



Company name:	QUIKO ITALY SRL
Postal address:	Via Seccalegno, 19
Postcode and City:	36040, Sossano (VI) - Italy
Telephone number:	+39 0444 785513
E-Mail address:	info@quikoitaly.com

declare that the DoC is issued under our sole responsibility and belongs to the following product:

Apparatus model/Product:	SUB: QK-SUB24 ; QK-SUB220
Type:	AUTOMATIONS FOR SWING GATES (24V / 230V)
Batch:	See the label on the motor

The object of the declaration described above is in conformity with the relevant Union harmonisation legislation:

- **Directive 2006/42/CE (MD Directive)**

- It is declared that the relevant technical documentation has been drawn-up in compliance with attachment VII B.
- It is also declared that the following essential health and safety requirements have been respected: 1.1.1 - 1.1.2 - 1.1.3 - 1.1.5 - 1.2.1 - 1.2.6 - 1.3.1 - 1.3.2 - 1.3.3 - 1.3.4 - 1.3.7 - 1.3.9 - 1.5.1 - 1.5.2 - 1.5.4 - 1.5.5 - 1.5.6 - 1.5.7 - 1.5.8 - 1.5.10 - 1.5.11 - 1.5.13 - 1.6.1 - 1.6.2 - 1.6.4 - 1.7.2 - 1.7.3 - 1.7.4 - 1.7.4.1 - 1.7.4.2 - 1.7.4.3.
- The undersigned declares that the afore-mentioned "partly-completed machinery" cannot be commissioned until the final machine, into which it has been incorporated, has been declared compliant with the Machinery Directive 2006/42/CE.
- On duly justified request, the manufacturer commits to transmitting the information regarding the "partly-completed machinery" to the national authorities without prejudice to their intellectual property rights.

- **Directive 2014/53/EU (RED Directive)**

- **Directive 2011/65/EU (RoHS)**

The following harmonised standards and technical specifications have been applied:

Title:	Date of standard/specification
EN 61000-6-2	2005 + AC:2005
EN 61000-6-3	2007 + A1:2011+AC:2012,
EN 301 489-1 V2.2.3	2019
EN 301 489-3 V2.1.1	2017
EN 60335-2-103	2015
EN 12453	2017
EN 62479	2010
EN 300 220-2 V3.1.1	2017
EN IEC 63000	2018

Additional information

Signed for and on behalf of:		
Revision:	Place and date of issue:	Name, function, signature
01.00	Sossano, 28/09/2021	(Borinato Luca, Legal Officer)

DECLARATION OF CONFORMITY
(OF THE INSTALLER)

The undersigned:

in charge of the set-up, declares that the product:

Gate type:

are in compliance with the essential safety requirements of the regulations:

Electro magnetic Compatibility Directive2004/108/EC

Low Voltage Directive2006/95/EC

Machinery Directive2006/42/EC

and also declares that the related and/or specific national technical regulations have been followed:

EN 12453/EN 12445 on Industrial, Commercial and Residential Gates and Doors – Safe Use of Motorized Doors – Requirements and Classification – Test Methods;

EN 12604/ EN 12605 on Industrial, Commercial and Residential Gates and Doors – Mechanical Aspects – Requirements and Classification – Test Methods;

CEI 64/8 Electrical Systems Using Nominal Tension Not Higher Than 1000V a.c. and 1500 V d.c.;

EN 13241-1 (Industrial, commercial and garage doors and gates), conformity evaluation (6.3).

Notes:

Place and date:

QK-BRASUB

Optional curved bracket to make QK-SUB220 gearmotor compatible with pre-installed foundation boxes of other brands
Staffa opzionale per rendere il motoriduttore QK-SUB220 compatibile con casse di fondazione preinstallate di altri marchi

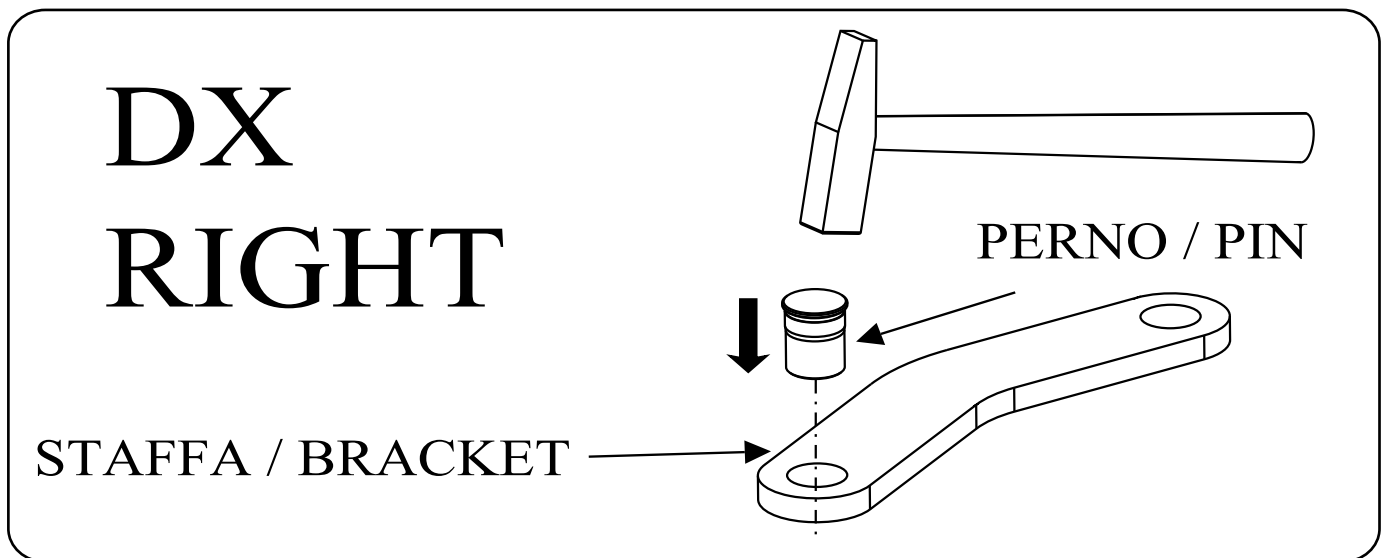
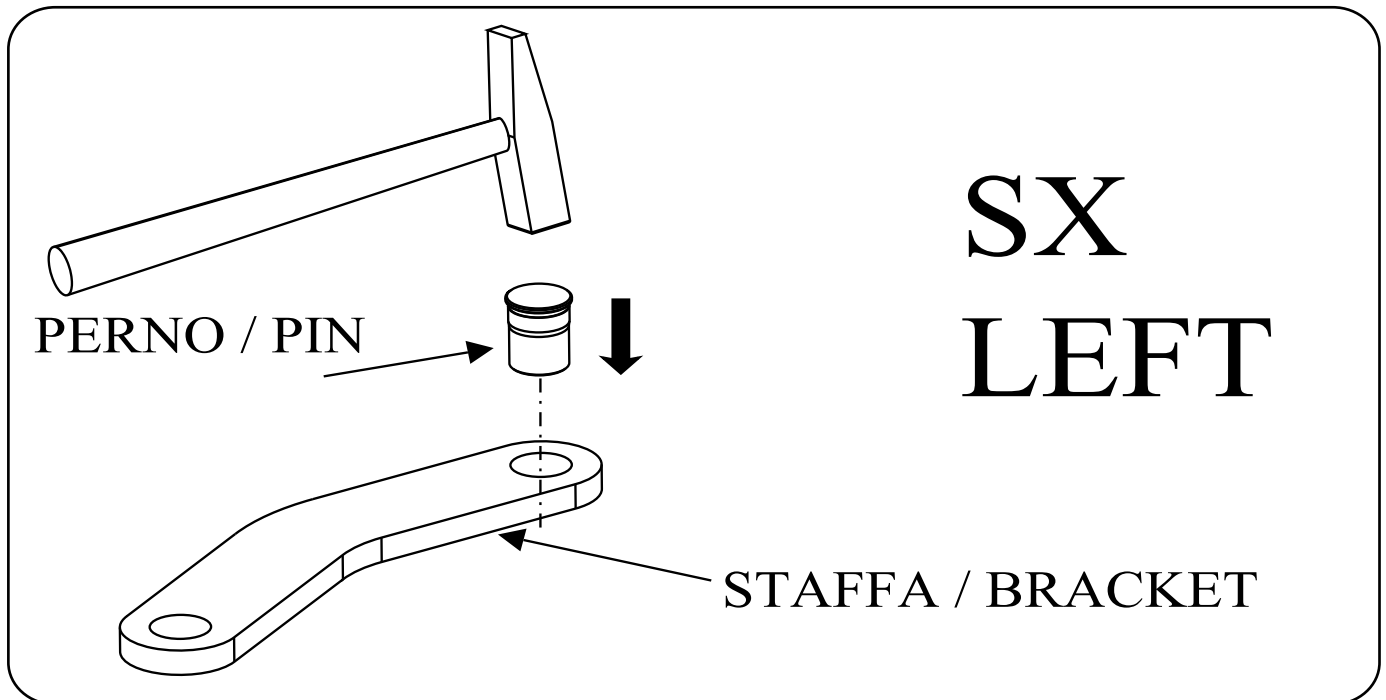



Quiko Italy

Via Seccalegno, 19

36040 Sossano (VI) - Italy

Tel. +39 0444 785513

Fax +39 0444 782371

info@quikoitaly.com

www.quikoitaly.com

