

QK-TW1 PLUS

230Vac SHUTTER MOTOR

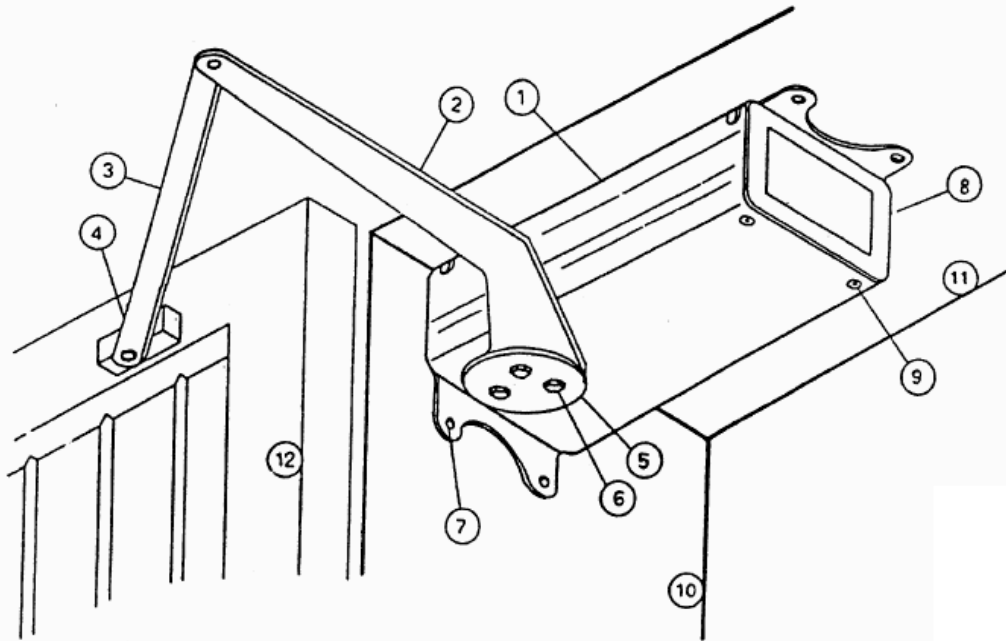

FIG. 1

- | |
|--------------------------------|
| 1. ALUMINUM FRAME |
| 2. ARM |
| 3. ARTICULATED ARM |
| 4. HINGE |
| 5. CLUTCH DISC |
| 6. BOLT M6 |
| 7. FIXING HOLE 6.5 MM DIAMETER |
| 8. CLOSING COVER |
| 9. COVER FIXING SCREW |
| 10. WALL SHOULDER |
| 11. WALL LINTEL |
| 12. RIGHT SHUTTER |

TECHNICAL FEATURES	
POWER SUPPLY	230 VAC
CURRENT ABSORBED	0,8 A
TORQUE	70 Nm
TERMAL PROTECTION	110 °C
WORKING TIME	23 sec
MAX SHUTTER WEIGHT	130 kg
MAX. SHUTTER WIDTH	150 cm
CLUTCH INTERVENTION	:with a wind force of 300 N acting on the arm

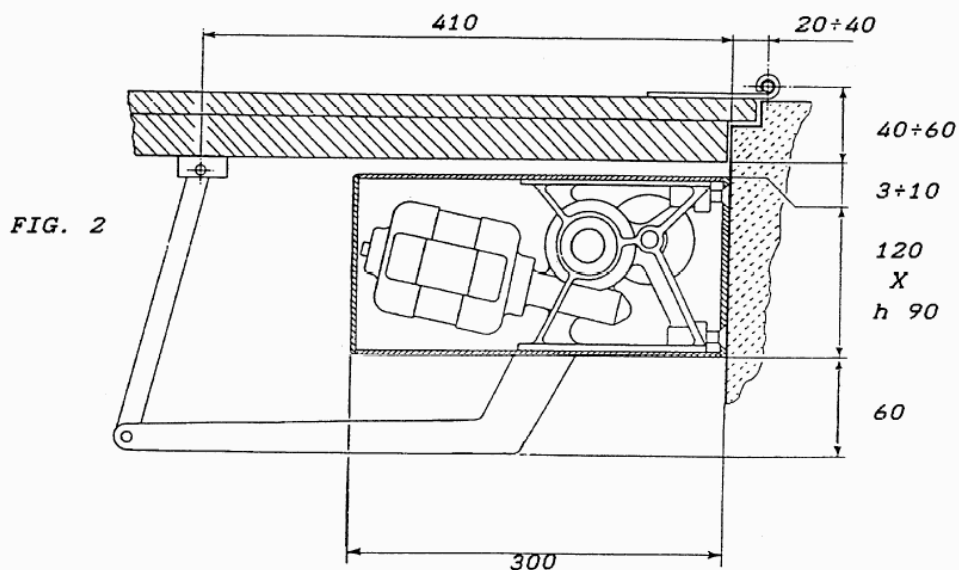

FIG. 2

