

Legend:

- 1 aluminum frame
- 2 cover profile
- 3 arm
- 4 arm extension
- 5 screw for arm extension
- 6 roller track
- 7 roller
- 8 safety clutch
- 9 screw for safety clutch
- 10 fixing bracket
- 11 screw for bracket
- 12 anchor bolt
- 13 screw
- 14 electrical lock (QK-ELSTW) part 1/3
- 15 electrical lock (QK-ELSTW) part 2/3
- 16 electrical lock (QK-ELSTW) part 3/3
- 17 electrical lock (QK-ELS2TW)
- 18 hinge
- 19 wall lintel
- 20 wall shoulder
- 21 windowsill

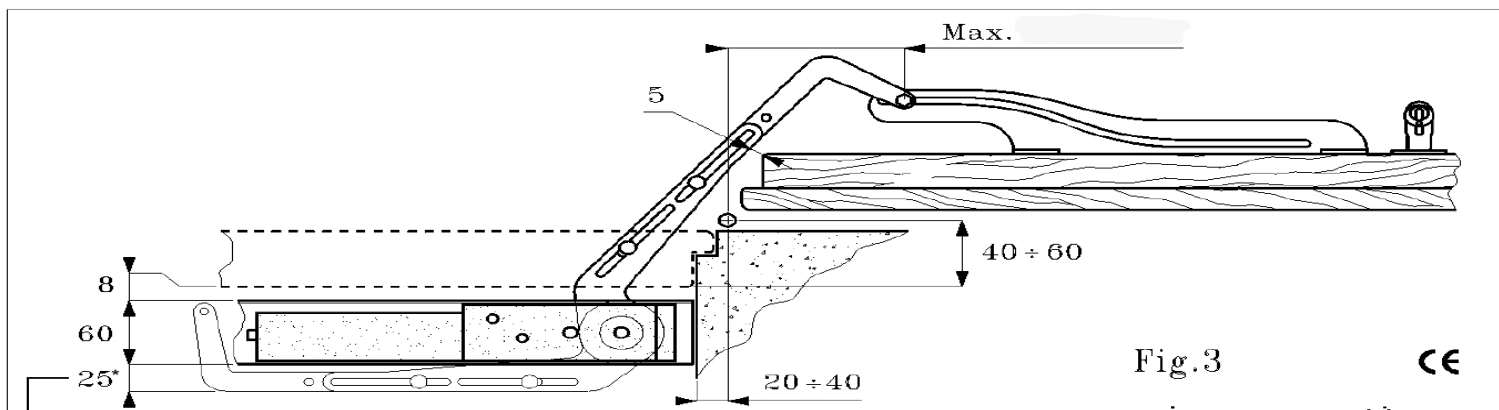

This measure of 25mm must be considered on QK-TW285 model only. In QK-TW2 model this measure is 0mm.

1. For an easy installation and carrying out the manual test unloose the clutch screws (9) until the arms (3) turn freely (Fig. 2);
2. Fasten the bracket (10) to the aluminium frame with the screws (11). The screws shall remain a bit unloose in order to allow the brackets fit the wall shoulder (20);
3. Take away the cover profile (2) starting from the cover end;
4. Connect the electric wires to the terminal following the electric schematic label placed inside the frame (For lateral income the wires overcome the gearmotor);
5. Install the cover profile with the shaped opening faced to the wires route;
6. Attach the aluminium frame under the upper wall frame (lintel) (19) at 8 mm away from the shutter closing position; [Fig.3]

(If the frame is installed on the windowsill (21) it shall be remain left at least 5 mm in order to allow the flowing of the rain water)

7. With a drill of 8mm, make the two holes on the wall using the bracket holes as drilling guide and then insert the anchor bolts and tight the screws (13). Complete the tightening of the screw (11) [Fig.2]

**Arms adjusting** with the shutter completely opened the distance between the hinges (18) and the roller (7) shall be the maximum allowable.

8. Unloose the screws (5) place the roller track (6) on the shutter opened and with the roller inside the track adjust the arm (4) until its distance from the shutter is not more than 5 mm. Tight the screws (5) [Fig.3]

**Roller track fastening** Between the roller (7) and the end of the track shall be remain at least 5 mm both the shutter is open and it is closed [Fig.3] fasten the roller track 5 mm away from the clutch screws (9) [Fig.4]

**WARNING** when the installation is completed it needs fastening the clutch. (8) as follows:

(Completely tight the screws (9) in alternatively in sequence)

**During the normal operation the clutch should never slip.**

(The safety clutch has been designed acting only in case of a strong wind or in manual emergency operations)

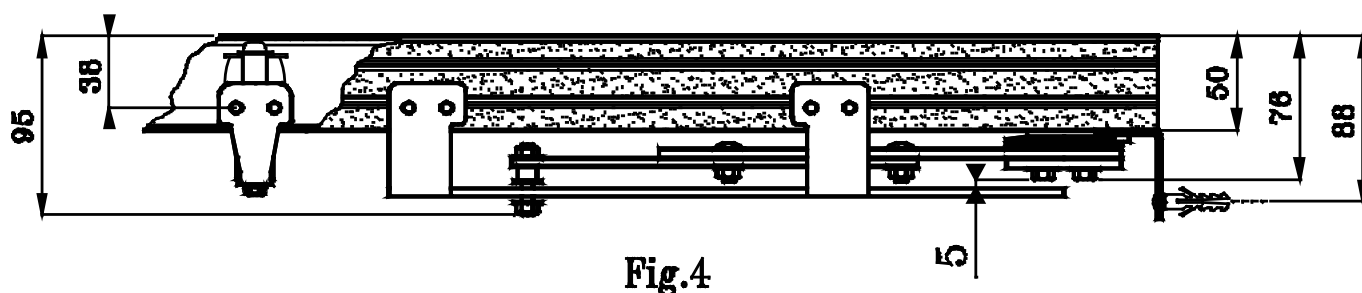

**QK-ELSTW** (14) Electric locking, on request, for the shutters upper lock.

- Install the lock holder (16) being sure when the shutter is closed the QK-ELSTW pin (14) is perfectly inside the hole of the hook (15). [Fig.1]

**QK-ELS2TW** Electric locking, on request, for the shutters lower lock.

- After arranging the electrical connections fasten the lock **QK-ELS2TW** (17) on the lower end of the shutter (the one that closes for last)

Drill on the windowsill (21) a hole 16 mm diameter that shall be, when the shutter is closed, perfectly in the center of the **QK-ELS2TW** 10 mm diameter pin [Fig.1]

**Electrical connections** (two shutters)

- If a control board (QK-CE220BATTW or QK-CE220BATTWU) isn't used, it is needed to provide the electric plant with two double pushbuttons N.O. in order to arrange manually the delay of the shutter opening and closing.