

TERMINAL BLOCK CONNECTION

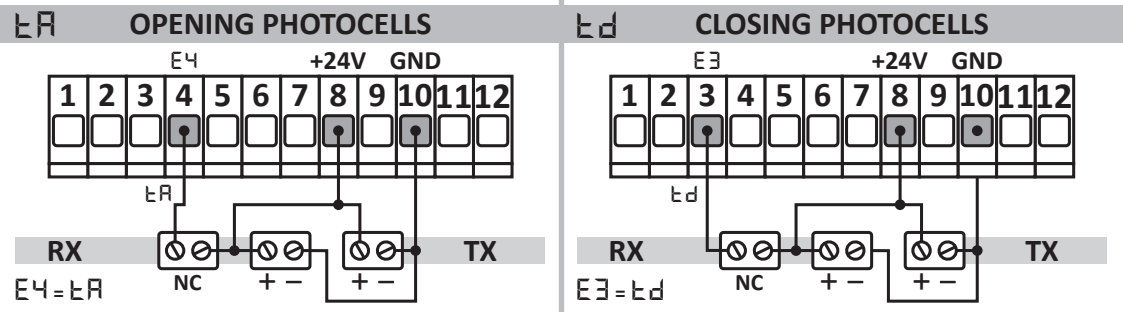

If the motor closes, swap the phases cables of the motor (13-15) as well as limit switch cables (5-6).
L3 = 5 1 DIR1 = CLOSE → DIR2 = OPEN sliding gate default

The control board has three operating modes for different kinds of gate: **SLIDING**, **SWING**, or **DUAL SLIDING**. When powered up the display shows the operating mode set followed by the firmware version. The operating mode can also be viewed by selecting **dt** parameter.

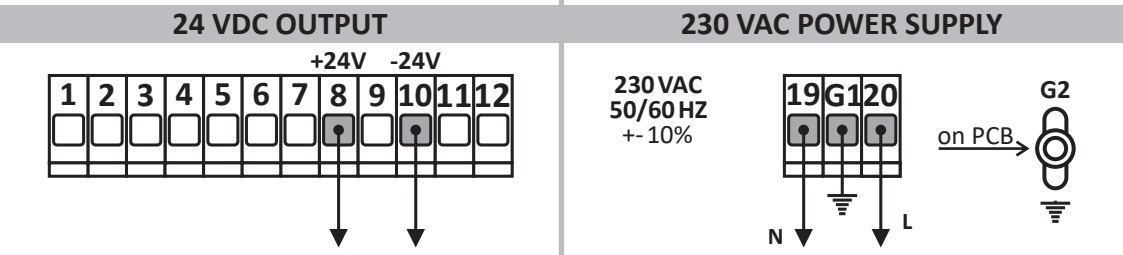
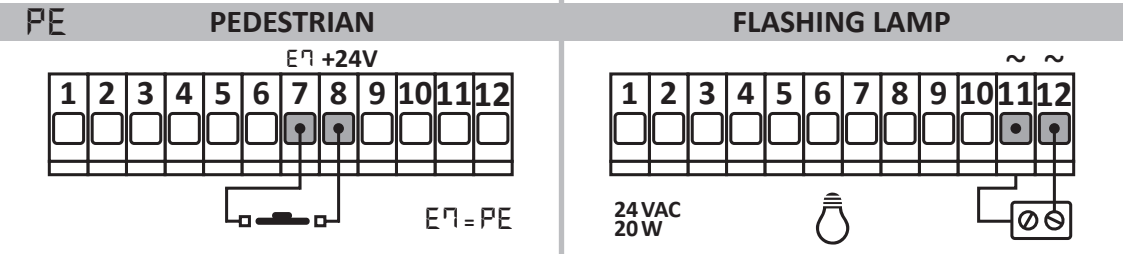
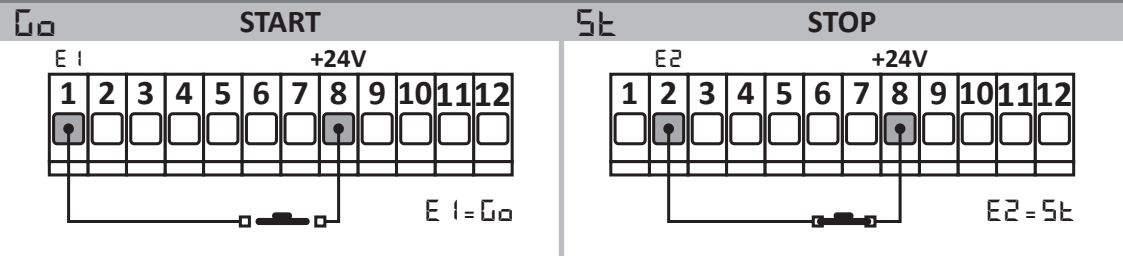

- A UP
 - B DOWN
 - C YES
 - D NO
- H5 SLIDING
 Hb SWING
 HH DOUBLE SLIDING

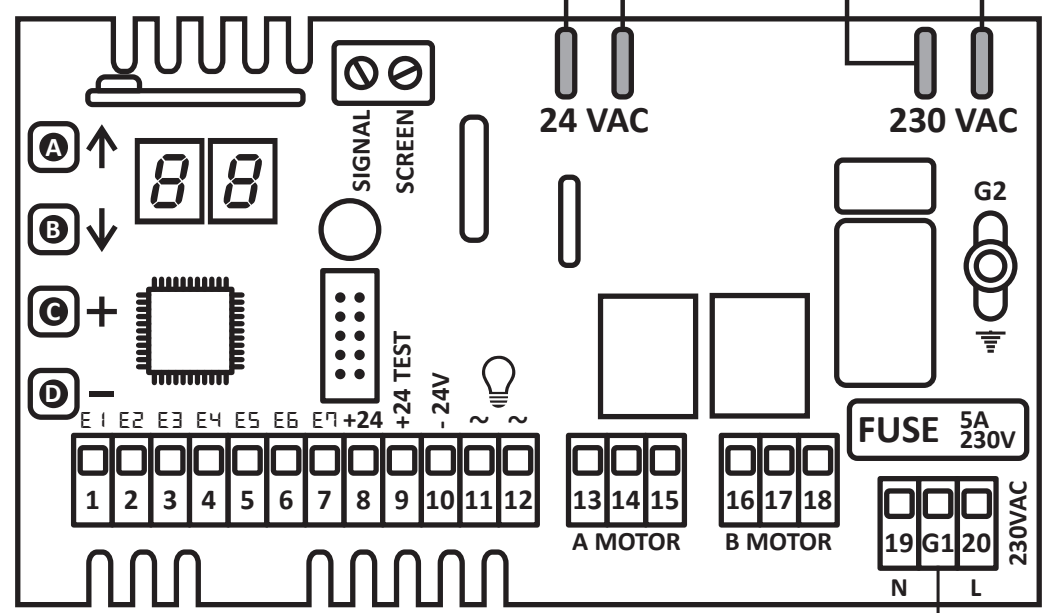

HOW TO CHANGE CONTROL BOARD MODE

- Hold down or keep pressing **BUTTON A** or **B** until display shows **dt**.
- After about one second, the display shows the current opening mode: **H5 Hb HH**
- Hold down **BUTTON C** or **D** of the control board. The display blinks showing the operating mode you are setting.
- When the display stops blinking, the configuration has been set.

CHECKING IF THE MOTORS TURN IN THE RIGHT DIRECTION

Once all the connections have been done and the system is ready to start, before setting the system it is important to check that the motors turn in the right direction. To do that:

- 1 Power supply the control board and check that the display shows **H5 2 1 25**
- 2 Remove electricity.
- 3 Unlock the motor and manually put the leaf in the middle.
- 4 Give electricity.
- 5 Give a first start impulse to the system with remote control or push - button.
- 6 Make sure that the motor opens.
- 7 If the motor closes, swap the phases cables of the motor (13-15) as well as limit switch cables (5-6).
- 8 Once you have swapped motor phases cables as well as limit switch cables, repeat the procedure above and make sure that now the motor opens at first start signal after giving electricity.
- 9 The system is now ready for setup.

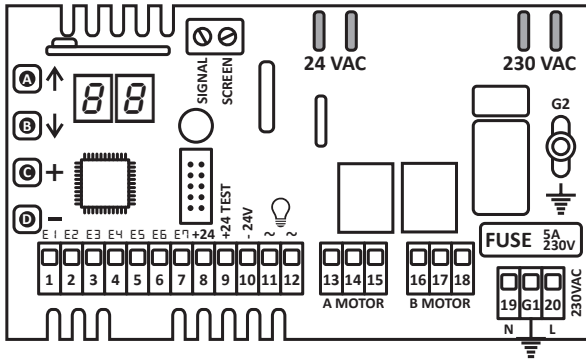

IMPORTANT NOTICE: when you see this symbol please refer to the complete user manual for more details. The complete user manual is available for download in the reserved area of our website. quikoitaly.com

- A UP
- B DOWN
- C YES
- D NO

MENU	HS default	MOTOR A SETTING
A1	30	Standard Working time
A2	10	Slowdown working time
A3	0.1	Start up time
A5	0.7	Standard force
A6	0.8	Slowdown force
A7	∞	C <input type="radio"/> D <input type="radio"/> → from 00 to 99 to ∞
A7	∞	Standard obstacle detection threshold. During opening, for standard working time, the display shows motor A stress.
A8	∞	C <input type="radio"/> D <input type="radio"/> → from 00 to 99 to ∞
A8	∞	Slowdown obstacle detection threshold. During opening, for slowdown working time, the display shows motor A stress.
A9	12	Motor brake duration in centiseconds. Useful to avoid gate getting stuck due to inertia. Set to ∞ to disable.
A6	0.3	Motor brake power. It stops the gate more suddenly when reaching limit switches.

MENU	HS default	FUNCTIONS
F0	10	Automatic closure time. To disable hold down C button until display shows St
F1	0.7	Pedestrian working time
F2	0.0	Kick-back function during closing. It can be useful when an electric-lock is installed.
F3	0.0	Pre-blinking time
F4	∞	Kick-back function during opening. It can be useful when an electric-lock is installed.
F5	0.1	Logic: STANDARD 0.1 COMMUNITY 0.2 STEP-BY-STEP 0.3
F7	5.0	Fast closure delay
F8	5.1	Safety devices as sliding
L0	∞	Electric lock time from ∞ (disabled) to 99 seconds.
L1	∞	Cold winter function. It is useful in countries where the winter is extremely cold.
L3	∞	Swap motor output from A to B
L5	∞	Assistance request from cycle counter
L6	✓	Work cycles counter
L7	0.0	Flashing lamp operating mode 0 = FLASHING LAMP 1 = FIXED LAMP
L8	5.1	Swap motors direction
E1	∞	Photocells test
E2	5.1	Motors thermal protection test 5.1 = ENABLE
o1	0.7	Output 1 function
o2	1.3	Output 2 function

MENU	HS default	REMOTE KEY CONFIGURATIONS
r0	✓	Erase a remote control key: hold down C button on the selected code until display turns off.
r1	✓	Save a remote control key as START: hold down a remote key. When the display shows ∞ push down C button.
r2	✓	Save a remote control key as STOP: hold down a remote key. When the display shows ∞ push down C button.
r3	✓	Save a remote control key as PEDESTRIAN START: hold down a remote key. When the display shows ∞ push down C button.
r4	✓	Save a remote control key as FAST CLOSURE: hold down a remote key. When the display shows ∞ push down C button.
r5	✓	Erase all remotes control keys: hold down C button until display stops flashing 5.1

MENU	HS default	PROGRAMMABLE FUNCTIONS
P0	↑	The function you can select is one of the following: oP Open Only, oL Close Only, P0 Dead Man Open, PC Dead Man Close, EL Electric lock, do dummy output, rE radio range.
PC	↕	
EL	↓	
EL	↓	

MENU	HS default	TERMINAL BLOCKS FUNCTIONS
E1	0.0	Terminal block input 1
E2	∞	Terminal block input 2
E3	∞	Terminal block input 3
E4	∞	Terminal block input 4
E5	FC	Terminal block input 5
E6	FR	Terminal block input 6
E7	PE	Terminal block input 7

MENU	HS default	WORKING TIME PROGRAMMING
P1	✓	1 motor working time programming

MENU	Hb default	RADIO SELECTION
r1	0.1	Internal radio 0.1 ON PCB
r2	0.1	External radio module 0.2 QK-MODRAL4 *optional

MENU	HS default	LOGS
t=	✓	Errors log
r=	✓	Radio log
E=	✓	Input log

MENU	HS default	CONTROL BOARD MODE
do	✓	Restore factory setting selected by dt
dt	✓	← C <input type="radio"/> D <input type="radio"/> → Change control board mode and set its factory setting.

MENU	SAFETY DEVICE DISPLAY REPORT
tA	Opening photocells
td tC	Closing photocells mode 2/1
FH	Opening + Closing photocells
oo tC	Opening / closing 8K2 Safty Edge
St	Stop

MENU	START & SERVICE COMMAND DISPLAY REPORT
Go PE FG	Start / Pedestrian / Fast Closure
oP oL	Open only / Close only
Po PC	Open / Close Dead man
EL	Electric lock
do	Remote key dummy function
Eo	Terminal block dummy function

MENU	LIMIT SWITCHES DISPLAY REPORT
FC LC	Motor A closing limit switch NC / NO
FR LR	Motor A opening limit switch NC / NO
UR UR	Motor B closing limit switch NC / NO
UL UL	Motor B opening limit switch NC / NO
A6	Motor A+B limit switches
1H	Motor A limit switches error
2H	Motor B limit switches error
3H	Motor A+B limit switches error