

TERMINAL BLOCK CONNECTION

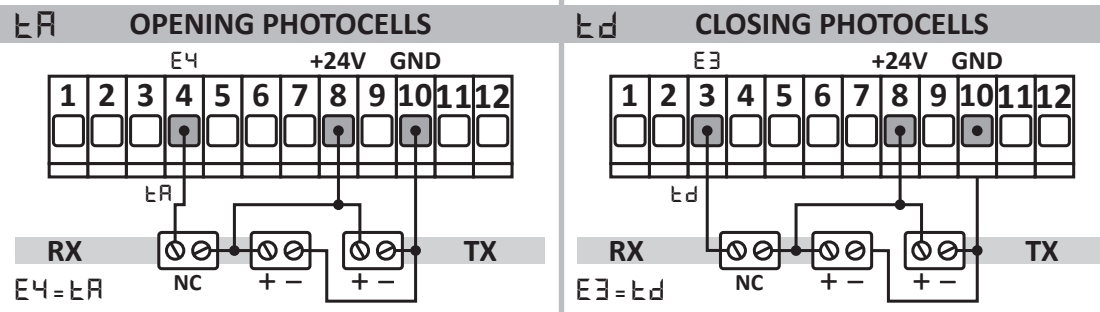

A MOTOR **B MOTOR**

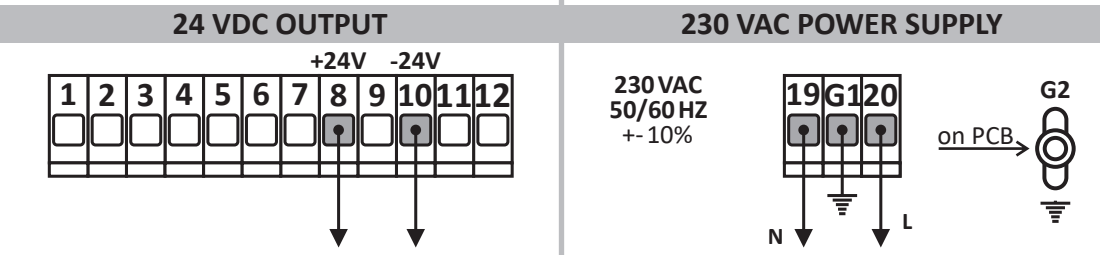
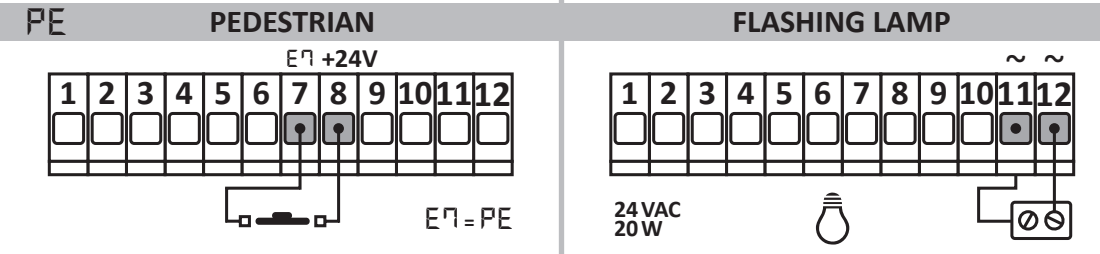
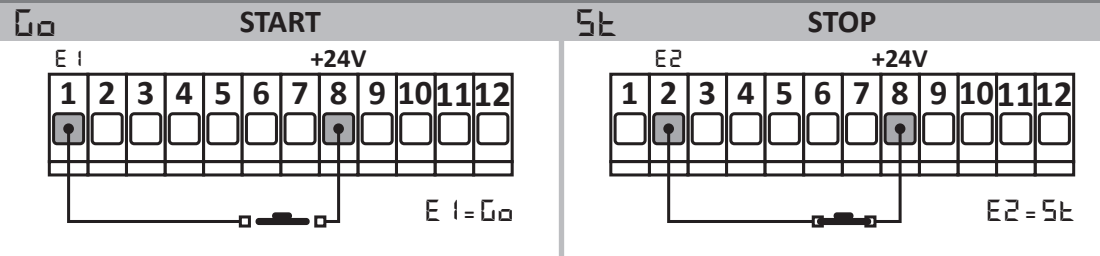
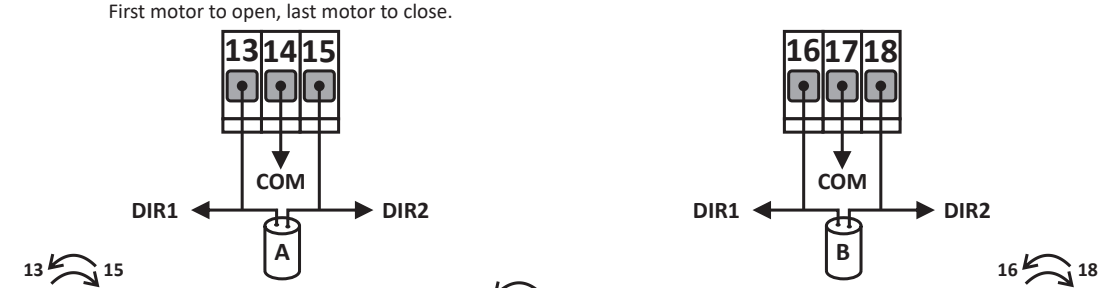

If one or both motors closes instead, swap the phases cables of the motor/s that was closing.

LB = no DIR1 = OPEN → DIR2 = CLOSE swing gate default

The control board has three operating modes for different kinds of gate: **SLIDING**, **SWING**, or **DUAL SLIDING**. When powered up the display shows the operating mode set followed by the firmware version. The operating mode can also be viewed by selecting **dt** parameter.

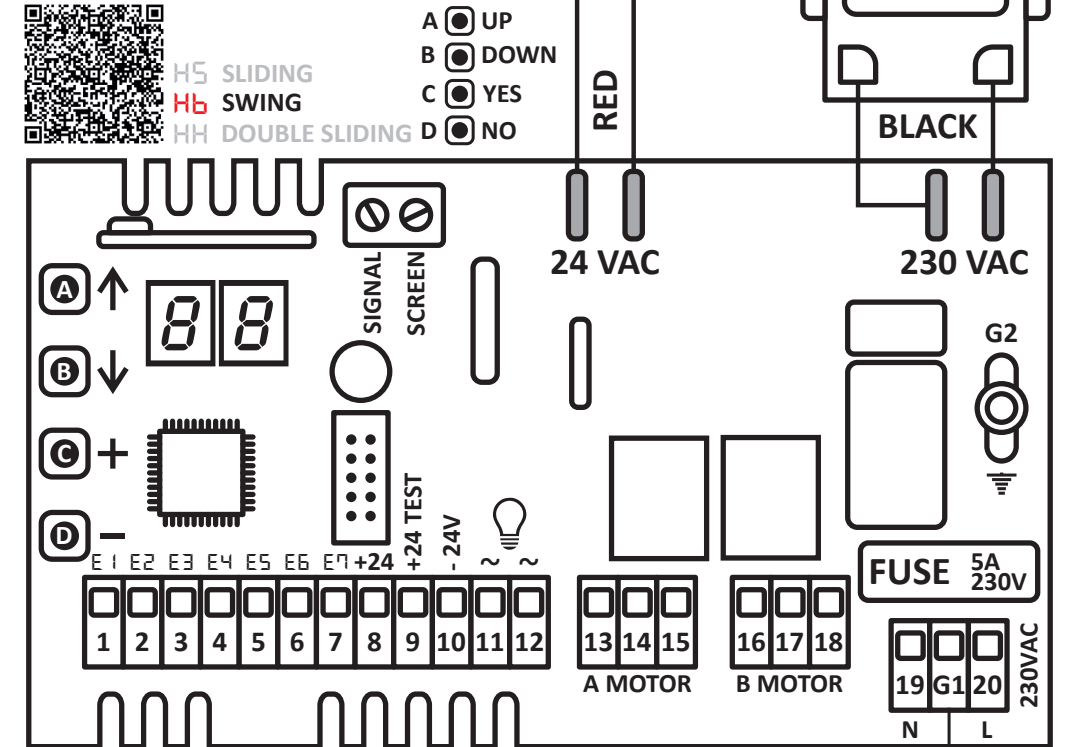

HOW TO CHANGE CONTROL BOARD MODE

- Hold down or keep pressing **BUTTON A** or **B** until display shows **dt**.
- After about one second, the display shows the current opening mode: **H5 Hb HH**
- Hold down **BUTTON C** or **D** of the control board. The display blinks showing the operating mode you are setting.
- When the display stops blinking, the configuration has been set.

CHECKING IF THE MOTORS TURN IN THE RIGHT DIRECTION

Once all the connections have been done and the system is ready to start, before setting the system it is important to check that the motors turn in the right direction. To do that:

- Power supply the control board and check that the display shows **Hb 2125**
- Remove electricity.
- Unlock both motors and manually put the leaves in the middle.
- Give electricity.
- Give a first start impulse to the system with remote control or push - button.
- Make sure that both motors open.
- If one or both motors closes instead, swap the phases cables of the motor/s that was closing.
- Once you have swapped motor/s phases cables, repeat the procedure above and make sure that now both motors open at first start signal after giving electricity.
- The system is now ready for setup.

| MENU | Hb default | MOTOR A SETTING |
|------|------------|--|
| A1 | 14 | Standard Working time |
| A2 | 70 | Slowdown working time |
| A3 | 08 | Start up time |
| A4 | 06 | Displacement time on closure |
| A5 | 06 | Standard force |
| A6 | 08 | Slowdown force |
| A7 | no | C <input type="radio"/> D <input type="radio"/> → from 00 to 99 to no Standard obstacle detection threshold. During opening, for standard working time, the display shows motor A stress. |
| A8 | no | C <input type="radio"/> D <input type="radio"/> → from 00 to 99 to no Slowdown obstacle detection threshold. During opening, for slowdown working time, the display shows motor A stress. |
| AA | no | Final release: motor A open for "0.99" sec at the end of closing to better meet european safety standards. It works with obstacle detection only. |

| MENU | Hb default | MOTOR B SETTING |
|------|------------|--|
| b1 | 14 | Standard Working time |
| b2 | 70 | Slowdown working time |
| b3 | 08 | Start up time |
| b4 | 03 | Displacement time on closure |
| b5 | 06 | Standard force |
| b6 | 08 | Slowdown force |
| b7 | no | C <input type="radio"/> D <input type="radio"/> → from 00 to 99 to no Standard obstacle detection threshold. During opening, for standard working time, the display shows motor B stress. |
| b8 | no | C <input type="radio"/> D <input type="radio"/> → from 00 to 99 to no Slowdown obstacle detection threshold. During opening, for slowdown working time, the display shows motor B stress. |

| MENU | Hb default | WORKING TIME PROGRAMMING |
|------|------------|--|
| P2 | ✓ | 2 motors working time programming |
| P6 | ✓ | Obstacle detection threshold programming |

| MENU | Hb default | CONTROL BOARD MODE |
|------|------------|--|
| d0 | ✓ | Restore factory setting selected by dE |
| dE | ✓ | ← C <input type="radio"/> D <input type="radio"/> → Change control board mode and set its factory setting. |

| MENU | TEST & GATE FUNCTION DISPLAY REPORT |
|-------|-------------------------------------|
| 9A 9b | Motor A/B is in thermal protection |
| 7A 7b | Motor A/B has detected an obstacle |
| 1E | Photocells test error |
| 5L | Assistance request function |



IMPORTANT NOTICE: when you see this symbol please refer to the complete user manual for more details. The complete user manual is available for download in the reserved area of our website quikoitaly.com

| MENU | Hb default | FUNCTIONS |
|------|------------|--|
| F0 | 10 | Automatic closure time. To disable hold down C button until display shows 5E |
| F1 | 07 | Pedestrian working time |
| F2 | 00 | Kick-back function during closing. It can be useful when an electric-lock is installed. |
| F3 | 00 | Pre-blinking time |
| F4 | no | Kick-back function during opening. It can be useful when an electric-lock is installed. |
| F5 | 0 1 | Logic: STANDARD 0 1 COMMUNITY 02 STEP-BY-STEP 03 |
| F7 | 50 | Fast closure delay |
| F8 | no | Safety devices as sliding |
| L0 | no | Electric lock time from no (disabled) to 99 seconds. |
| r1 | no | Cold winter function It is useful in countries where the winter is extremely cold. |
| r5 | no | Assistance request from cycle counter |
| r6 | ✓ | Work cycles counter |
| r7 | 00 | Flashing lamp operating mode 0 = FLASHING LAMP 1 = FIXED LAMP |
| r8 | no | Swap motors direction |
| r1 | no | Photocells test |
| r2 | 5 1 | Motors thermal protection test 5 1 = ENABLE |
| o1 | 07 | Output 1 function QK-RELAY *optional |
| o2 | 13 | Output 2 function These functions are useful when output expansions are used. |

| MENU | Hb default | RADIO SELECTION |
|------|------------|--|
| r6 | 0 1 | Internal radio 0 1 ON PCB |
| | | External radio module 02 QK-MODRAL4 *optional |

| MENU | SAFETY DEVICE DISPLAY REPORT |
|-------|----------------------------------|
| tA | Opening photocells |
| tD tE | Closing photocells mode 2/1 |
| FH | Opening + Closing photocells |
| oo tE | Opening / closing 8K2 Safty Edge |
| 5E | Stop |

| MENU | Hb default | LOGS |
|------|------------|------------|
| t = | ✓ | Errors log |
| r = | ✓ | Radio log |
| E = | ✓ | Input log |

| MENU | START & SERVICE COMMAND DISPLAY REPORT |
|----------|--|
| G0 PE FG | Start / Pedestrian / Fast Closure |
| oP tE | Open only / Close only |
| Po tE | Open / Close Dead man |
| EL | Electric lock |
| do | Remote key dummy function |
| Eo | Terminal block dummy function |

| MENU | Hb default | REMOTE KEY CONFIGURATIONS |
|------|------------|---|
| r0 | ✓ | Erase a remote control key: hold down C button on the selected code until display turns off. |
| r1 | ✓ | Save a remote control key as START: hold down a remote key. When the display shows =_ push down C button. |
| r2 | ✓ | Save a remote control key as STOP: hold down a remote key. When the display shows =_ push down C button. |
| r3 | ✓ | Save a remote control key as PEDESTRIAN START: hold down a remote key. When the display shows =_ push down C button. |
| r4 | ✓ | Save a remote control key as FAST CLOSURE: hold down a remote key. When the display shows =_ push down C button. |
| r5 | ✓ | Erase all remotes control keys: hold down C button until display stops flashing 5 1 |

| MENU | Hb default | PROGRAMMABLE FUNCTIONS |
|------|------------|--|
| r6 | Po | The function you can select is one of the following: oP Open Only, tE Close Only, Po Dead Man Open, tE Dead Man Close, EL Electric lock, do dummy output, rE radio range. |
| r7 | tE | |
| r8 | EL | |
| | | |

| MENU | Hb default | TERMINAL BLOCKS FUNCTIONS |
|------|------------|---------------------------|
| E1 | G0 | Terminal block input 1 |
| E2 | no | Terminal block input 2 |
| E3 | no | Terminal block input 3 |
| E4 | no | Terminal block input 4 |
| E5 | oP | Terminal block input 5 |
| E6 | tE | Terminal block input 6 |
| E7 | PE | Terminal block input 7 |

| MENU | LIMIT SWITCHES DISPLAY REPORT |
|-------|--------------------------------------|
| tE tE | Motor A closing limit switch NC / NO |
| FA LA | Motor A opening limit switch NC / NO |
| UA HA | Motor B closing limit switch NC / NO |
| UC tE | Motor B opening limit switch NC / NO |
| A6 | Motor A+B limit switches |
| 1H | Motor A limit switches error |
| 2H | Motor B limit switches error |
| 3H | Motor A+B limit switches error |