

user manual

QK-CE220RL4

CONTROL BOARD FOR 1 230V MOTOR

IMPORTANT NOTICE:

This user manual can be used also for the same version of control board for 110V motors. Item code of the board becomes **QK-CE110RL4** and:

- all 230/220V within this manual to be read as 110V
- F1 fuse is 10A
- QK-CE110RL4 control board is equipped with a 110V transformer

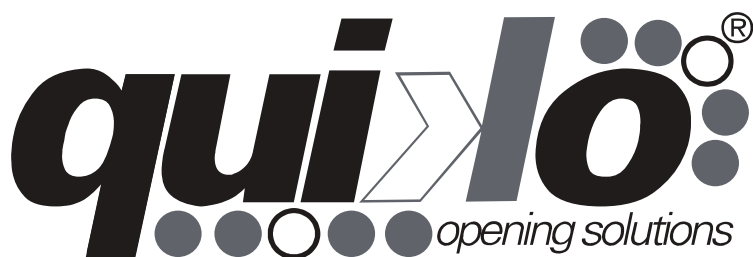
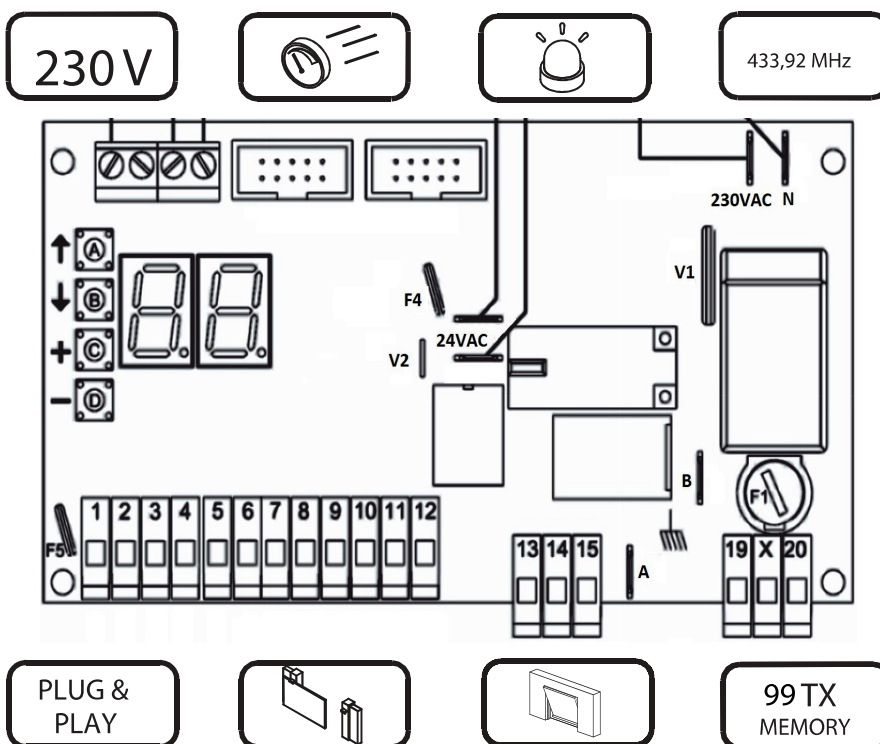

BOARD LAYOUT

PUT INSIDE FLASHING LAMP OR ANTENNA HOUSING TO INCREASE RANGE OF RADIO SIGNAL (pag 3).

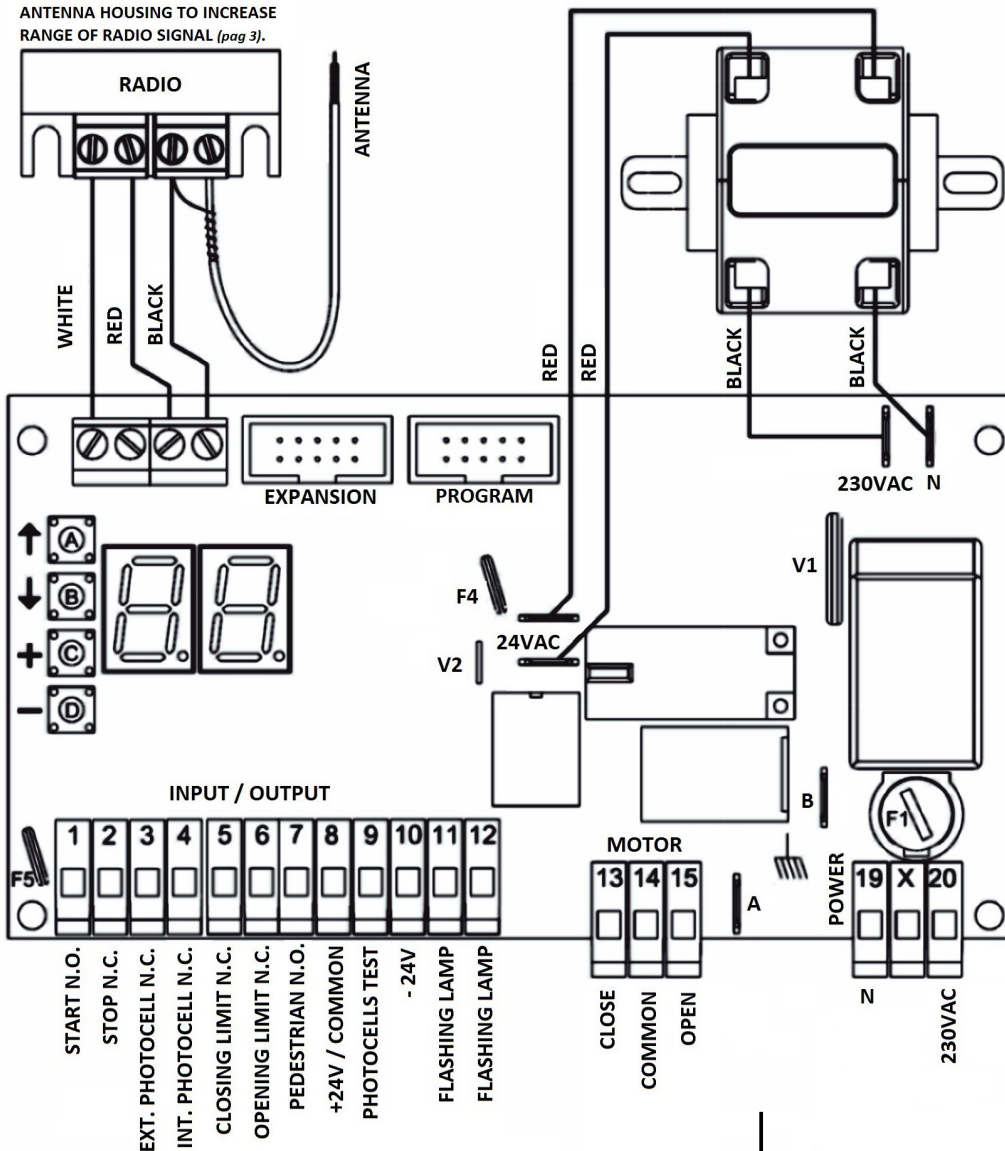

BOARD'S COMPONENTS

A	Button A
B	Button B
C	Button C
D	Button D
F1	250 VAC power fuse 5A
F4	Resettable fuse 24V 1.6A
F5	Resettable fuse 24V 0.6A
A B	Ground terminals
V1	Primary varistor
V2	Secondary varistor
1 to 20	Terminal block pins

IMPORTANT

RESETTABLE FUSES

AFTER SHORT-CIRCUIT



F4/F5

TURN OFF THE CONTROL BOARD. REMOVE THE SHORT-CIRCUIT. WAIT FOR 60 SECONDS OR MORE. TURN ON THE CONTROL BOARD.

INPUTS CONNECTION

EXTERNAL PHOTOCELL	24 VDC POWER SUPPLY		TYPE	PIN	CONFIG. PARAMETER
TRANSMITTER	8 +	10 -	N.C.	X X	E 3
RECEIVER				3 8	

INTERNAL PHOTOCELL	24 VDC POWER SUPPLY		TYPE	PIN	CONFIG. PARAMETER
TRANSMITTER	8 +	10 -	N.C.	X X	E 4
RECEIVER				4 8	

OTHER INPUTS	TYPE	PIN	CONFIG. PARAMETER
START – OPEN ONLY – CLOSE ONLY	N.O.	1 8	E 1
PEDESTRIAN – OPEN ONLY – CLOSE ONLY	N.O.	7 8	E 7
STOP	N.C.	2 8	E 2
CLOSING LIMIT SWITCH	N.C.	5 8	E 5
OPENING LIMIT SWITCH	N.C.	6 8	E 6

N.C. Normally Closed

N.O. Normally Open

OUTPUTS CONNECTION

MOTOR	CLOSE	COMMON	OPEN
MOTOR	13	14	15

24V FLASHING LAMP (20W) PINS

11	12
----	----

24VDC (150 mA) PINS

8 +	10 -
-----	------

POWER SUPPLY

230 VAC POWER SUPPLY PINS

19	20
----	----

FUNCTION SUMMARY

Motor Setting

DISPLAY	DEFAULT	□ C MAX	□ D MIN	DESCRIPTION
R1	30 sec	99 sec	00 sec	Standard working time
R2	10 sec	99 sec	00 sec	Slowdown working time
R3	0.1 sec	1.5 sec	0.1 sec	Start up time
R5	7	10	1	Standard force
R6	8	10	1	Slowdown force
R7	NO (DISABLED)	99 - NO	0	Standard obstacle detection threshold. During opening and closing, for the standard working time, the display shows the motor stress.
R8	NO (DISABLED)	99 - NO	0	Slowdown obstacle detection threshold. During opening and closing, for the slowdown working time, the display shows the motor stress.

Courtesy Functions

DISPLAY	DISPLAY	□ C	DESCRIPTION
d0	n0	Set Up	To restore default setting hold down □ c button until display shows □□
P1	- -	x	When a start command is received the control board starts an automatic procedure to acquire the gate working times.

General Functions

DISPLAY	DEFAULT	□ C MAX	□ D MIN	DESCRIPTION
F0	10 sec	99 sec	00 sec	Pause time. To disable hold down □ c button until display shows 5E
F1	7 sec	R1 sec	0 sec	Pedestrian working time. It is the motor working time during a pedestrian working cycle.
F2	0.0 sec	1.0 sec	0.0 sec	Kick back function during closing.
F3	0.0 sec	5.0 sec	00 sec	Pre-blinking time
F4	NO (OFF)	SI (ON)	NO (OFF)	Kick back function during opening.
F5	NO (OFF)	SI (ON)	NO (OFF)	Step-by-step function
F6	NO (OFF)	SI (ON)	NO (OFF)	Community mode
F8	SI	SI	NO	Photocells logic: 51 → Standard logic n0 → Reverse logic
L1	00 min	10 min	00 min	Cold winter function. This function is useful in countries where the winter is extremely cold.
L2	NO (OFF)	SI (ON)	NO (OFF)	Recovery loop function. This function is useful to avoid motor lock due to gate inertia.
E1	NO (OFF)	SI (ON)	NO (OFF)	Photocells test
E2	SI (ON)	SI (ON)	NO (OFF)	Motor thermal protection test

Terminal Block Settings

DISPLAY	DEFAULT	□ C	□ D	DESCRIPTION
E1	G0	↓	↑	n0 = Disabled. G0 = Start N.O. oP = Open only N.O. CL = Close only N.O.
E2	n0	↓	↑	n0 = Disabled. 5E = Stop N.C.
E3	n0	↓	↑	n0 = Disabled. E1 = External photocell N.C.
E4	n0	↓	↑	n0 = Disabled. E1 = Internal photocell N.C.
E5	FC	↓	↑	n0 = Disabled. FC = Closing limit switch N.C. LC = Closing limit switch N.O.
E6	FR	↓	↑	n0 = Disabled. FR = Opening limit switch N.C. LR = Opening limit switch N.O.
E7	PE	↓	↑	n0 = Disabled. PE = Pedestrian N.O. oP = Open only N.O. CL = Close only N.O.

N.O. → Normally Open

N.C. → Normally Closed

Radio Functions

DISPLAY	DISPLAY	□ C	DESCRIPTION
r0	1...2...	Delete	To erase a code: Hold down □ c button on the selected code until the display turns off □□
r1	E -	Save	To save a remote key: Hold down a remote key. When the display shows E., push down □ c button on the control board. The control board holds up to 99 codes.
r2	E -	Save	To save a remote key: Hold down a remote key. When the display shows E., push down □ c button on the control board. The control board holds up to 99 codes. r1 → Start r2 → Stop r3 → Pedestrian start r4 → Fast closure start
r3	E -	Save	
r4	E -	Save	
r5	n0	Delete	To erase all codes: Hold down □ c button until display stops flashing 51

Display Report

5E	Stop.
FH	External photocell + Internal photocell.
EC	External photocell.
ER	Internal photocell.
oP	Open Only.
CL	Close Only.
IH	Opening limit switch + Closing limit switch.
FR	Opening limit switch. Normally Closed.
FC	Closing limit switch. Normally Closed.
LR	Opening limit switch. Normally Open.
LC	Closing limit switch. Normally Open.
L2	Recovery Loop is running.
- -	Remote key is pressed.
1E	Photocells test error.
7A	Motor has detected an obstacle during the standard working time.
8A	Motor has detected an obstacle during the slowdown working time.
9A	Motor is in thermal protection state.
FF	The radio memory is full.

BUTTONS

- A Scrolls menu from R1 to P2
- B Scrolls menu from P2 to R1
- C Increases value or set 51 (means: ON or ENABLED).
- D Decreases value or set n0 (means: OFF or DISABLED).

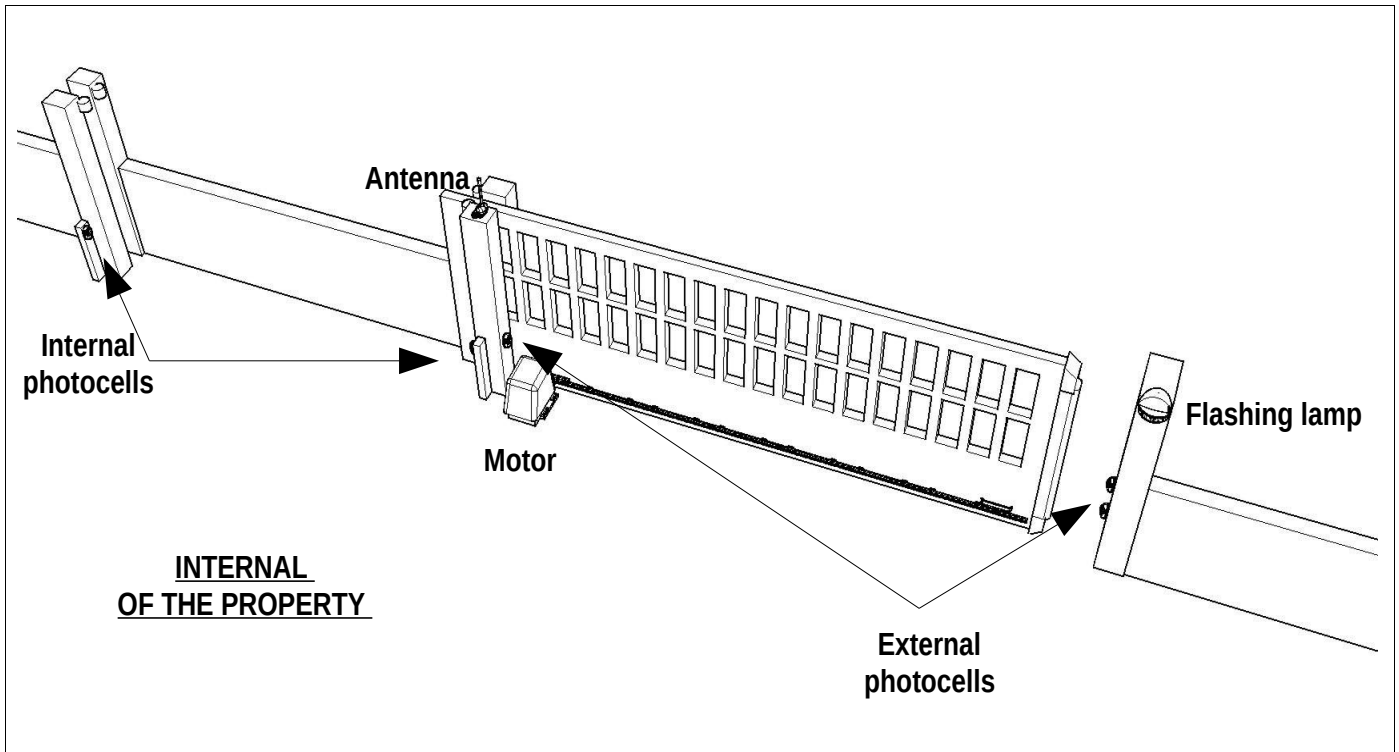

INSTALLING RADIO MODULE

INSIDE THE ANTENNA HOUSING
OPTIONAL QK-AN433_V4

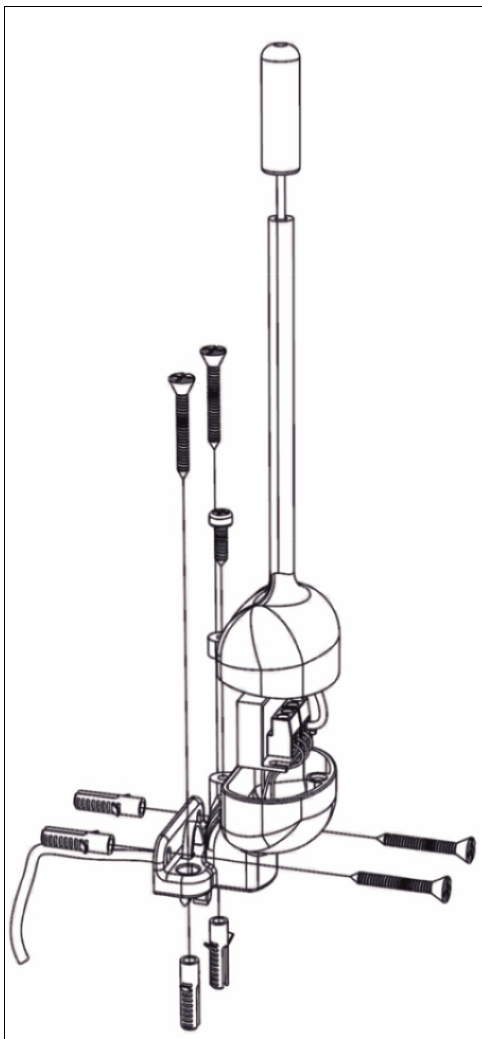

INSIDE THE FLASHING LAMP

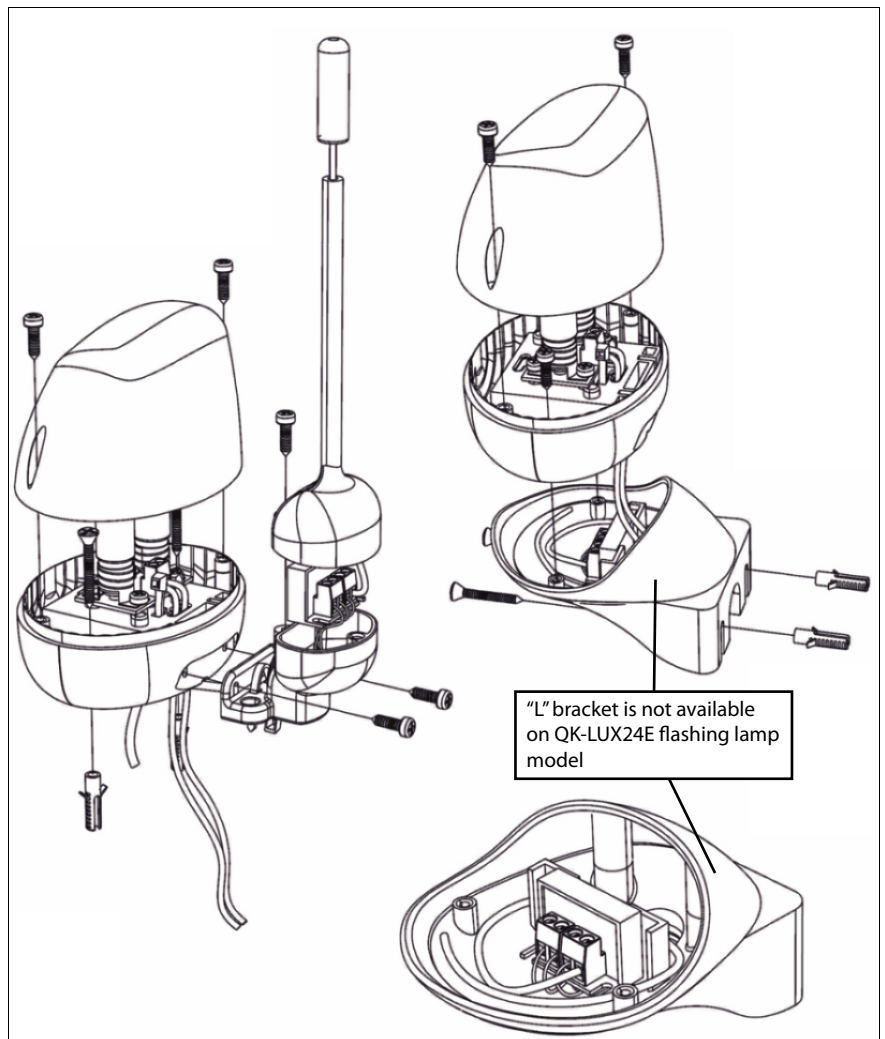

INPUT/OUTPUT CONNECTIONS

230 VAC POWER SUPPLY

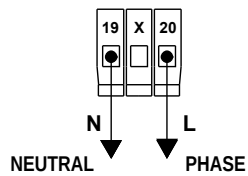

PEDESTRIAN START

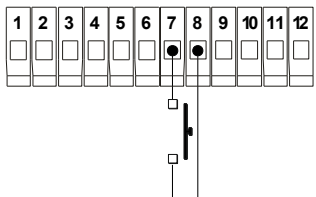

START

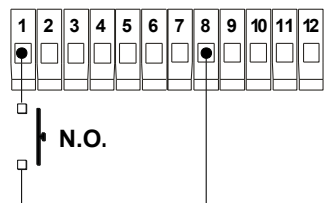

STOP

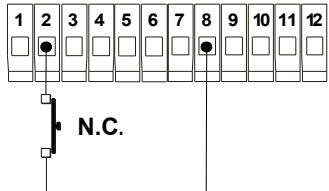

CLOSING LIMIT SWITCH

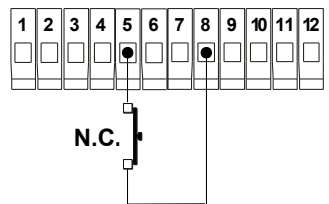

OPENING LIMIT SWITCH

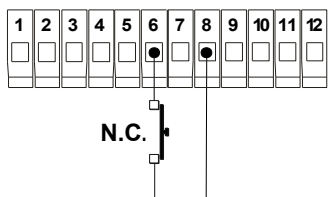

230 VAC MOTOR

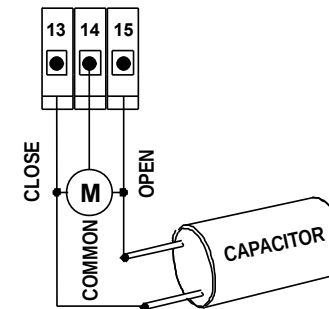

FLASHING LAMP

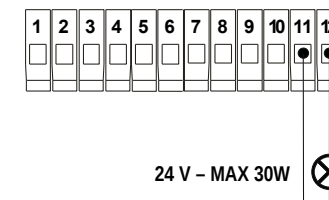

24V DC - 150mA

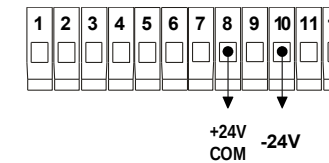

	INTERNAL PHOTOCELL	EXTERNAL PHOTOCELL
PHOTOCELLS RECEIVER		
(4.A) PHOTOCELLS TRANSMITTER WITHOUT PHOTO TEST FUNCTION		
(4.B) PHOTOCELLS TRANSMITTER WITH PHOTO TEST FUNCTION		
(4.C) DISABLED BY HARDWARE		
(4.D) DISABLED BY SOFTWARE	Set $E4$ to no	Set $E3$ to no

The parameter $E1$ enables (51) or disables (no) the test of photocells. Settings **(4.A)** and **(4.C)** require $E1$ set to no .

Stand By	The gate is completely closed and the safety devices are unactivated. The control board is ready to start a working cycle. In this state the flashing lamp is off.
Opening	The gate is opening and the flashing lamp blinks quickly.
Pause	During pause the motor is stopped and the flashing lamp is on. After pause time has expired (F10) the gate starts closing.
Closing	The gate is closing and the flashing lamp blinks slowly.
Stop opening	The gate has been stopped while it was opening. A new start command begins the closing phase. In this state the flashing lamp is off.
Stop closing	The gate has been stopped while it was closing. A new start command begins the opening phase. In this state the flashing lamp is off.
Types of Input	<p>There are two types of input: external and remote control. The external inputs are all devices (photocells, normally closed contacts and normally open contacts) wired to the terminal blocks. Each input is programmable with a function. The safety functions match the normally closed contacts. The other functions match the normally open contacts. The safety functions are: stop, internal photocell, external photocell, opening limit switches N.C. and closing limit switches N.C. The other functions are: start, pedestrian start, opening limit switches N.O. and closing limit switches N.O. The functions of terminal block inputs are configurable by parameters E1, E2, E3, E4, E5, E6 and E7.</p> <p>A remote control input is programmable as: start, stop, pedestrian start and fast closure start. The remote controls are configurable by parameters r1, r2, r3, r4.</p> <p>The control board doesn't distinguish between the type of input but only between the functions.</p>
Input Is activated	<p>An input is activated when its state changes from the standard state. For instance, a photocell is activated when the beam from the transmitter to the receiver is interrupted. While a generic push-button or a remote key is activated only when it is pushed down.</p> <p>All these actions are recognized by the control board which shows these changes on the display.</p> <p>When more inputs are activated at the same time the display shows only the most important input. The order from the most important to the least important input is: stop S1, internal and external photocells F11, external photocells E1, internal photocells E2, start C0, pedestrian start P1, open only O1, close only C1, Opening and Closing limit switches I1, Closing limit switch N.C. F1, Opening limit switch N.C. F2, Closing limit switch N.O. L1, Opening limit switch N.O. L2.</p>
Start commands	<p>The start commands are: start, pedestrian start, open and fast closure start. They are able to start a working cycle. The function of start commands depend on F5 and F6 parameters programming.</p> <p>To know more see F5 and F6 description.</p> <p>To know how the fast closure start command works see r4 description.</p> <p>To know how the start command works see Standard Working Cycle.</p> <p>To know how the pedestrian start command works see Pedestrian Working Cycle.</p>
Safety commands	<p>The safety commands are: stop, internal photocell and external photocell.</p> <p>The stop commands always stop the gate. Instead the functions of photocells depend on F8 parameter programming. To know more see F8 description.</p>
Standard working cycle	<p>A standard working cycle begins when an input programmed as start, open or fast closure is activated and the control board is in stand by.</p> <p>The motor works for a total time of R1 plus R2 seconds during the opening and the closing. When a standard working cycle is in progress, the pedestrian start commands are considered as a start. The working cycle is finished when the control board returns to stand by state. This functionality can be handled by parameters programming. The working cycle finishes when the control board returns to stand by. This functionality can be handled by parameters F0, F5, F6.</p>
Pedestrian working cycle	<p>A pedestrian working cycle begins when a pedestrian start is activated and the control board is in stand by.</p> <p>The motor works for a total time of F1 seconds during the opening and closing. The slowdown phase is skipped during the opening and executed during the closing. The slowdown time is automatically managed by the control board during a pedestrian working cycle. When a pedestrian working cycle is in progress, the start commands are considered as a pedestrian start. The working cycle is finished when the control board returns to stand by state.</p>

Standard Working Time <div style="border: 1px solid black; padding: 2px; width: 40px; margin: 0 auto; text-align: center;">R1</div>	<p>The motor works for R1 seconds. After this time the motor starts the slowdown for R2 seconds. This is for both phases: opening and closing.</p> <p>R1 is settable from 00 to 99 seconds. R2 is settable from 00 to 99 seconds.</p>
Slowdown Working Time <div style="border: 1px solid black; padding: 2px; width: 40px; margin: 0 auto; text-align: center;">R2</div>	
Start Up Time <div style="border: 1px solid black; padding: 2px; width: 40px; margin: 0 auto; text-align: center;">R3</div>	<p>R3 is the start up time of the motor. During this time the force of the motor increases constantly until it reaches the maximum power and the obstacle detection sensor is disabled. Each time the motor start, the first R3 seconds are the start up time.</p> <p>R3 is settable from 0.1 to 1.5 seconds.</p>
Standard Force <div style="border: 1px solid black; padding: 2px; width: 40px; margin: 0 auto; text-align: center;">R5</div>	<p>R5 is the force of the motor during the standard working time R1.</p> <p>R5 is settable from 00 to 10</p>
Slowdown Force <div style="border: 1px solid black; padding: 2px; width: 40px; margin: 0 auto; text-align: center;">R6</div>	<p>R6 is the force of the motor during the slowdown working time R2.</p> <p>R6 is settable from 00 to 10</p>
Standard Obstacle Detection Threshold <div style="border: 1px solid black; padding: 2px; width: 40px; margin: 0 auto; text-align: center;">R7</div>	<p>During the standard working time R1, when the motor stress is higher than R7: The control board makes a decision in accordance with its programming as described in SENSOR OPERATING MODE (see page 7). When the motor is on and the standard working time is in progress, the control board display shows the motor stress. You can use this value as a feedback value. 00 is the minimum and 99 is the maximum. The maximum value depends on the motor and can be lower than 99. To disable the obstacle detection sensor during the standard working time R1 set R7 = n0. To set R7 = n0 hold down or keep pressing button C. R7 is settable from 00 to 99. After 99 the display shows n0.</p>
Slowdown Obstacle Detection Threshold <div style="border: 1px solid black; padding: 2px; width: 40px; margin: 0 auto; text-align: center;">R8</div>	<p>During the slowdown working time R2, when the motor stress is higher than R8: The control board makes a decision in accordance with its programming as described in SENSOR OPERATING MODE (see page 7). When the motor is on and the slowdown is in progress, the control board display shows the motor stress. 00 is the minimum, 99 is the maximum. The maximum value depends on the motor and can be lower than 99. To disable the obstacle detection sensor during the slowdown working time R2 set R8 = n0. To set R8 = n0 hold down or keep pressing button C. R8 is settable from 00 to 99. After 99 the display shows n0.</p>

There are two sensor operating mode: Obstacle Detection and Limit switch. They are described in the table below:













Obstacle Detection	Limit Switch
In this operating mode the motor changes direction. If the direction was closure, the gate opens completely. If the direction was opening, the gate closes for 2 seconds. After this time, it stops. A start command will restart the closing. This functionality is active once per working cycle. For additional times during the cycle the sensor works as a limit switch.	In this operating mode the motor finishes the working phase: from Opening to Pause, from Closing to Stand by.

























The operating mode depends on the working phase and parameters programming. The working phases are: opening, opening slowdown, closing, closing slowdown. The relevant parameters are: $R2$, $R7$, $R8$, $E5$, $E6$.

- If $R7$ is set to $n0$ the sensor is disabled during the standard working time. This means that it doesn't work in any operating mode during the standard working time ($R1$).
- If $R8$ is set to $n0$ or $R2$ is equal to 00 the sensor is disabled during the slowdown working time. This means that it doesn't work in any operating mode during the slowdown working time ($R2$).
- If the limit switches inputs are installed ($E5=51$ and $E6=51$): the sensor works in obstacle detection mode.
- If the opening limit switch input is not installed ($E6=n0$) and the opening is in progress: the sensor works in obstacle detection mode during the standard working time ($R1$). During the slowdown ($R2$) the sensor works in limit switch mode.
- If the opening limit switch input is not installed ($E6=n0$) and the slowdown phase is disabled ($R2 = 00$): the sensor works in limit switch mode during the opening.
- If the closing limit switch input is not installed ($E5=n0$) and the closing is in progress: the sensor works in obstacle detection mode during the standard working time ($R1$). During the slowdown ($R2$) the sensor works in limit switch mode.
- If the closing limit switch input is not installed ($E5=n0$) and the slowdown phase is disabled ($R2 = 00$): the sensor works in limit switch mode during the closing.
- If both limit switches inputs are not installed ($E5=n0$ and $E6=n0$): the sensor works in obstacle detection mode during the standard working time ($R1$). During the slowdown working time ($R2$) the sensor works in limit switch mode.
- If both limit switches inputs are not installed ($E5=n0$ and $E6=n0$) and the slowdown phase is disabled ($R2 = 00$): the sensor works in limit switch mode.

OPERATING MODE WORKING PHASE	<i>Obstacle Detection</i>	<i>Limit Switch</i>	<i>Disabled</i>
Opening	$E6 = 51$ or $E6 = n0$ and $R2$ enabled	$E6 = n0$ and $R2$ disabled	$R7 = n0$
Opening Slowdown	$E6 = 51$	$E6 = n0$	$R8 = n0$ or $R2$ disabled
Closing	$E5 = 51$ or $E5 = n0$ and $R2$ enabled	$E5 = n0$ and $R2$ disabled	$R7 = n0$
Closing Slowdown	$E5 = 51$	$E5 = n0$	$R8 = n0$ or $R2$ disabled

GENERAL FUNCTIONS

Automatic Closure Time 	After the opening the gate waits for $F0$ seconds before beginning the closing. To disable the automatic closure set $F0 = 5E$. To set $5E$ hold down or keep pressing button C until the display shows $5E$.		
Pedestrian Working Time 	It is the motor working time during a pedestrian working cycle . The slowdown phase is skipped during the opening and executed during the closing. The slowdown time is automatically managed by the control board during a pedestrian working cycle . $F1$ is settable from 00 to $A1$.		
Kick Back Function During Closing 	When the gate is closing and the slowdown is finished, a ramp pulse is executed by motor A. This pulse is $F2$ seconds long and the obstacle detection sensor is disabled for the same amount of time. After the pulse the closing phase is finished. $F2$ is settable from 0.0 to 1.0 seconds		
Pre-blinking Time 	Before starting the motor, the flashing lamp blinks for $F3$ seconds. After this time the flashing lamp still blinks and the motor start moving. $F3$ is settable from 0.0 to 5.0 seconds		
Kick Back Function During Opening 	$F4 = 5I$ → ENABLED $F4 = A0$ → DISABLED Before normal opening the motor closes for 0.5 seconds. During this time the force of motor is set to maximum power and the obstacle detection is disabled.		
Start Commands Functionality  	STANDARD SETTING $F6 = A0$ and $F5 = A0$ <u>During the opening:</u> The start commands stop the opening. <u>During the closing:</u> The start commands stop the closing and begin the opening.	COMMUNITY MODE $F6 = 5I$ <u>During the opening:</u> The start commands don't have any effect. <u>During the closing:</u> The start commands stop the closing and begin the opening.	STEP-BY-STEP SETTING $F6 = A0$ and $F5 = 5I$ <u>During the opening:</u> The start commands stop the gate. <u>During the closing:</u> The start commands stop the gate.
Photocells Logic 	$F8 = 5I$ → STANDARD MODE <u>During the opening:</u> If the internal photocell is activated the control board stops the opening and starts the closing. After 3 seconds the closure is stopped and the control board state is stop-opening. The activation of the external photocell doesn't have any effect instead. <u>During the closing:</u> If the external photocell is activated the control board stops the closing and starts the opening. The activation of the internal photocell doesn't have any effect instead.		
		$F8 = A0$ → REVERSE MODE <u>During the opening:</u> While the internal photocell is activated the control board stops the opening. When the internal photocell is deactivated the control board continues the opening. The activation of the external photocell doesn't have any effect instead. <u>During the closing:</u> If the external photocell is activated the control board stops the closing and starts the opening. If the internal photocell is activated the control board stops the closing and waits for the opening. The opening starts only when the internal photocell is deactivated.	
Cold Winter 	The cold winter function is useful in countries with very cold winters. The motor is activated with the minimum power for $L1$ minutes out of 10 minutes to keep the control board box and the motor warm. When the motor is activated with the minimum power, the gate doesn't move. The function runs when the gate is completely open or in stand-by only. When $L1$ is set to 00 the function is disabled. $L1$ is settable from 00 to 10 .		
Recovery Loop 	$L2 = 5I$ → ENABLED $L2 = A0$ → DISABLED This function is useful to avoid motor lock due to gate inertia. This event may happen when the gate reaches the closing or opening limit switch without slowing down. The recovery loop works when a working cycle starts and the closing limit switch is inactive. In a recovery loop the standard working time is 1 second, the slowdown working time is 240 seconds and the obstacle detection sensor is disabled. The recovery loop ends when a opening or closing limit switch is activated. This function works only if $E5$, $E6$, $A2$ and $L2$ are enabled.		
Photocells Test 	$E1 = 5I$ → ENABLED $E1 = A0$ → DISABLED Each time the gate starts, the control board checks the photocells. If no errors are detected the motor can be started. Vice versa the motor cannot start and the control board display shows IE .		
Motor Thermal Test 	$E2 = 5I$ → ENABLED $E2 = A0$ → DISABLED Before starting a working cycle the motor is tested. When the display shows $9A$ the motor is in thermal protection. This test may fail if the motor is badly connected. When the motor is in thermal protection, the working cycle cannot be started.		

Erasing a remote key 	<p>Keep pressing A or B button until the display shows . After a few seconds the control board starts scanning for saved codes. Each code showed is a remote key identification number previously saved. To erase a displayed code, hold down button C until display turns off.</p>
Saving a remote key	<p>A remote key is configurable as: start , stop , pedestrian  or fast closure . Hold down or keep pressing A or B button on the control board until the display shows the chosen function , ,  or . After about one second, the display shows . Hold down an unsaved remote key. The display shows . To save push down the button C on the control board. After saving, the display shows the remote key identification number. The control board holds up to 99 codes. If the memory is full, the display shows  when trying to save the remote key.</p> <ul style="list-style-type: none"> <p>•  Start The start function begins a Standard Working Cycle : The motor works for a total time of  plus  seconds during the opening and the closing.</p> <p>•  Stop The stop function stops the gate.</p> <p>•  Pedestrian The pedestrian function begins a Pedestrian Working Cycle: The motor works for a total time of  seconds during the opening and closing. The slowdown phase is skipped during the opening and executed during the closing. The slowdown time is automatically managed by the control board during a pedestrian working cycle.</p> <p>•  Fast closure <i>During the opening:</i> once the external photocells have been activated, the gate starts closing after 5 seconds. <i>During the pause time</i> : once the external photocells have been activated, the gate starts closing.</p> <p style="text-align: center;">For safety reasons it is advisable to link this function to a remote key only when two pairs of external photocells are installed as shown in TYPICAL INSTALLATION (see page 3).</p>
Erasing all remote controls 	<p>Keep pressing A or B button until the display shows . After a few seconds the control board shows . To erase all saved codes, hold down button C until the display stops flashing  (YES).</p>

Each terminal block input is programmable by a configuration parameter. The configuration parameters are $E1$, $E2$, $E3$, $E4$, $E5$, $E6$ and $E7$. $E1$ configures the terminal block input 1, $E2$ configures the terminal block input 2 and so on.

<p>Input 1 Start - Open Only - Close Only</p> <p style="text-align: center;">$E1$</p>	<p>$E1 = n0 \rightarrow$ DISABLED $E1 = 00$ or $0P$ or $CL \rightarrow$ ENABLED</p> <p>The input 1 is configurable as one of the following functions: Disabled $n0$, Start 00, Open Only $0P$ or Close Only CL. The Start, Open Only and Close Only functions match a normally open contact. It is advisable to set $E1$ to $n0$, if the input 1 is not used. When the input 1 is enabled and activated, the display shows 00, $0P$ or CL.</p>
<p>Input 2 Stop</p> <p style="text-align: center;">$E2$</p>	<p>$E2 = n0 \rightarrow$ DISABLED $E2 = 5E \rightarrow$ ENABLED</p> <p>The input 2 is configurable as Disabled $n0$ or Stop $5E$. The Stop function matches a normally closed contact. It is always advisable to install an external stop switch. During the installation phase it may be useful to disable $E2$. When a normally closed switch is wired to the terminal block input 2, the $E2$ parameter is automatically set to $5E$ (Stop). When the Stop is enabled and activated, the display shows $5E$.</p>
<p>Input 3 External Photocell</p> <p style="text-align: center;">$E3$</p>	<p>$E3 = n0 \rightarrow$ DISABLED $E3 = EC \rightarrow$ ENABLED</p> <p>The input 3 is configurable as Disabled $n0$ or External Photocell EC. The External Photocell function matches a normally closed contact. It is always advisable to install the external photocell device. During the installation phase it may be useful to disable $E3$. When the photocell device is wired to the terminal block input 3, the $E3$ parameter is automatically set to EC (External Photocell). When the External Photocell is enabled and activated, the display shows EC.</p>
<p>Input 4 Internal Photocell</p> <p style="text-align: center;">$E4$</p>	<p>$E4 = n0 \rightarrow$ DISABLED $E4 = ER \rightarrow$ ENABLED</p> <p>The input 4 is configurable as Disabled $n0$ or Internal Photocell. The Internal Photocell function matches a normally closed contact. It is always advisable to install the internal photocell device. During the installation phase it may be useful to disable $E4$. When the photocell device is wired to the terminal block input 4, the $E4$ parameter is automatically set to ER (Internal Photocell). When the internal photocell is enabled and activated, the display shows ER.</p>
<p>Input 5: Closing Limit Switch N.C - Closing Limit Switch N.O.</p> <p style="text-align: center;">$E5$</p>	<p>$E5 = n0 \rightarrow$ DISABLED $E5 = FC$ or $LC \rightarrow$ ENABLED</p> <p>The input 5 is configurable as one of the following functions: Disabled $n0$, Closing limit switch N.C. FC or Closing limit switch N.O. LC. The Closing limit switch N.C. matches a normally closed contact. The Closing limit switch N.O. matches a normally open contact. If the input 5 is enabled and activated, the display shows FC or LC.</p>
<p>Input 6 Opening Limit Switch N.C - Opening Limit Switch N.O.</p> <p style="text-align: center;">$E6$</p>	<p>$E6 = n0 \rightarrow$ DISABLED $E6 = FR$ or $LR \rightarrow$ ENABLED</p> <p>The input 6 is configurable as one of the following functions: Disabled $n0$, Opening limit switch N.C. FR or Opening limit switch N.O. LR. The Opening limit switch N.C. matches a normally closed contact. The Opening limit switch N.O. matches a normally open contact. When the input 6 is enabled and activated, the display shows FR or LR.</p>
<p>Input 7 Pedestrian - Open Only - Close Only</p> <p style="text-align: center;">$E7$</p>	<p>$E7 = n0 \rightarrow$ DISABLED $E7 = PE$ or $0P$ or $CL \rightarrow$ ENABLED</p> <p>The input 7 is configurable as one of the following functions: Disabled $n0$, Pedestrian Start PE, Open Only $0P$ or Close Only CL. The Pedestrian Start, Open Only and Close Only functions match a normally open contact. It is advisable to set $E7$ to $n0$, if the input 7 is not used. When the input 7 is enabled activated, the display shows PE, $0P$ or CL.</p>

Default Restore <div style="text-align: center; border: 1px solid black; width: 40px; margin: 0 auto; padding: 2px;">d0</div>	<p>To restore the factory default setting, keep pressing button A or B until the display shows d0. After a few seconds the control board shows n0. To execute hold down button C until the display shows - -. The factory default has been set and the control board state is in stand by state. This function doesn't have any effect on radio programming.</p>								
Motor Working Time Programming <div style="text-align: center; border: 1px solid black; width: 40px; margin: 0 auto; padding: 2px;">P1</div>	<p>P1 is a semi-automatic procedure to acquire the working time parameters. The working time parameters are R1, R2 and F0. In other words, after this procedure the standard working time, the slowdown working time of the motor and the pause time are acquired by the control board. Before beginning this procedure, check that all safety devices are connected, the control board is in stand by state, and the sense of rotation of the motor is correct. To begin this procedure hold down or keep pressing button A or B until the control board display shows P1. After a few seconds the control board display shows - -. After pressing a start input, the procedure will start. This procedure is divided into 3 steps: R1, R2 and F0. In each step the linked parameter is programmed. During the whole programming procedure the obstacle detection sensor is disabled.</p> <table border="1" style="width: 100%; border-collapse: collapse; margin-top: 10px;"> <tr> <td style="width: 15%; text-align: center; vertical-align: middle;">P1 → - -</td> <td style="padding: 5px;"> <p>The control board is ready to start the motor working time programming. To go to R1 press any start input.</p> </td> </tr> <tr> <td style="width: 15%; text-align: center; vertical-align: middle;">R1</td> <td style="padding: 5px;"> <p>The standard working time of the motor (R1) is being programmed. The gate is opening. To change the programming phase:</p> <p>If opening limit switch is not installed (E6 = n0):</p> <ul style="list-style-type: none"> • To go to R2 press any start input. <p>If opening limit switch is installed (E6 = S1):</p> <ul style="list-style-type: none"> • To go to R2 press any start input. • To go to F0 wait until the gate reaches the opening limit switch. An extra time of 30 seconds will be added to R1. </td> </tr> <tr> <td style="width: 15%; text-align: center; vertical-align: middle;">R2</td> <td style="padding: 5px;"> <p>The slowdown working time of the motor (R2) is being programmed. The gate is slowing down. To change the programming phase:</p> <p>If opening limit switch is not installed (E6 = n0):</p> <ul style="list-style-type: none"> • To go to F0 press any start input. <p>If opening limit switch is installed (E6 = S1):</p> <ul style="list-style-type: none"> • To go to F0 wait until the gate reaches the opening limit switch. An extra time of 45 seconds will be added to R2. </td> </tr> <tr> <td style="width: 15%; text-align: center; vertical-align: middle;">F0</td> <td style="padding: 5px;"> <p>The pause time is being programmed (F0). The gate is stopped. The flashing lamp is on. After a few seconds the control board display shows the counting time. To finish the programming press any start input and wait until the gate is completely closed.</p> </td> </tr> </table>	P1 → - -	<p>The control board is ready to start the motor working time programming. To go to R1 press any start input.</p>	R1	<p>The standard working time of the motor (R1) is being programmed. The gate is opening. To change the programming phase:</p> <p>If opening limit switch is not installed (E6 = n0):</p> <ul style="list-style-type: none"> • To go to R2 press any start input. <p>If opening limit switch is installed (E6 = S1):</p> <ul style="list-style-type: none"> • To go to R2 press any start input. • To go to F0 wait until the gate reaches the opening limit switch. An extra time of 30 seconds will be added to R1. 	R2	<p>The slowdown working time of the motor (R2) is being programmed. The gate is slowing down. To change the programming phase:</p> <p>If opening limit switch is not installed (E6 = n0):</p> <ul style="list-style-type: none"> • To go to F0 press any start input. <p>If opening limit switch is installed (E6 = S1):</p> <ul style="list-style-type: none"> • To go to F0 wait until the gate reaches the opening limit switch. An extra time of 45 seconds will be added to R2. 	F0	<p>The pause time is being programmed (F0). The gate is stopped. The flashing lamp is on. After a few seconds the control board display shows the counting time. To finish the programming press any start input and wait until the gate is completely closed.</p>
P1 → - -	<p>The control board is ready to start the motor working time programming. To go to R1 press any start input.</p>								
R1	<p>The standard working time of the motor (R1) is being programmed. The gate is opening. To change the programming phase:</p> <p>If opening limit switch is not installed (E6 = n0):</p> <ul style="list-style-type: none"> • To go to R2 press any start input. <p>If opening limit switch is installed (E6 = S1):</p> <ul style="list-style-type: none"> • To go to R2 press any start input. • To go to F0 wait until the gate reaches the opening limit switch. An extra time of 30 seconds will be added to R1. 								
R2	<p>The slowdown working time of the motor (R2) is being programmed. The gate is slowing down. To change the programming phase:</p> <p>If opening limit switch is not installed (E6 = n0):</p> <ul style="list-style-type: none"> • To go to F0 press any start input. <p>If opening limit switch is installed (E6 = S1):</p> <ul style="list-style-type: none"> • To go to F0 wait until the gate reaches the opening limit switch. An extra time of 45 seconds will be added to R2. 								
F0	<p>The pause time is being programmed (F0). The gate is stopped. The flashing lamp is on. After a few seconds the control board display shows the counting time. To finish the programming press any start input and wait until the gate is completely closed.</p>								

DECLARATION OF COMPLIANCE

Manufacturer: **Quiko Italy**
Via Seccalegno,19
36040 Sossano (VI)
Italia

declares under his own responsibility that the product:
Control board **QK-CE220RL4**

complies with the main safety requirements issued by the following directives:

- ✓ Radio Sets - 1999/05/EC ;
- ✓ Low Voltage - 2006/95/EC ;
- ✓ Electromagnetic Compatibility - 2004/108/EC

and any revisions thereof, and complies with the provisions that implement said directives in the National Legislation of the Country of destination where the products are to be used.

Sossano, 10/11/2012

Il Legale Rappresentante
Luca Borinato





Quiko Italy

Via Seccalegno, 19
36040 Sossano (VI) - Italy

Tel. +39 0444 785513

Fax +39 0444 782371

info@quiko.biz

www.quikoitaly.com



*The Manufacturer can technically improve
the quality of its products without
any prior notice.*

www.quikoitaly.com



guida all'installazione

QK-CE220RL4

SCHEDA DI COMANDO PER 1 MOTORE MONOFASE 230V ac

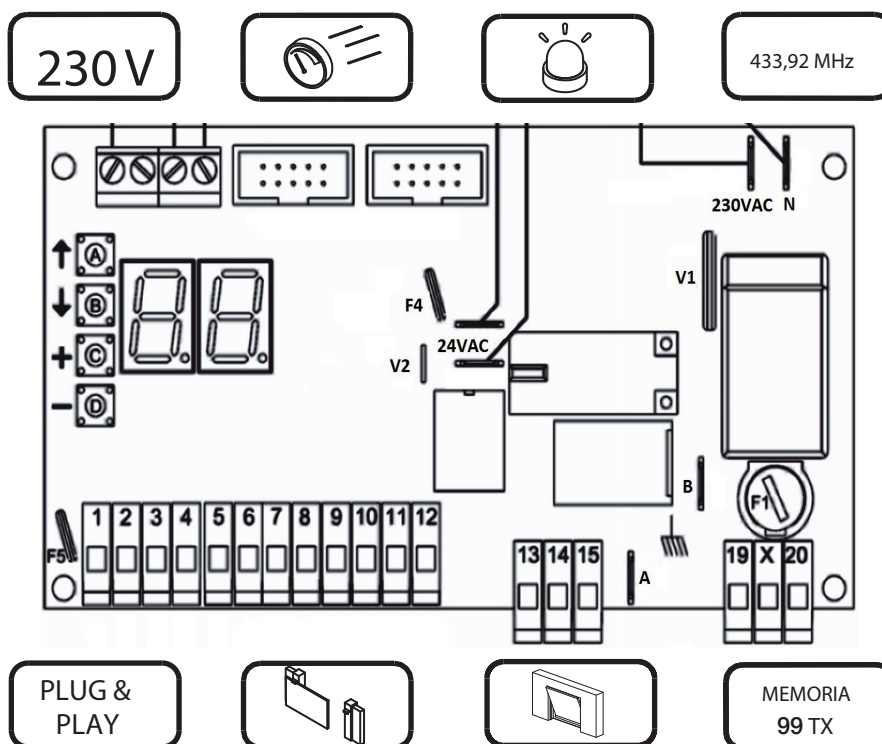

qui > **lo**®
opening solutions

INSERIRE NEL LAMPEGGIATORE O NEL CONTENITORE ANTENNA PER AUMENTARE LA PORTATA DELLA RADIO (pag 3).

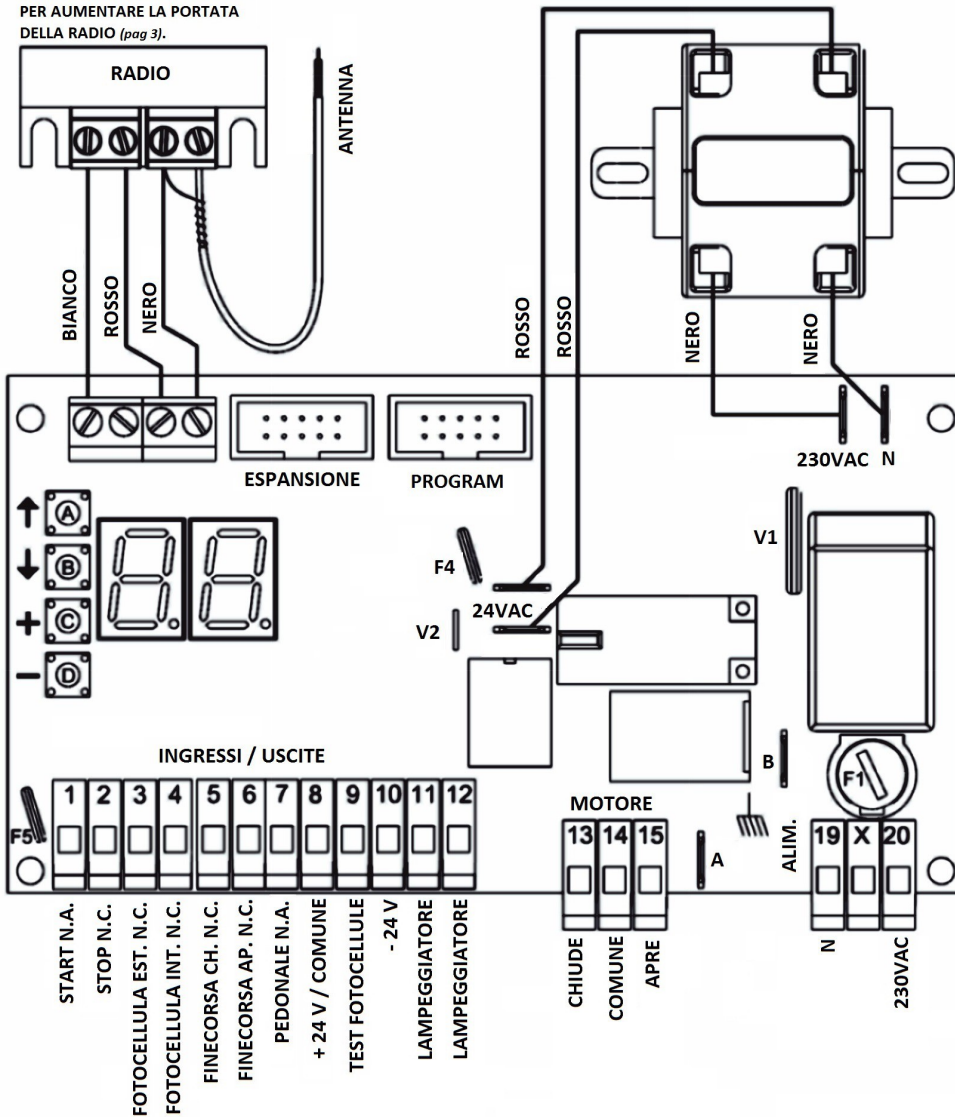

COMPONENTI

A	Tasto A
B	Tasto B
C	Tasto C
D	Tasto D
F1	Fusibile 250 VAC 5A
F4	Fusibile ripristinabile 24V 1.6A
F5	Fusibile ripristinabile 24V 0.6A
A B	Terminale di terra
CN	Connettore elettroserratura
V1	Varistore primario
V2	Varistore secondario
da 1 a 20	Morsettiera

ATTENZIONE

FUSIBILE RIPRISTINABILE

DOPO UN CORTOCIRCUITO



SPEGNERE LA CENTRALE E RIMUOVERE IL CORTOCIRCUITO. PRIMA DI ALIMENTARE NUOVAMENTE LA CENTRALE ASPETTARE ALMENO 60 SECONDI.

CONNESSIONE INGRESSI

FOTOCELLULA ESTERNA	ALIMENTAZIONE 24 VDC		TIPO	PIN	PARAMETRO
TRASMETTITORE	8 +	10 -	N.C.	X X	E 3
RICEVITORE				3 8	

FOTOCELLULA INTERNA	ALIMENTAZIONE 24 VDC		TIPO	PIN	PARAMETRO
TRASMETTITORE	8 +	10 -	N.C.	X X	E 4
RICEVITORE				4 8	

ALTRI INGRESSI	TIPO	PIN	PARAMETRO
START – SOLO APRI – SOLO CHIUDI	N.A.	1 8	E 1
PEDONALE – SOLO APRI – SOLO CHIUDI	N.A.	7 8	E 7
STOP	N.C.	2 8	E 2
FINECORSO CHIUSURA	N.C.	5 8	E 5
FINECORSO APERTURA	N.C.	6 8	E 6

N.C. Normalmente Chiuso
N.A. Normalmente Aperto

CONNESSIONE USCITE

MOTORE	CHIUDE	COMUNE	APRE
Motore	13	14	15

LAMPEGGIATORE 24V 20W	
11	12

ALIMENTATORE 24V 150mA	
8 +	10 -

CONNESSIONE ALIMENTAZIONE

INGRESSO 230 VAC	
19	20

IMPOSTAZIONI MOTORE

DISPLAY	DEFAULT	<input type="checkbox"/> C MAX	<input type="checkbox"/> D MIN	DESCRIZIONE
A1	30 sec	99 sec	00 sec	Tempo di lavoro normale.
A2	10 sec	99 sec	00 sec	Tempo di lavoro in rallentamento.
A3	0.1 sec	1.5 sec	0.1 sec	Tempo di avvio.
A5	7	10	1	Forza normale.
A6	8	10	1	Forza rallentamento.
A7	NO	99 - NO	0	Soglia del sensore di sforzo in modalità normale. Durante il tempo di lavoro normale il display mostra lo sforzo del motore.
A8	NO	99 - NO	0	Soglia del sensore di sforzo in modalità rallentamento. Durante il tempo di lavoro in rallentamento il display mostra lo sforzo del motore.

FUNZIONI DI CORTESIA

DISPLAY	DISPLAY	<input type="checkbox"/> C	DESCRIZIONE
d0	n0	Imposta	Per ripristinare il default mantenere premuto il tasto <input type="checkbox"/> c finché il display non mostra 00 .
P1	- -	X	Quando un comando di start è ricevuto la centrale avvia una procedura d'acquisizione dei tempi di manovra.

FUNZIONI

DISPLAY	DEFAULT	<input type="checkbox"/> C MAX	<input type="checkbox"/> D MIN	DESCRIZIONE
F0	10 sec	99 sec	00 sec	Tempo di pausa. Per disabilitare tenere premuto il tasto <input type="checkbox"/> C finché il display non mostra 5E .
F1	7 sec	A1 sec	00 sec	Tempo di lavoro pedonale.
F2	0.0 sec	1.0 sec	0.0 sec	Colpo di chiusura.
F3	0.0 sec	5.0 sec	00 sec	Tempo di lampeggio.
F4	NO (OFF)	SI (ON)	NO (OFF)	Colpo d'ariete.
F5	NO (OFF)	SI (ON)	NO (OFF)	Passo-Passo.
F6	NO (OFF)	SI (ON)	NO (OFF)	Condominiale.
F8	SI	SI	NO	Logica fotocellule: 51 → Logica Scorrevole n0 → Logica Battente
L1	00	10 min	00 min	Funzione inverno freddo. Può essere utile in paesi con inverno estremamente freddo.
L2	NO (OFF)	SI (ON)	NO (OFF)	Funzione ciclo di ripristino. Questa funzione è utile per evitare problemi di blocco del motore dovuti all'inerzia del cancello.
E1	NO (OFF)	SI (ON)	NO (OFF)	Test fotocellule.
E2	SI (ON)	SI (ON)	NO (OFF)	Test motore in termico.

IMPOSTAZIONI INGRESSI

DISPLAY	DEFAULT	<input type="checkbox"/> C	<input type="checkbox"/> D	DESCRIZIONE
E1	00	↓	↑	n0 = Disabilitato. 00 = Start N.A. 0P = Solo Apri N.A. CL = Solo Chiudi N.A.
E2	n0	↓	↑	n0 = Disabilitato. 5E = Stop N.C.
E3	n0	↓	↑	n0 = Disabilitato. EC = Fotocellula esterna N.C.
E4	n0	↓	↑	n0 = Disabilitato. ER = Fotocellula interna N.C.
E5	FC	↓	↑	n0 = Disabilitato. FC = Finecorsa Chiusura N.C. LC = Finecorsa Chiusura N.A.
E6	FR	↓	↑	n0 = Disabilitato. FR = Finecorsa Apertura N.C. LR = Finecorsa Apertura N.A.
E7	PE	↓	↑	n0 = Disabilitato. PE = Start Pedonale N.A. 0P = Solo Apri N.A. CL = Solo Chiudi N.A.

N.A. → Normalmente Aperto **N.C.** → Normalmente Chiuso

FUNZIONI RADIO

DISPLAY	DISPLAY	<input type="checkbox"/> C	DESCRIZIONE
r0	1...2...	Elimina	Cancella il codice mostrato: Quando il display mostra il codice identificativo del telecomando da cancellare mantenere premuto il tasto <input type="checkbox"/> c finché il display non si spegne: 00 .
r1	00	Salva	Per salvare un telecomando: Mantenere premuto il tasto del telecomando. I display mostrano 00 , premere il tasto <input type="checkbox"/> c della centrale. La centrale memorizza 99 codici. r1 → Start r2 → Stop r3 → Start Pedonale r4 → Chiusura rapida
r2	00	Salva	
r3	00	Salva	
r4	00	Salva	
r5	n0	Elimina	Elimina tutti i codici: Mantenere premuto il tasto <input type="checkbox"/> c finché il display non mostrano 51 fisso.

SEGNALAZIONI

5E	Stop.
FH	Fotocellula interna + Fotocellula esterna.
EC	Fotocellula esterna.
ER	Fotocellula interna.
0P	Solo Apri.
CL	Solo Chiudi.
IH	Finecorsa d'apertura + Finecorsa di chiusura. Normalmente Chiuso.
FR	Finecorsa d'apertura. Normalmente Chiuso.
FC	Finecorsa di chiusura. Normalmente Chiuso.
LR	Finecorsa di apertura. Normalmente Aperto.
LC	Finecorsa di chiusura. Normalmente Aperto.
L2	Funzione ciclo di ripristino attiva.
- -	Tasto del telecomando premuto.
1E	Errore Test Fotocellule.
7R	Rilevazione ostacolo motore durante il tempo di lavoro normale.
8R	Rilevazione ostacolo motore durante il tempo di lavoro in rallentamento.
9R	Motore in protezione termica.
FF	Memoria radio piena.

TASTI

- A Scorre il menù da **A1** a **P2**
- B Scorre il menù da **P2** a **A1**
- C Incrementa il valore o imposta **51** (Abilita).
- D Decrementa il valore o imposta **n0** (Disabilita).

INSTALLAZIONE TIPO

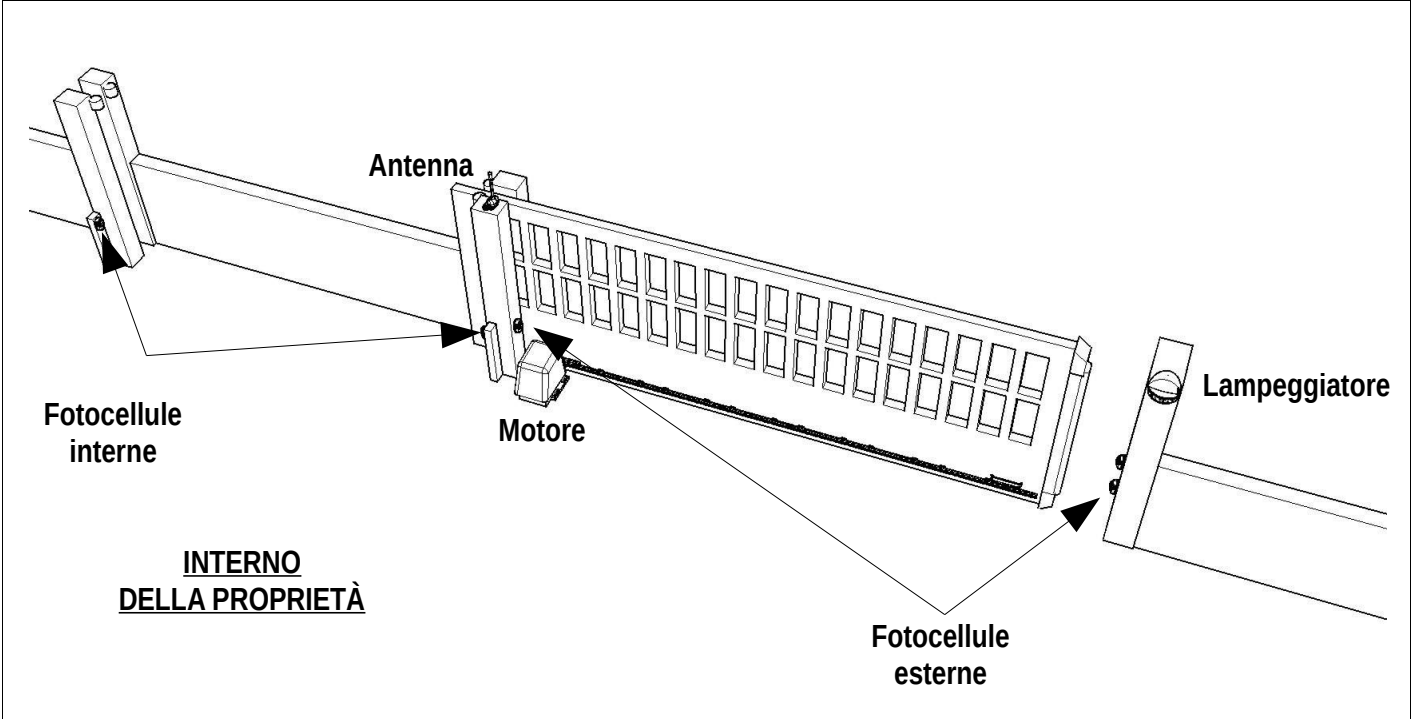

INSTALLAZIONE MODULO RADIO

**ALL'INTERNO DEL CONTENITORE ANTENNA
OPTIONAL QK-AN433_V4**

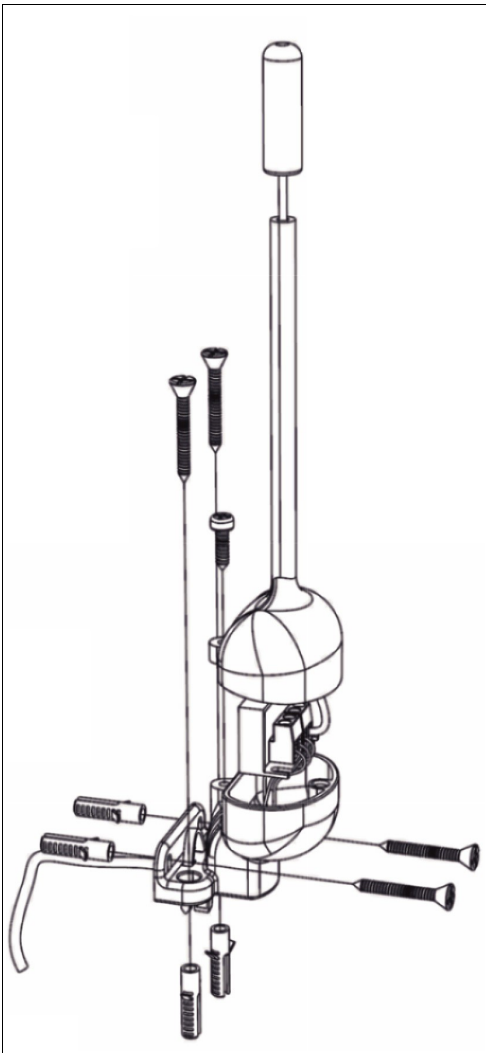

ALL'INTERNO DEL LAMPEGGIATORE

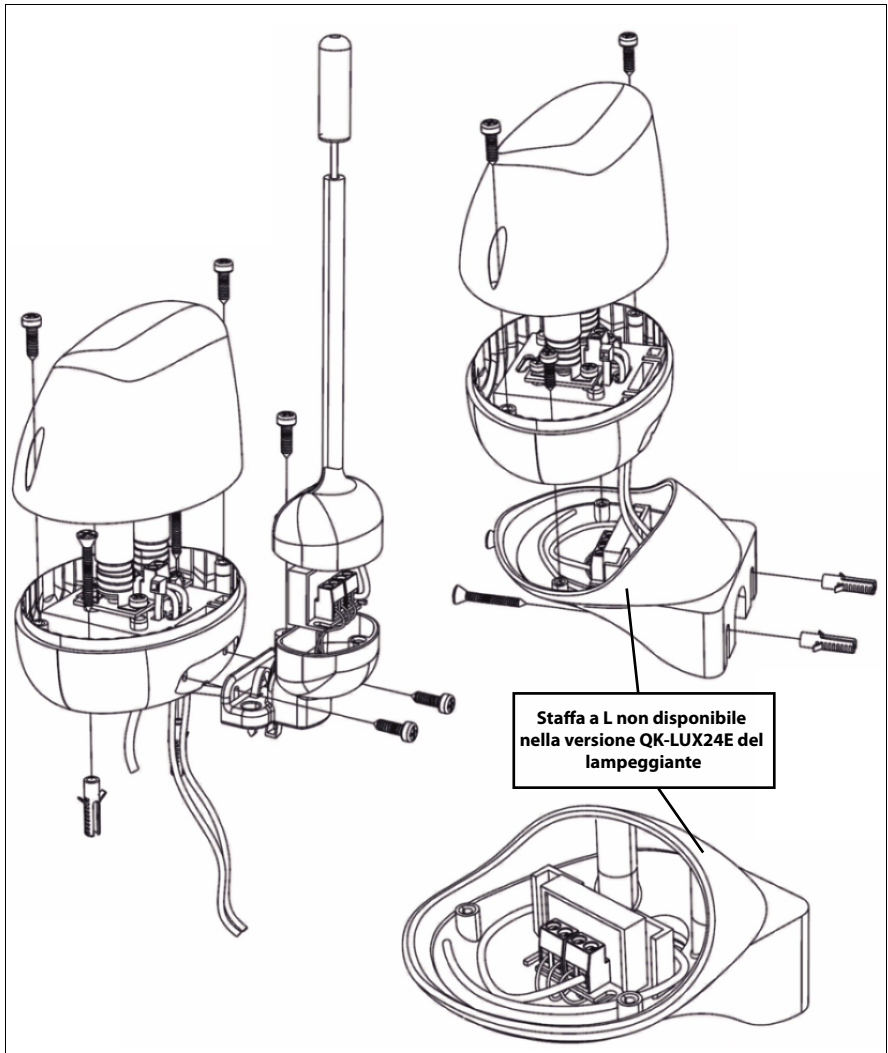

COLLEGAMENTI INGRESSI/USCITE

ALIMENTAZIONE 230 VAC

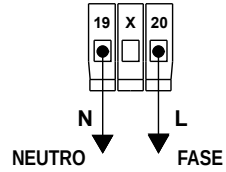

START PEDONALE

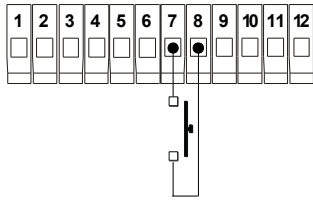

START

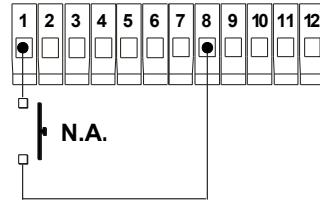

STOP

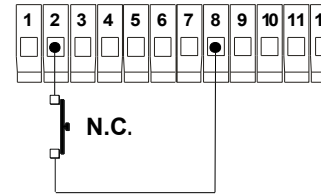

FINE CORSA CHIUSURA

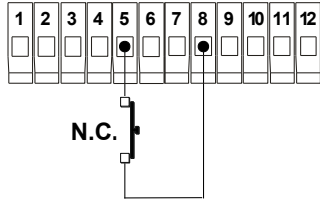

FINE CORSA APERTURA

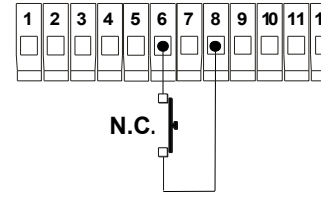

MOTORE 230 VAC

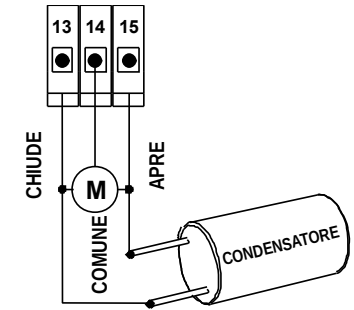

LAMPEGGIATORE

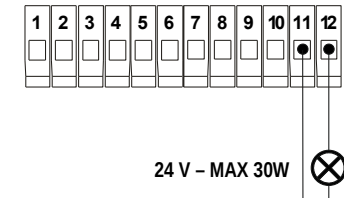

24V DC - 150mA

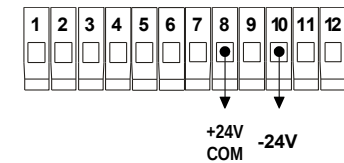

FOTOCELLE INTERNE

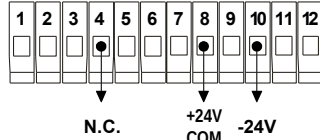

FOTOCELLE ESTERNE

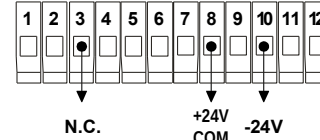

	FOTOCELLE INTERNE	FOTOCELLE ESTERNE
RICEVITORE FOTOCELLE		
(4.A) TRASMETTITORE FOTOCELLE SENZA FUNZIONE DI TEST		
(4.B) TRASMETTITORE FOTOCELLE CON FUNZIONE DI TEST		
(4.C) DISABILITAZIONE HARDWARE		
(4.D) DISABILITAZIONE SOFTWARE	Impostare E4 a 00	Impostare E3 a 00

Il parametro **E1** abilita (**51**) o disabilita (**00**) il test delle fotocelle. Le impostazioni **(4.A)** e **(4.C)** richiedono **E1** impostato a **00**.

Stand By	Il cancello è completamente chiuso e i dispositivi di sicurezza sono disattivati. La centrale di controllo è pronta per iniziare un ciclo di lavoro. In questo stato il lampeggiatore è spento.
Apertura	Il cancello si sta aprendo e il lampeggiatore lampeggia velocemente.
Pausa	Durante la Pausa il motore è fermo ed il lampeggiatore è acceso fisso. Dopo il tempo di pausa $F10$ il cancello inizia la chiusura .
Chiusura	Il cancello si sta chiudendo ed il lampeggiatore lampeggia lento.
Stop Apertura	Il cancello è stato stoppato mentre si stava aprendo. Un nuovo comando di start avvia la fase di chiusura. In questo stato il lampeggiatore è spento.
Stop Chiusura	Il cancello è stato stoppato mentre si stava chiudendo. Un nuovo comando di start avvia la fase di apertura. In questo stato il lampeggiatore è spento.
Tipi di ingresso	Gli ingressi possono essere esterni o da telecomando. Gli ingressi esterni sono tutti i dispositivi che vengono collegati alla morsettiera: fotocellule, contatti normalmente chiusi o aperti. Ogni terminale della morsettiera è associato ad una funzione. Le funzioni di sicurezza sono associate a contatti normalmente chiusi. Le altre funzioni a contatti normalmente aperti. Le funzioni di sicurezza sono: Stop, Fotocellule Interne, Fotocellule Esterne, Finecorsa Chiusura N.C., Finecorsa Apertura N.C. Le altre invece: Start, Start Pedonale, Solo Apri, Solo Chiudi, Fine Corsa Chiusura N.A., Fine Corsa Apertura N.A. Si può scegliere la funzione del morsetto attraverso la programmazione dei parametri: $E1$, $E2$, $E3$, $E4$, $E5$, $E6$ e $E7$. Gli ingressi da telecomando possono avere le seguenti funzioni: Start, Stop, Pedonale e Chiusura Rapida . I parametri che gestiscono l'associazione di queste funzioni ad un telecomando sono: $r1$, $r2$, $r3$ e $r4$.
Ingresso attivato	Un ingresso è attivato quando il suo stato cambia dal suo valore standard. Ad esempio una fotocellula è considerata attiva quando il fascio infrarosso tra il trasmettitore e il ricevitore è interrotto, oppure un generico selettore a chiave è attivato quando la chiave viene girata. Tutte queste azioni sono riconosciute dalla centrale di controllo che mostra il cambiamento sul display. Quando più ingressi sono attivati contemporaneamente la centrale di controllo mostra quello a priorità più alta. La priorità dalla più alta alla più bassa è la seguente: Stop $S1$, Fotocellule Esterne e Fotocellule Interne FH , EL Fotocellule Esterne , ER Fotocellule Interne , Start $G0$, Pedonale PE , Solo Apri $0P$, Solo Chiudi CL , Finecorsa Chiusura e Finecorsa Apertura TH , Finecorsa Chiusura N.C. FC , Finecorsa Apertura N.C. FA , Finecorsa Chiusura N.A. LC , Finecorsa Apertura N.A. LA .
Comandi di start	I comandi di start sono: Start, Pedonale e Chiusura Rapida . I comandi di start sono in grado di avviare un ciclo di lavoro. Il funzionamento dei comandi di start dipende dalla programmazione dei parametri $F5$ ed $F6$. Per maggiori informazioni guardare la descrizione di $F5$ ed $F6$. Per conoscere il funzionamento della Chiusura Rapida guardare la descrizione di $r4$.
Dispositivi di sicurezza	I dispositivi di sicurezza sono: lo Stop , le Fotocellule Interne e le Fotocellule Esterne . I comandi di stop fermano sempre il cancello. Invece il funzionamento delle fotocellule dipende dal parametro $F8$. Per maggiori informazioni guardare la descrizione di $F8$.
Ciclo di lavoro standard	Un ciclo di lavoro standard è avviato quando la centrale è in stato di stand by e un comando di start viene ricevuto: il motore lavora per un tempo totale di $R1$ più $R2$ secondi durante l'apertura e la chiusura. Durante un ciclo di lavoro standard tutti i comandi di start pedonale e chiusura rapida sono considerati come start. Il funzionamento di un ciclo di lavoro standard può essere modificato attraverso la programmazione dei parametri.
Ciclo di lavoro pedonale	Un ciclo di lavoro pedonale è avviato quando la centrale è in stato di stand by e un comando di start pedonale viene ricevuto. Il motore lavora per $F11$ secondi durante l'apertura e la chiusura. La fase di rallentamento è saltata durante l'apertura ed eseguita durante la chiusura. Il tempo di rallentamento è gestito automaticamente dalla centrale. Durante un ciclo di lavoro pedonale tutti i comandi di start sono considerati come start pedonali .

<p>Tempo normale</p> <p>R1</p>	<p>Il motore lavora per R1 secondi. Dopo questo tempo inizia la fase di rallentamento che dura R2 secondi. Questo avviene sia in apertura che in chiusura.</p> <p>R1 è impostabile da 00 a 99 secondi.</p>
<p>Tempo rallentamento</p> <p>R2</p>	<p>R2 è impostabile da 00 a 99 secondi.</p>
<p>Tempo di avvio</p> <p>R3</p>	<p>R3 è il tempo di avvio del motore. Durante questo tempo la forza del motore cresce costantemente fino a raggiungere il valore massimo. Durante questa fase il sensore ostacoli è disabilitato. Ogniquale volta il motore parte i primi R3 secondi sono considerati come tempo d'avvio.</p> <p>R3 è impostabile da 0.1 a 1.5 secondi.</p>
<p>Forza normale</p> <p>R5</p>	<p>R5 è la forza del motore durante il tempo normale di lavoro parametro R1.</p> <p>R5 è impostabile da 00 a 10</p>
<p>Forza rallentamento</p> <p>R6</p>	<p>R6 è la forza del motore durante il tempo di rallentamento parametro R2.</p> <p>R6 è impostabile da 00 a 10</p>
<p>Soglia di ostacolo normale</p> <p>R7</p>	<p>Durante il tempo normale R1 se lo sforzo del motore è maggiore della soglia di ostacolo normale R7 allora:</p> <p>La centrale prende una decisione in accordo con la programmazione effettuata come descritto in OPERATIVITÀ DEL SENSORE (pagina 7).</p> <p>Durante il tempo di lavoro normale R1, il display mostra il valore dello sforzo del motore. 00 è il valore minimo, 99 quello massimo. Il valore massimo dipende dal motore e può essere minore di 99. Per disabilitare il sensore ostacoli in modalità normale impostare R7 = 00. Per impostare R7 = 00 premere ripetutamente o mantenere premuto il tasto C. R7 è impostabile da 00 a 99. Dopo 99 il display mostra 00.</p>
<p>Soglia di ostacolo in rallentamento</p> <p>R8</p>	<p>Durante il tempo di rallentamento R2 se lo sforzo del motore è maggiore della soglia di ostacolo rallentamento R8 allora:</p> <p>La centrale prende una decisione in accordo con la programmazione effettuata come descritto in OPERATIVITÀ DEL SENSORE (pagina 7).</p> <p>Durante il tempo di rallentamento R2, il display mostra il valore dello sforzo del motore. 00 è il valore minimo, 99 quello massimo. Il valore massimo dipende dal motore e può essere minore di 99. Per disabilitare il sensore ostacoli in modalità normale impostare R7 = 00. Per impostare R7 = 00 premere ripetutamente o mantenere premuto il tasto C. R7 è impostabile da 00 a 99. Dopo 99 il display mostra 00.</p>

Ci sono 2 modalità operative RILEVAZIONE OSTACOLI e FINECORSA come descritto nella tabella seguente:

RILEVAZIONE OSTACOLI	FINE CORSA
In questa modalità operativa il motore inverte la direzione. Se stava chiudendo apre completamente. Se stava aprendo, chiude per 2 secondi dopo di che va in stop. Un comando di start rinnova la chiusura. La modalità rilevazione d'ostacoli è attiva una sola volta per ciclo di lavoro. Tutte le altre volte il sensore funziona nella modalità fine corsa.	In questa modalità il sensore finisce la fase attuale e inizia la successiva: da apertura a pausa, da chiusura a stand by.

La modalità operativa dipende dalla fase di lavoro e dalla programmazione dei parametri. Le fasi di lavoro sono: apertura, apertura rallentamento, chiusura, chiusura rallentamento. I parametri d'interesse sono: $R2$, $R7$, $R8$, $E5$, $E6$.

- Se $R7$ è impostato a $n0$ il sensore è disabilitato durante il tempo normale ($R1$). Questo significa che il sensore non funziona in nessuna modalità operativa durante il tempo normale ($R1$).
- Se $R8$ è impostato a $n0$ oppure $R2$ è uguale a 00 il sensore è disabilitato durante il tempo di rallentamento ($R2$). Questo significa che il sensore non funziona in nessuna modalità operativa durante il rallentamento ($R2$).
- Se gli ingressi di finecorsa sono installati ($E5 = 51$ e $E6 = 51$): il sensore funziona nella modalità RILEVAZIONE OSTACOLI.
- Se il fine corsa di apertura non è installato ($E6 = n0$) e l'apertura è in corso: il sensore funziona nella modalità RILEVAZIONE OSTACOLI durante il tempo di lavoro normale ($R1$). Durante il tempo di rallentamento ($R2$) il sensore funziona nella modalità FINE CORSA.
- Se il fine corsa di apertura non è installato ($E6 = n0$) e il tempo di rallentamento è disabilitato ($R2 = 00$): il sensore funziona nella modalità FINE CORSA durante l'apertura.
- Se il fine corsa di chiusura non è installato e la chiusura è in corso ($E5 = n0$): il sensore funziona nella modalità RILEVAZIONE OSTACOLI durante il tempo normale ($R1$). Durante il rallentamento ($R2$) il sensore funziona in modalità FINE CORSA.
- Se il fine corsa di chiusura non è installato ($E5 = n0$) e la fase di rallentamento è disabilitata ($R2 = 00$): il sensore funziona nella modalità operativa FINE CORSA durante la chiusura.
- Se entrambi i finecorsa non sono installati ($E5 = n0$ e $E6 = n0$): il sensore funziona nella modalità RILEVAZIONE OSTACOLI durante il tempo normale ($R1$). Durante il tempo di rallentamento ($R2$) il sensore funziona nella modalità RILEVAZIONE OSTACOLI.
- Se entrambi i fine corsa non sono installati ($E5 = n0$ e $E6 = n0$) e la fase di rallentamento è disabilitata ($R2 = 00$): il sensore funziona nella modalità FINE CORSA.





























































































OPERATIVITÀ FASE DI LAVORO	RILEVAZIONE OSTACOLI	FINE CORSA	DISABILITATO
Apertura	$E6 = 51$ o $E6 = n0$ e $R2$ ABILITATO	$E6 = n0$ e $R2 = 00$	$R7 = n0$
Apertura rallentamento	$E6 = 51$	$E6 = n0$	$R8 = n0$ o $R2 = 00$
Chiusura	$E5 = 51$ o $E5 = n0$ e $R2$ ABILITATO	$E5 = n0$ e $R2 = 00$	$R7 = n0$
Chiusura rallentamento	$E5 = 51$	$E5 = n0$	$R8 = n0$ o $R2 = 00$

Tempo Pausa	Dopo l' apertura la centrale entra in pausa per $F0$ secondi dopo di che avvia la fase di chiusura . Impostando $F0$ a $S4$, la centrale al termine della apertura pone il cancello in stato di stop di apertura . Per impostare $S4$ premere ripetutamente o mantenere premuto il tasto C finché il display non mostra $S4$. $F0$ è impostabile da 00 a 99. Dopo 99 i display mostrano $S4$.		
Tempo Pedonale	È il tempo di lavoro del motore durante un ciclo di lavoro pedonale . Durante l'apertura la fase di rallentamento è sempre saltata. In chiusura il rallentamento viene eseguito ed è gestito automaticamente dalla centrale di controllo. $F1$ è impostabile da 00 a $R1$ secondi.		
Colpo di chiusura	Quando il cancello si sta chiudendo e il rallentamento è finito, un impulso di chiusura viene eseguito dal motore. Tale impulso dura $F2$ secondi. Durante questo tempo il sensore di sforzo è disabilitato. $F2$ è impostabile da 0.0 a 1.0 secondi.		
Tempo di lampeggio	Prima che il motore si attivi, il lampeggiatore segnala la fase in avvio accendendosi e spegnendo ad intermittenza per $F3$ secondi. $F3$ è impostabile da 0.0 a 5.0 secondi.		
Colpo d'ariete	$F4 = S1 \rightarrow$ ABILITATO $F4 = n0 \rightarrow$ DISABILITATO Prima dell'apertura il motore chiude per 0.5 secondi. Durante questo tempo la forza del motore è massima e il sensore ostacoli è disabilitato.		
Funzionalità Comandi di start	STANDARD $F5 = n0$ e $F5 = n0$ <i>Durante l'apertura:</i> i comandi di start bloccano l'apertura. <i>Durante la chiusura:</i> i comandi di start bloccano la chiusura e avviano l'apertura.	CONDOMINIALE $F5 = S1$ <i>Durante l'apertura:</i> i comandi di start non hanno effetto. <i>Durante la chiusura:</i> i comandi di start bloccano la chiusura e avviano l'apertura.	PASSO-PASSO $F5 = n0$ e $F5 = S1$ <i>Durante l'apertura:</i> i comandi di start bloccano l'apertura. <i>Durante la chiusura:</i> i comandi di start bloccano la chiusura.
Logica delle fotocellule	$F8 = S1 \rightarrow$ LOGICA SCORREVOLE <i>Durante l'apertura:</i> Se le fotocellule interne sono attivate la centrale blocca l'apertura e avvia la chiusura. Dopo 3 secondi la chiusura è bloccata. Un nuovo comando di start è in grado di riavviare la chiusura. L'attivazione delle fotocellule esterne non ha nessun effetto. <i>Durante la chiusura:</i> Se le fotocellule esterne sono attivate la centrale blocca la chiusura e avvia l'apertura. L'attivazione delle fotocellule interne non ha effetto.		$F8 = n0 \rightarrow$ LOGICA BATTENTE <i>Durante l'apertura:</i> Finché le fotocellule interne sono attivate la centrale sospende l'apertura. Quando le fotocellule vengono disattivate l'apertura riprende. L'attivazione delle fotocellule esterne non ha effetto. <i>Durante la chiusura:</i> Se le fotocellule esterne sono attivate la centrale blocca la chiusura e avvia l'apertura. Se le fotocellule interne vengono attivate: la chiusura viene bloccata. La centrale attende che le fotocellule interne tornino non attive per avviare l'apertura.
Inverno Freddo	La funzione inverno freddo è utile nei paesi con un inverno estremamente freddo. Il motore è riscaldato (acceso alla minima potenza) per $L1$ minuti su 10. Il cancello non si muove mentre il motore ed il contenitore della centrale sono riscaldati. Ad esempio impostando $L1 = 03$ il motore è riscaldato per 3 minuti e rimarranno spenti per 7. È consigliabile disattivare questa funzione durante la stagione estiva. Questa funzione è impostabile da 00 a 10.		
Ciclo di ripristino	$L2 = S1 \rightarrow$ ABILITATO $L2 = n0 \rightarrow$ DISABILITATO Questa funzione è utile per evitare il blocco del motore dovuto all'inerzia del cancello. Questo evento può verificarsi quando il cancello raggiunge il finecorsa di apertura o chiusura senza rallentare. Verrà eseguito un ciclo di ripristino quando inizia un ciclo di lavoro e il finecorsa di chiusura è inattivo. Durante un ciclo di ripristino il tempo di lavoro normale è 1 secondo, il tempo di rallentamento è 240 secondi e il sensore ostacoli è disabilitato. Questa modalità termina quando il finecorsa di apertura o di chiusura è rilevato. Questa funzione può essere abilitata solo se: $E5$, $E6$, $R2$ e $L2$ sono abilitati.		
Test Fotocellule	$E1 = S1 \rightarrow$ ABILITATO $E1 = n0 \rightarrow$ DISABILITATO Prima di ogni manovra, la centrale controlla la presenza delle fotocellule. Se nessun errore viene determinato, il motore può essere avviato. In caso contrario il motore non viene avviato ed il display mostra $I1$.		
Test Motore	$E2 = S1 \rightarrow$ ABILITATO $E2 = n0 \rightarrow$ DISABILITATO Prima di ogni manovra, la centrale controlla lo stato termico del motore. Se il test fallisce il motore non può essere attivato e il display mostra $G2$. Questo test fallisce anche in caso di errata connessione.		

<p>Cancellare un telecomando</p> <p style="text-align: center;">r 0</p>	<p>Premere ripetutamente o mantenere premuto il tasto A o B finché il display non mostra r 0. Dopo un secondo, la centrale mostra in successione i codici dei telecomandi salvati. Ogni codice è rappresentato da un numero d'identificazione. Per cancellare il codice mostrato mantenere premuto il tasto C finché il display non si spegne.</p>
<p>Salvare un telecomando</p> <p>r 1 START</p> <p>r 2 STOP</p> <p>r 3 PEDONALE</p> <p>r 4 CHIUSURA RAPIDA</p>	<p>E' possibile associare ad un tasto del telecomando una di queste funzioni: start r 1, stop r 2, pedonale r 3 o chiusura rapida r 4. Per far questo premere ripetutamente o mantenere premuto il tasto A o B finché il display non mostra l'indicazione della funzione che si vuole associare al trasmettitore. Dopo circa un secondo sul display viene visualizzato E -. Mantenere premuto il tasto del telecomando da memorizzare, i display mostreranno E -, premere il tasto C della centrale per salvare. Dopo il salvataggio se il tasto del telecomando salvato viene premuto e una delle funzioni r 1, r 2, r 3 o r 4 è selezionata allora i display visualizzano il numero di identificazione del telecomando. La centrale memorizza 99 codici. Se la memoria è piena i display visualizzeranno F F al momento del salvataggio.</p> <p>r 1 funzione di start La funzione di start avvia un ciclo di lavoro standard: Il motore lavora per un tempo totale di R 1 più R 2 secondi durante l'apertura e la chiusura.</p> <p>r 2 funzione di stop La funzione di stop ferma il cancello.</p> <p>r 3 funzione di pedonale La funzione di pedonale avvia un ciclo di lavoro pedonale: il motore lavora per F 1 secondi durante l'apertura e la chiusura. La fase di rallentamento è saltata durante l'apertura ed eseguita durante la chiusura. Il tempo di rallentamento è gestito automaticamente dalla centrale.</p> <p>r 4 funzione di chiusura rapida <u>Durante l'apertura:</u> Se le fotocellule esterne sono state attivate, il motore inizia a chiudersi dopo 5 secondi. <u>Durante il tempo di pausa F 0:</u> Se le fotocellule esterne sono state attivate, il motore inizia a chiudersi.</p> <p>Per ragioni di sicurezza usare questa funzione solo quando due coppie di fotocellule esterne sono state installate come mostrato in INSTALLAZIONE TIPO (pagina 3).</p>
<p>Cancellazione totale</p> <p style="text-align: center;">r 5</p>	<p>Premere ripetutamente o mantenere premuto il tasto A o B finché il display non mostra r 5. Dopo un secondo sul display viene visualizzato r 0. Per cancellare tutti i codici salvati, mantenere premuto il tasto C finché i display non mostrano S 1 fisso.</p>

Ogni ingresso della morsettieria è programmabile tramite un parametro di configurazione. I parametri di configurazione sono: **E1**, **E2**, **E3**, **E4**, **E5**, **E6** e **E7**. **E1** configura l'ingresso 1, **E2** configura l'ingresso 2 e così via.

<p>Ingresso 1 Start – Solo Apri – Solo Chiudi</p> <p>E1</p>	<p>E1 = n0 → DISABILITATO E1 = 00 or 0P or CL → ABILITATO</p> <p>L'ingresso 1 è configurabile con queste funzioni: Disabilitato n0, Start 00, Solo Apri 0P o Solo Chiudi CL. Le funzioni Start, Solo Apri e Solo Chiudi sono associate a contatti normalmente aperti. Se l'ingresso 1 non viene usato è consigliabile impostare E1 = n0. Se l'ingresso 1 è abilitato e attivo sui display appare: 00, 0P o CL.</p>
<p>Ingresso 2 Stop</p> <p>E2</p>	<p>E2 = n0 → DISABILITATO E2 = 5E → ABILITATO</p> <p>L'ingresso 2 è configurabile con queste funzioni: Disabilitato n0 o Stop 5E. La funzione di Stop è associata ad un contatto normalmente chiuso. Durante la fase di installazione può essere utile disabilitare l'ingresso 2. Quando un contatto normalmente chiuso è collegato all'ingresso 2 la centrale lo rileva e imposta E2 = 5E(Stop). Se l'ingresso 2 è abilitato e attivo sui display appare: 5E.</p>
<p>Ingresso 3 Fotocellula Chiusura</p> <p>E3</p>	<p>E3 = n0 → DISABILITATO E3 = EE → ABILITATO</p> <p>L'ingresso 3 è configurabile con queste funzioni: Disabilitato n0 o Fotocellula Chiusura EE. La funzione Fotocellula Chiusura è associata ad un contatto normalmente chiuso. Durante la fase di installazione può essere utile disabilitare l'ingresso 3. Quando le fotocellule sono collegate all'ingresso 3 la centrale lo rileva e imposta E3 = EE(Fotocellula Chiusura). Se l'ingresso 3 è abilitato e attivo sui display appare: EE.</p>
<p>Ingresso 4 Fotocellula Apertura</p> <p>E4</p>	<p>E4 = n0 → DISABILITATO E4 = ER → ABILITATO</p> <p>L'ingresso 4 è configurabile con queste funzioni: Disabilitato n0 o Fotocellula Apertura ER. La funzione Fotocellula Apertura è associata ad un contatto normalmente chiuso. Durante la fase di installazione può essere utile disabilitare l'ingresso 4. Quando le fotocellule sono collegate all'ingresso 4 la centrale lo rileva e imposta E4 = ER(Fotocellula Apertura). Se l'ingresso 4 è abilitato e attivo sui display appare: ER.</p>
<p>Ingresso 5 Finecorsa Chiusura N.C. - Finecorsa Chiusura N.A.</p> <p>E5</p>	<p>E5 = n0 → DISABILITATO E5 = FL or LL → ABILITATO</p> <p>L'ingresso 5 è configurabile con queste funzioni: Disabilitato n0, Finecorsa Chiusura N.C. FL, Finecorsa Chiusura N.A. LL. La funzione Finecorsa Chiusura N.C. è associata ad un contatto normalmente chiuso. La funzione Finecorsa Chiusura N.A. è associata ad un contatto normalmente aperto. Se l'ingresso 5 è abilitato e attivo sui display appare: FL o LL.</p>
<p>Ingresso 6 Finecorsa Apertura N.C. - Finecorsa Apertura N.A.</p> <p>E6</p>	<p>E6 = n0 → DISABILITATO E6 = FR or LR → ABILITATO</p> <p>L'ingresso 6 è configurabile con queste funzioni: Disabilitato n0, Finecorsa Apertura N.C. FR, Finecorsa Apertura N.A. LR. La funzione Finecorsa Apertura N.C. è associata ad un contatto normalmente chiuso. La funzione Finecorsa Apertura N.A. è associata ad un contatto normalmente aperto. Se l'ingresso 6 è abilitato e attivo sui display appare: FR o LR.</p>
<p>Ingresso 7 Start Pedonale – Solo Apri – Solo Chiudi</p> <p>E7</p>	<p>E7 = n0 → DISABILITATO E7 = PE or 0P or CL → ABILITATO</p> <p>L'ingresso 7 è configurabile con queste funzioni: Disabilitato n0, Start Pedonale PE, Solo Apri 0P o Solo Chiudi CL. Le funzioni Start Pedonale, Solo Apri e Solo Chiudi sono associate a contatti normalmente aperti. Se questo ingresso non viene usato è consigliabile impostare E7 = n0. Se l'ingresso 7 è abilitato e attivo sui display appare: PE, 0P o CL.</p>

Default 	<p>Per ripristinare il default di fabbrica: mantenere premuto o premere ripetutamente il tasto A o B finché il display non visualizza . Dopo qualche secondo la centrale mostra .</p> <p>Per impostare il default premere il tasto C finché il display non mostra . Il default di fabbrica non ha nessun effetto sulla programmazione della radio.</p>								
Acquisizione sequenziale 	<p> è una procedura semiautomatica che permette l'acquisizione dei tempi di lavoro del cancello. I parametri interessati sono: ,  e . Prima di iniziare questa procedura assicurarsi che: tutti i dispositivi di sicurezza sono connessi, la centrale di controllo è in stand by e il senso di marcia del motore è corretto. Per iniziare questa procedura mantenere premuto il tasto A o B finché la centrale non mostra . Dopo qualche secondo sul display appare . Premendo un ingresso di start la procedura sarà avviata. La procedura è divisa in 3 passi: ,  e . Durante ogni passo il parametro associato viene programmato. Il sensore ostacoli è disabilitato per tutta la durata della procedura.</p> <table border="1" style="width: 100%; border-collapse: collapse;"> <tr> <td style="width: 15%; text-align: center; vertical-align: middle;">  → </td> <td> <p>La centrale di controllo è pronta per avviare la procedura di acquisizione sequenziale.</p> <p>Per passare al passo  premere un ingresso di start.</p> </td> </tr> <tr> <td style="text-align: center; vertical-align: middle;"></td> <td> <p>Si sta acquisendo il Tempo Normale del motore ().</p> <p>Il cancello si apre. Per passare al passo di programmazione successivo:</p> <p>Se il fine corsa d'apertura non è installato ( = ):</p> <ul style="list-style-type: none"> • Per passare al passo  premere un ingresso di start. <p>Se il fine corsa d'apertura è installato ( = ):</p> <ul style="list-style-type: none"> • Per passare al passo  premere un ingresso di start. • Per passare al passo  aspettare finché il cancello non raggiunge il fine corsa d'apertura. Un tempo extra di 10 secondi verrà aggiunto ad . </td> </tr> <tr> <td style="text-align: center; vertical-align: middle;"></td> <td> <p>Si sta acquisendo il Tempo Rallentamento del motore ().</p> <p>Il cancello rallenta. Per passare al passo di programmazione successivo:</p> <p>Se il fine corsa d'apertura non è installato ( = ):</p> <ul style="list-style-type: none"> • Per passare al passo  premere un ingresso di start. <p>Se il fine corsa d'apertura è installato ( = ):</p> <ul style="list-style-type: none"> • Per passare al passo  premere un ingresso di start. • Per passare al passo  aspettare finché il cancello non raggiunge il fine corsa d'apertura. Un tempo extra di 30 secondi verrà aggiunto ad . </td> </tr> <tr> <td style="text-align: center; vertical-align: middle;"></td> <td> <p>Si sta acquisendo il Tempo Di Pausa (). Il motore è fermo.</p> <p>Il lampeggiatore è acceso fisso. Dopo 1.5 secondi il display mostra il tempo di conteggio. Per completare la procedura premere un ingresso di start e attendere la chiusura completa del cancello.</p> </td> </tr> </table>	  → 	<p>La centrale di controllo è pronta per avviare la procedura di acquisizione sequenziale.</p> <p>Per passare al passo  premere un ingresso di start.</p>		<p>Si sta acquisendo il Tempo Normale del motore ().</p> <p>Il cancello si apre. Per passare al passo di programmazione successivo:</p> <p>Se il fine corsa d'apertura non è installato ( = ):</p> <ul style="list-style-type: none"> • Per passare al passo  premere un ingresso di start. <p>Se il fine corsa d'apertura è installato ( = ):</p> <ul style="list-style-type: none"> • Per passare al passo  premere un ingresso di start. • Per passare al passo  aspettare finché il cancello non raggiunge il fine corsa d'apertura. Un tempo extra di 10 secondi verrà aggiunto ad . 		<p>Si sta acquisendo il Tempo Rallentamento del motore ().</p> <p>Il cancello rallenta. Per passare al passo di programmazione successivo:</p> <p>Se il fine corsa d'apertura non è installato ( = ):</p> <ul style="list-style-type: none"> • Per passare al passo  premere un ingresso di start. <p>Se il fine corsa d'apertura è installato ( = ):</p> <ul style="list-style-type: none"> • Per passare al passo  premere un ingresso di start. • Per passare al passo  aspettare finché il cancello non raggiunge il fine corsa d'apertura. Un tempo extra di 30 secondi verrà aggiunto ad . 		<p>Si sta acquisendo il Tempo Di Pausa (). Il motore è fermo.</p> <p>Il lampeggiatore è acceso fisso. Dopo 1.5 secondi il display mostra il tempo di conteggio. Per completare la procedura premere un ingresso di start e attendere la chiusura completa del cancello.</p>
  → 	<p>La centrale di controllo è pronta per avviare la procedura di acquisizione sequenziale.</p> <p>Per passare al passo  premere un ingresso di start.</p>								
	<p>Si sta acquisendo il Tempo Normale del motore ().</p> <p>Il cancello si apre. Per passare al passo di programmazione successivo:</p> <p>Se il fine corsa d'apertura non è installato ( = ):</p> <ul style="list-style-type: none"> • Per passare al passo  premere un ingresso di start. <p>Se il fine corsa d'apertura è installato ( = ):</p> <ul style="list-style-type: none"> • Per passare al passo  premere un ingresso di start. • Per passare al passo  aspettare finché il cancello non raggiunge il fine corsa d'apertura. Un tempo extra di 10 secondi verrà aggiunto ad . 								
	<p>Si sta acquisendo il Tempo Rallentamento del motore ().</p> <p>Il cancello rallenta. Per passare al passo di programmazione successivo:</p> <p>Se il fine corsa d'apertura non è installato ( = ):</p> <ul style="list-style-type: none"> • Per passare al passo  premere un ingresso di start. <p>Se il fine corsa d'apertura è installato ( = ):</p> <ul style="list-style-type: none"> • Per passare al passo  premere un ingresso di start. • Per passare al passo  aspettare finché il cancello non raggiunge il fine corsa d'apertura. Un tempo extra di 30 secondi verrà aggiunto ad . 								
	<p>Si sta acquisendo il Tempo Di Pausa (). Il motore è fermo.</p> <p>Il lampeggiatore è acceso fisso. Dopo 1.5 secondi il display mostra il tempo di conteggio. Per completare la procedura premere un ingresso di start e attendere la chiusura completa del cancello.</p>								

DICHIARAZIONE DI CONFORMITA'

Fabbricante: **Quiko Italy Sas**
Via Seccalegno, 19
36040 Sossano (VI)
Italia

dichiara sotto la propria responsabilità che il prodotto:
Quadro di comando **QK-CE220RL4**

è conforme ai requisiti essenziali di sicurezza delle direttive:

- ✓ Apparecchiature Radio - **1999/5/CE**;
- ✓ Bassa Tensione - **2006/95/CE**;
- ✓ Compatibilità Elettromagnetica - **2004/108/CE**;

nonché alle loro modificazioni e aggiornamenti, e alle disposizioni che ne attuano il recepimento all'interno dell'Ordinamento Legislativo Nazionale del paese di destinazione e utilizzo della macchina.

Sossano, 10/11/2012

Il Legale Rappresentante
Luca Borinato





Quiko Italy

Via Seccalegno, 19
36040 Sossano (VI) - Italy
Tel. +39 0444 785513
Fax +39 0444 782371
info@quiko.biz
www.quikoitaly.com



*The Manufacturer can technically improve
the quality of its products without
any prior notice.*

www.quikoitaly.com

