

# INSTRUCTION MANUAL

## V01/2019

Control Board with Inverter

# QK-CE220RLINV



**For Industrial automation**  
**230Vac single phase power supply**  
**230Vac three-phase motor output**



**WARNING!!** Before installing, thoroughly read this manual that is an integral part of this Kit. QUIKO declines any responsibility in the event current standards in the country of installation are not complied with.

**qui** > **lö**®  
opening solutions

## Main features:

- Open and close Frequency of work separately adjustable
- Acceleration Ramp / adjustable deceleration and slowdown speed
- Amperometric with obstacle sensitivity adjustable in opening and in closing
- Logic obstacle inversion adjustable in opening and in closing.
- Input for safety edge NC / 8.2 kohm
- Inputs for photocell-safeties in opening and closing
- Inputs Open / Close / Partial and Step-by-Step
- Programs modes : automatic, semi-automatic or deadman selectable
- Inputs status and functions viewable on display
- Optional plug-in receiver plug-in for the management of fixed code transmitters or Rolling-code

## Layout description

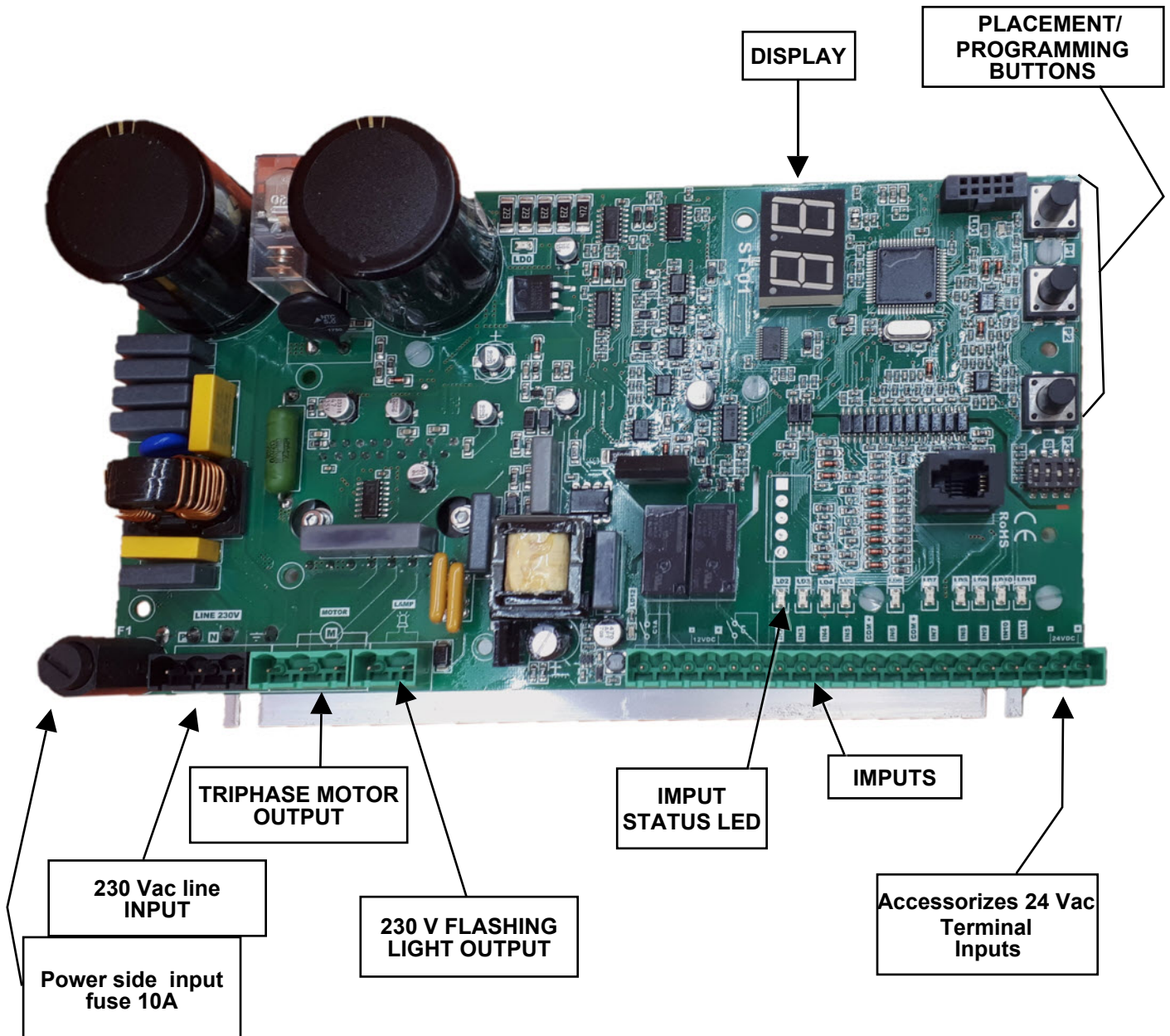

## General Characteristics :

- Programming and self-learning via keys (increase, decrease, validation) and a figures display
  - Management of three safety devices as photocell, a safety device inclosing and in opening.
  - Contact for signaling automation / alarm state
  - 12Vac Contact for control safety / auxiliary functions power
- 
- Extractable power and signal Terminals
  - Predisposed for coupling with filter
  - Complies with European Directives Reference:  
Low Voltage 73/23 / EEC  
Electromagnetic Compatibility (EMC) Directive 89/336 / EEC  
**(NB: only if installed mains filter or equivalent)**



**FILTER**

## Specifications:

<b>Power supply</b>	230Vac
<b>Output Motor</b>	Three phase 230 VAC – Single phase 230 Vac
<b>Three phase motor connection</b>	Triangle
<b>Single phase motor connection</b>	No capacitor
<b>Motor power</b>	2HP
<b>Environmental conditions</b>	-20°C / + 55 °C
<b>Accessories power supply</b>	12-24 VDC/AC – 4 Watt For higher powers, install an external transformer

## Protections:

- Motor protected by a fuse and electronic control
- Power circuits electronically protected by varistors.
- Secondary transformer, protected by self-resetting fuse and transil.
- Filter capacitors on the input network



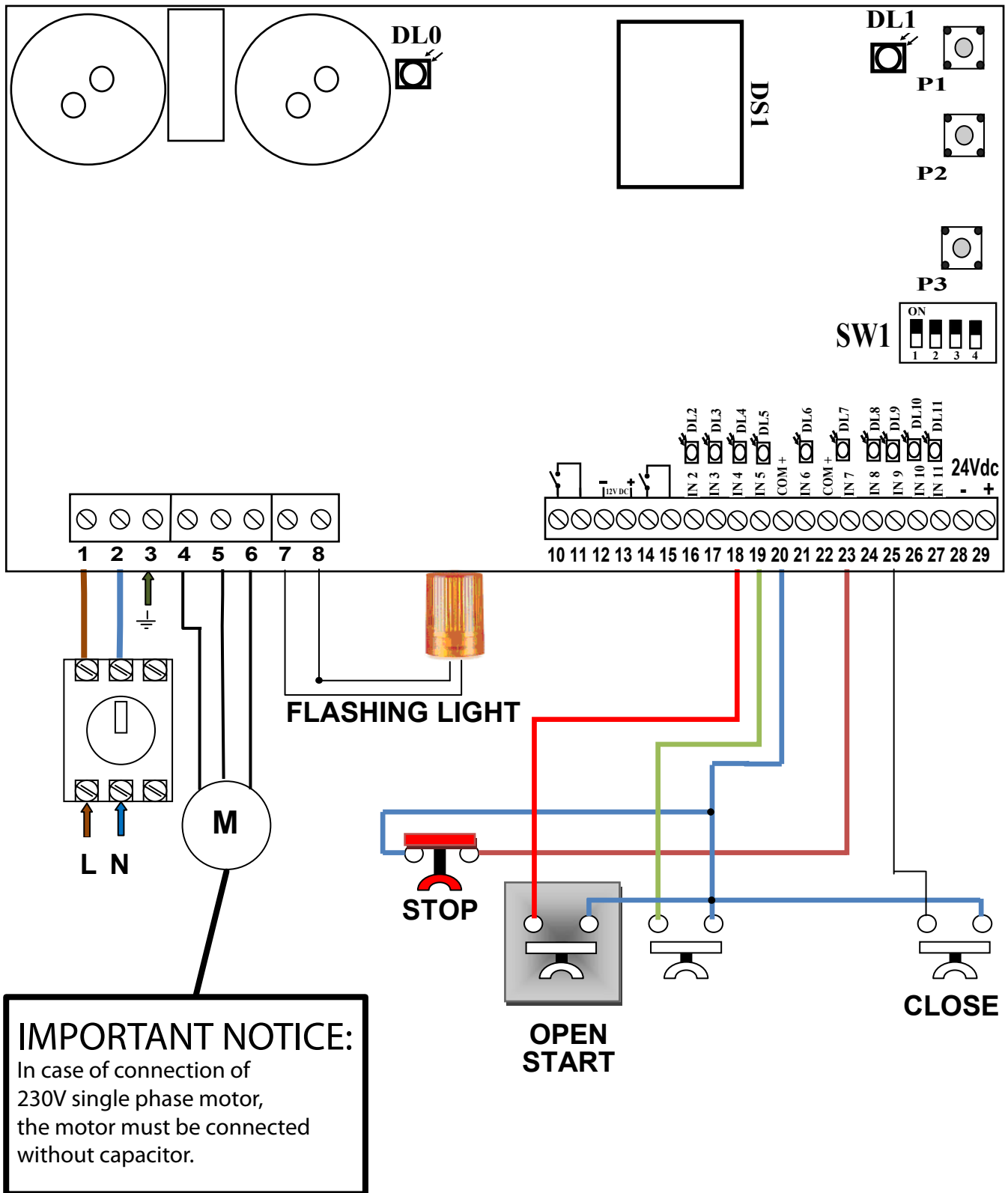



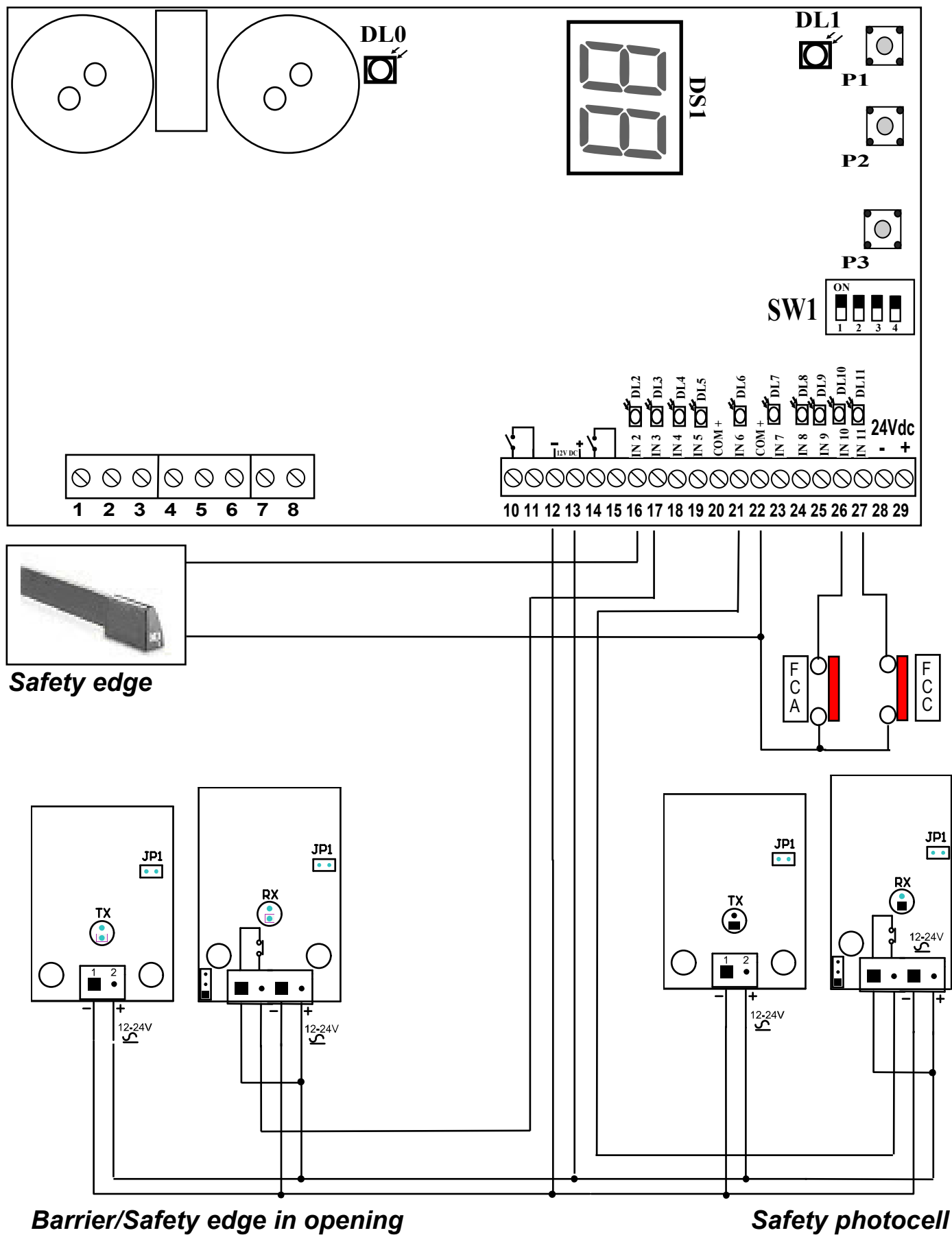

# Wiring MOTOR / FLASHING LIGHT/ COMMANDS / SAFETY DEVICES























# SAFETY DEVICES WIRINGS



# Terminal numbering / LEDs meaning

	<b>1</b>	Input Phase Power Supply 230Vac
	<b>2</b>	Input Neutral Power Supply 230Vac
	<b>3</b>	Input Ground Power Supply 230Vac
	<b>4</b>	Output Phase 1 motor
	<b>5</b>	Output Phase 2 motore
	<b>6</b>	Output Phase 3 motor
	<b>7</b>	Output flashing light 230V
	<b>8</b>	Common flashing light

	<b>10</b>	Output voltage con tact NO
	<b>11</b>	
	<b>12</b>	OUTPUT-12Vdc accessoires
	<b>13</b>	OUTPUT +12Vdc accessoires (common)
	<b>14</b>	Output voltage con tact NO
	<b>15</b>	
	<b>16</b>	INPUT safety edge
	<b>17</b>	INPUT barrier/safety edge in opening
	<b>18</b>	INPUT START
	<b>19</b>	INPUT PEDESTRIAN
	<b>20</b>	Common inputs 12Vdc
	<b>21</b>	INPUT safety photocell
	<b>22</b>	COMMON inputs 12Vdc
	<b>23</b>	INPUT STOP
	<b>24</b>	INPUT OPEN
	<b>25</b>	INPUT CLOSE
	<b>26</b>	INPUT OPEN LIMIT SWITCH
	<b>27</b>	INPUT CLOSE LIMIT SWITCH
	<b>28</b>	Output - 24Vdc
	<b>29</b>	Output +24Vdc

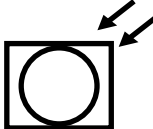
**LD 0** 

**Led indication discharge of capacitors.**  
After disconnecting the power supply, wait LD0 turns off before working on the controller.

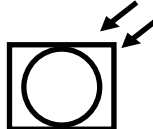
**LD 1** 

**LED ACTIVITY MICROCONTROLLER**

	LD2
	LD3
	LD4
	LD5
	LD6
	LD7
	LD8
	LD9
	LD10
	LD11

## SETTINGS and PROGRAMMING

- **Verify the direction of rotation of motor**

After connecting, unlock the motor , place the door outside the closing limit switch,

re-lock the engine and give power to the electrical panel.

Use buttons on board having the following features:

**P1 key CLOSE**

**P2 key OPEN**

**P3 key CONFIRM / SELECT PROGRAMMING PHASE**

- Check that pressing the P1 the door closes and bring it up to the closed position, verify that LD11 goes off.
- Otherwise reverse ONLY 2 of the 3 motor phases.

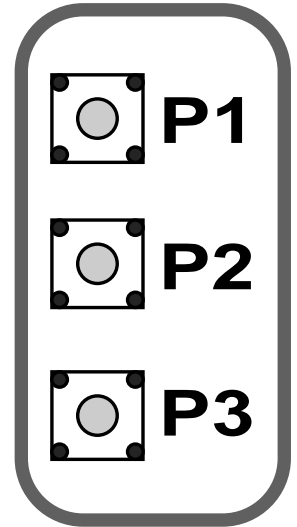

- Check that on the display DS1 appears the message  $[H = \text{DOOR CLOSED}$

- Check that the LED LD11 related to FCC is off

- **Function 01 - Select type of automation motor three-phase 230Vac**

**01** = PS (Sliding Door / Sectional / Gate).

**02** = PF (Fridge Door).

**03** = PL (Folding Door).

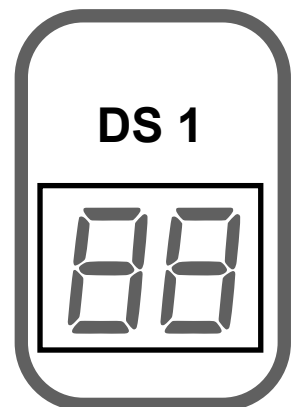

### PROCEDURE:

Press P3 until the display shows **01** and release.

Press again P3 and release.

The display shows **01** = sliding gate.

**(NOTE: The sub-menu selection is distinguished from the point after the digit).**

If you need to select another type of automation, act on the P2 button to display the number corresponding to the type of automation desired.

Confirm pressing P3 (at this point will disappear the dots to the left of the digits).

**After programming follow the procedure for ESC:**

Press **P2** (Forward) or **P1** (Backward) | you see **E5**

Confirm pressing **P3**.

Note:

FACTORY SETTING	Min/Max	Pre-set		
		PS	PF	PL
Opening speed frequency in Hz	01 ÷ 99	50Hz	25Hz	50Hz
Closing speed frequency in Hz	01 ÷ 99	50Hz	25Hz	50Hz
Opening in slow speed frequency in Hz	01 ÷ 99	25Hz	15Hz	30Hz
Closing in slow speed frequency in Hz	01 ÷ 99	25Hz	15Hz	30Hz

## Function 02 - Select type of automation motor single-phase 230Vac

0.1 = PS (Sliding Door / Sectional / Gate).

0.2 = PF (Fridge door).

0.3 = PL (Folding door).

### PROCEDURE:

Press P3 until 0.1 appears on the display, then release.

Press P2 (Forward) 0.2 appears

Press again P3 and release.

On Display appears 0.1 = Sliding door.

**(NOTE: The sub-menu selection is distinguished from the point after the digit).**

If you need to select another type of automation press the P2 button to display the number corresponding to the type of automation desired.

Confirm with P3.

**After programming follow the procedure for ESC:**

Press P2 (Forward) or P1 (Backward) until you see E5

Confirm pressing P3.

### • Learning of opening and closing work times

**⚠ Automation in the closed position and check the position of the DIP 4**

### PROCEDURE:

- Hold the P3 until the display shows E
- Press **start**: automation will start in opening
- Press start when you want to begin slowing down.
- Arrived on the opening limit switch, automation will stop.
- Wait until the desired wait time and press start.
- The automation starts closing.
- Press start when you want to begin slowing down.
- Arrived on the opening limit switch, automation will stop.

**NOTE: During this phase, the board detects the the current absorption curve, for the obstacle detection.**



## • Select type of logic for START input with DIP 4

**⚠ This type of logic is to be selected after the Learning-Phase**

- **DIP4 in OFF** : The input-**Start Open**, assumes the function of the Start. So button connected to this input will function either by command that opens and closes.
- **DIP4 in ON** : The entrance Start-Open, assumes the function of command opens both impulsive or dead man. So, the button connected to this input, it will work just as command opens. In this case, will have to be used the Command Closes, (Close) for the reclosing.

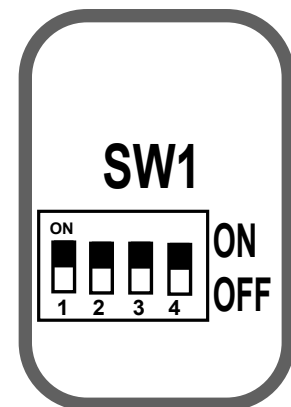

## • Learning partial working time (Pedestrian)

- Place the automation in closed position
- Hold the P3 until the display shows **E**
- Press pedestrian **start**: automation will start in opening
- Press pedestrian start when you want the automation to stop.
- Wait until the desired wait time and press pedestrian start.
- The automation starts closing.
- Arrived on the opening limit switch, automation will stop.

## Function 03 - Changing pause time

- Hold the P3 until the display shows **0** | e release P3
- Press repeatedly P2 until **03** appears on the display.
- Press P3 and on the display **0.4** appears = 4 seconds of pause or the one set in learning.
- Press the button P1 to increase and P2 to decrease the time in seconds
- Press P3 for confirmation

**If you want to quit the programming mode follow the procedure for ESC:**

Press **P2** (Forward) or **P1** (Backward) until you see **E5**

Confirm pressing **P3**.

## Function 04 – Max torque adjustment.

- Hold the P3 until the display shows **0** | e release P3
- Press repeatedly P2 until **04** appears on the display.
- Press P3, the display show **9.9** = the percentage of the maximum torque set.
- Press the button P1 to increase and P2 to decrease the value.
- Press P3 for confirmation

**If you want to quit the programming mode follow the procedure for ESC:**

Press **P2** (Forward) or **P1** (Backward) until you see **E5**

Confirm pressing **P3**.

## Function 05 – Opening frequency setting in Hz

- Hold the P3 until the display shows **01** e release P3
- Press repeatedly P2 until **05** appears on the display
- Press P3 the display shows **5.0** equal to the frequency set.
- Press the button P1 to increase and P2 to decrease the value
- Press P3 for confirmation.

**If you want to quit the programming mode follow the procedure for ESC:**

Press **P2** (Forward) or **P1** (Backward) until you see **E5**

Confirm pressing **P3**.

## Function 06 – Closing frequency setting in Hz

- Hold the P3 until the display shows **01** e release P3
- Press repeatedly P2 until **06** appears on the display
- Press P3 the display shows **5.0** equal to the frequency set.
- Press the button P1 to increase and P2 to decrease the value
- Press P3 for confirmation.

**If you want to quit the programming mode follow the procedure for ESC:**

Press **P2** (Forward) or **P1** (Backward) until you see **E5**

Confirm pressing **P3**.

Note:

FACTORY SETTINGS	Min/Max	Pre-Set		
		PS	PF	PL
Opening speed frequency in Hz	01 ÷ 99	50Hz	25Hz	50Hz
Closing speed frequency in Hz	01 ÷ 99	50Hz	25Hz	50Hz
Opening in slow speed frequency in Hz	01 ÷ 99	25Hz	15Hz	30Hz
Closing in slow speed frequency in Hz	01 ÷ 99	25Hz	15Hz	30Hz

## Function 07 – Opening slowing down frequency setting in Hz.

- Hold the P3 until the display shows **01** e release P3
- Press repeatedly P2 until **07** appears on the display
- Press P3 the display shows **3.0** equal to the frequency set.
- Press the button P1 to increase and P2 to decrease the value
- Press P3 for confirmation.

**If you want to quit the programming mode follow the procedure for ESC:**

Press **P2** (Forward) or **P1** (Backward) until you see **E5**

Confirm pressing **P3**.

## Function 08 – Closing slowing down frequency setting in Hz

- Hold the P3 until the display shows **01** e release P3
- Press repeatedly P2 until **08** appears on the display
- Press P3 the display shows **3.0** equal to the frequency set.
- Press the button P1 to increase and P2 to decrease the value
- Press P3 for confirmation.

**If you want to quit the programming mode follow the procedure for ESC:**

Press **P2** (Forward) or **P1** (Backward) until you see **E5**

Confirm pressing **P3**.

## Function 09 – Amperometric sensitivity in Open from 01 to 99

- Hold the P3 until the display shows **01** e release P3
- Press repeatedly P2 until **09** appears on the display
- Press P3 the display shows **5.0** equal to the sensitivity set.
- Press the button P1 to increase and P2 to decrease the value

 To disable the control, set **0.0**

- **Note: id. 01= very sensitive – 99= less sensitive.**

**If you want to quit the programming mode follow the procedure for ESC:**

Press **P2** (Forward) or **P1** (Backward) until you see **E5**

Confirm pressing **P3**.

## Function 10 – Amperometric sensitivity in Close from 01 to 99

- Hold the P3 until the display shows **01** e release P3
- Press repeatedly P2 until **10** appears on the display
- Press P3, the display shows **5.0** equal to the sensitivity set.
- Press the button P1 to increase and P2 to decrease the value

 To disable the control, set **0.0**

- **Note: id. 01= very sensitive – 99= less sensitive.**

**If you want to quit the programming mode follow the procedure for ESC:**

Press **P2** (Forward) or **P1** (Backward) until you see **E5**

Confirm pressing **P3**.

## Function 11 – Amperometric sensitivity in slow Open from 01 to 99

- Hold the P3 until the display shows **01** e release P3
- Press repeatedly P2 until **11** appears on the display
- Press P3, the display shows **5.0** equal to the sensitivity set.
- Press the button P1 to increase and P2 to decrease the value

**⚠** To disable the control, set **0.0**

- **Note: id. 01= very sensitive – 99= less sensitive.**

**If you want to quit the programming mode follow the procedure for ESC:**

Press **P2** (Forward) or **P1** (Backward) until you see **E5**

Confirm pressing **P3**.

## Function 12 – Amperometric sensitivity in slow Close from 01 to 99

- Hold the P3 until the display shows **01** e release P3
- Press repeatedly P2 until **12** appears on the display
- Press P3, the display shows **5.0** equal to the sensitivity set.
- Press the button P1 to increase and P2 to decrease the value

**⚠** To disable the control, set **5.0**

- **Note: id. 01= very sensitive – 99= less sensitive.**

**If you want to quit the programming mode follow the procedure for ESC:**

Press **P2** (Forward) or **P1** (Backward) until you see **E5** Confirm pressing **P3**.

## Function 13 – Starting blow from 1 to 20 (tenths of a second)

- Hold the P3 until the display shows **01** e release P3
- Press repeatedly P2 until **13** appears on the display
- Press P3, the display shows **0.0** = Disabled.
- Set the time in tenths of a second
- Press the button P1 to increase and P2 to decrease the value. Ex. ( **1.0** )
- Press P3 for confirmation

**If you want to quit the programming mode follow the procedure for ESC:**

Press **P2** (Forward) or **P1** (Backward) until you see **E5**

Confirm pressing **P3**.

## **Funzione 14 –Final blow after limit switch 1 to 20 (tenths of a second)**

- Hold the P3 until the display shows **0 1** e release P3
- Press repeatedly P2 until **14** appears on the display
- Press P3, the display shows **0.0** = Disabled.
- Set the time in tenths of a second
- Press the button P1 to increase and P2 to decrease the value. Ex. (**1.0**)
- Press P3 for confirmation

**If you want to quit the programming mode follow the procedure for ESC:**

Press **P2** (Forward) or **P1** (Backward) until you see **E5**

Confirm pressing **P3**.

## **Funcion 15 – Function test enabling**

- Hold the P3 until the display shows **0 1** e release P3
- Press repeatedly P2 until **15** appears on the display
- Press P3, the display shows **0.0** = Disabled.
- Set the time of start delay in second
- Press the button P1 to increase and P2 to decrease the value of the start. Ex. (**3.0**)
- Press P3 for confirmation.

**If you want to quit the programming mode follow the procedure for ESC:**

Press **P2** (Forward) or **P1** (Backward) until you see **ES**

Confirm pressing **P3**.

## **Function 16 – Count Maneuvers.**

- Hold the P3 until the display shows **0 1** e release P3.
- Press repeatedly P2 until **16** appears on the display
- Press P3 to view tens / units
- Press P2 for thousands / hundreds
- Press P2 for hundreds-thousands / tens-thousands
- Press P3 for confirmation.

**If you want to quit the programming mode follow the procedure for ESC:**

Press **P2** (Forward) or **P1** (Backward) until you see **E5**

Confirm pressing **P3**.

## Dead man function setting **UP**



- Hold the P3 until the display shows **01** e release P3.
- Press repeatedly P2 until **UP** appears on the display
- Press P3 to confirm and select with P2 **SI** yes or **NO**
- Press P3 to confirm the selection

## Dip Switch meaning

**Dip 1 ON** : automatic reclosure enabled  
**Dip 1 OFF** : automatic reclosure disabled

**Dip 2 ON** : inversion on start during closing enabled  
**Dip 2 OFF** : inversion on start during closing disabled

**Dip 3 ON** : does not accept start when opening and opened  
**Dip 3 OFF** : accept start when opening and opened

**Dip 4 ON** :  Button works like open command  
**Dip 4 OFF** :  Button works like start command

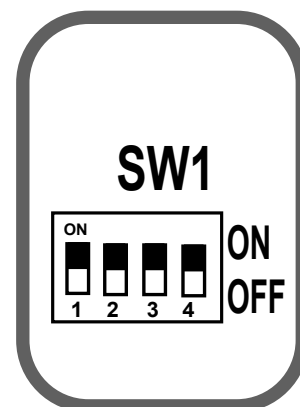

## Possible Errors reported on LED DS1

- E1** Error 1.
- E2** Short circuit.
- E3** Setup FF failure.
- E4** Capacitors charge failure.
- E5** High Temperature.
- E6** Instantaneous overcurrent.
- E7** Delayed overcurrent..
- E8** Bus overvoltage.

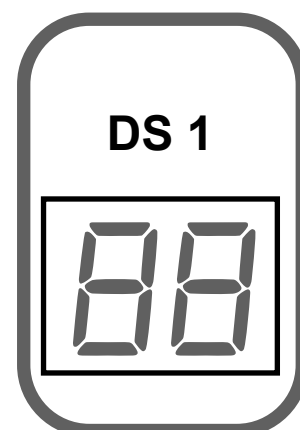

## INDICATIONS ON DISPLAY DS1

- CH** Door closed.
- CL** Door closing.
- OP** Door opening.
- AP** Door opened.
- EE** Self-learning.
- St** Stop pressed.
- 01** Three-phase motor 230Vac
- 02** Single-phase motor 230Vac
- 0.1.** Sliding gate **0.2.** Fridge door **0.3.** Sectional door;  
confirm with P3.
- 03** Regulation pause time:  
P2 1 second increment,  
P1 1 second decrement,  
Confirm with P3.
- 04** Max torque Display number of operation.
- 05** Frequency regulation OPEN
- 06** Frequency regulation CLOSE
- 07** Frequency slowing down regulation OPEN
- 08** Frequency slowing down regulation CLOSE
- 09** Amperometric sensitivity Open
- 10** Amperometric sensitivity Close
- 11** Amperometric sensitivity slow Open
- 12** Amperometric sensitivity slow Close
- 13** Starting blow.
- 14** Closing blow.
- 15** Test.
- 16** Count Maneuvers.
- UP** Deadman only operation. If activated display **UP**.
- ES** Press P3 to exit.

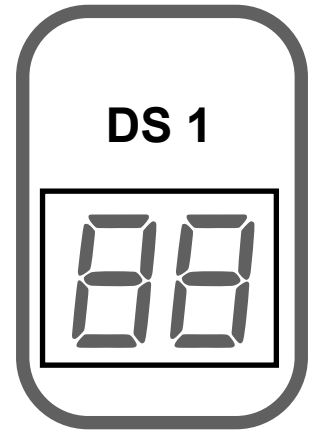



**QUIKO ITALY**

Via Seccalegno, 19  
36040 Sossano (VI) - Italy  
Tel. +39 0444 785513  
Fax +39 0444 782371  
**info@quiko.biz**  
**www.quikoitaly.com**

**DECLARATION OF CONFORMITY**

The manufacturer claims that the device complies with the essential safety requirements of the directives:

- Radio equipment - **1999/5 / EC**;
- Low Voltage - **73/23 / EEC, 93/68 / EEC** (EN 60335-1 (1998));
- Electromagnetic Compatibility - **89/336 / EEC, 93/68 / EEC, 98/37 / EC** (EN 50081-1, EN 50081-2, EN 61000-3-2, EN 61000-3-2 / A1, EN 61000-3-2 / A2, EN 61000-3-2 / A14, EN61000-3-3, EN 61000-6-2, ETSI EN 300220-3, ETSI EN 301489-3, ETSI EN 301489-1)

As well as their changes and updates, and the provisions that implement their assimilation within the National Legal System of the country of destination and use of the car.

The data and images are purely indicative reserves the right to modify at any time characteristics of the products described in its sole discretion, without notice.





# ISTRUCCIONES DE USO

## V01/2019

Control automatizaciones  
a INVERTER

# QK-CE220RLINV

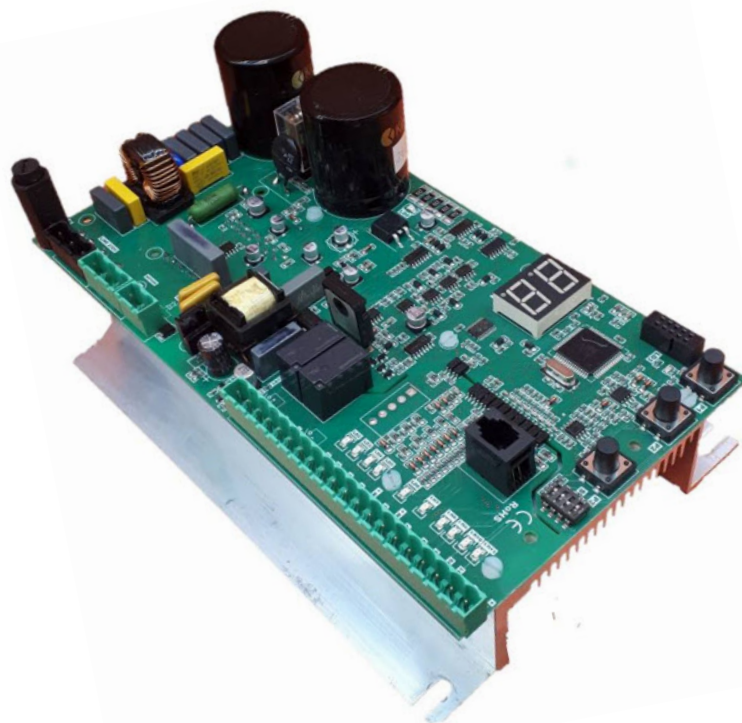

para automatizaciones Industriales  
alimentación monofásica 230Vac  
salida motor trifásica 230Vac



¡ATENCIÓN!! Antes de efectuar la instalación, lea atentamente el presente manual.  
La Empresa QUIKO no asumirá responsabilidad alguna en caso de inobservancia de las normas vigentes en el país donde se lleva a cabo la instalación

**quikö**<sup>®</sup>  
opening solutions

## Características principales:

- Frecuencia de trabajo en apertura y en cierre ajustable separado
- Rampa de aceleración / deceleración y velocidad del paro suave ajustable
- Amperométrica con sensibilidad ajustable tanto en apertura y cierre
- Inversión regulable en apertura y cierre.
- Entrada para banda de seguridad NC / 8,2 kohm
- Entrada para fotocélula-seguridad en apertura y cierre
- Entradas Abrir / Cerrar / Parcial y Paso a paso
- Programación de funcionamiento: automático, semiautomático o de hombre presente seleccionable
- Visualizaciones de estado, y la función de asignación a través del menú de la pantalla
- Receptor enchufe opcional para la gestión de los transmisores de código fijo o Rollin-code

## Descripción General

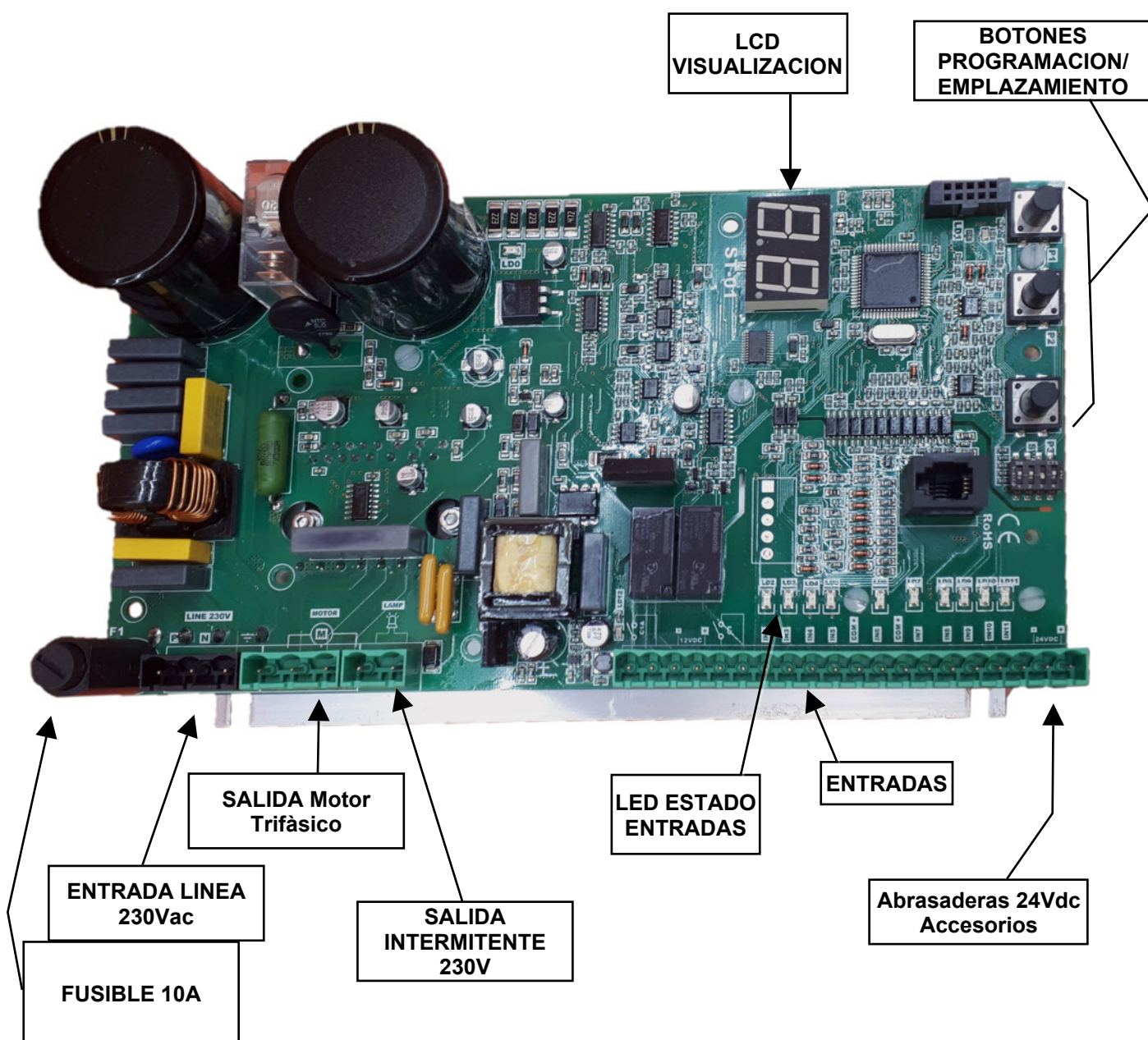

## Características generales

- Programación y auto aprendizaje con botones (aumento, disminución, convalidación) y un display a dos cifras
- Gestión de tres medidas de seguridad: una fotocélula, una seguridad en cierre y una en apertura.
- Contacto limpio para señalar estado automatización/alarme
- Contacto 12Vac para control alimentación seguridad/funciones auxiliares

Abrasaderas de potencia y de señal extraíbles

Predispuesta para acoplamiento con filtro de red

- Conforme a las Directivas Europeas de referencia: Baja Tensión 73/23/CEE
- Compatibilidad Electromagnética (EMC) 89/336/CEE
- (N.B. : solamente si instalado el filtro de red o equivalentes)



FILTRO

## Características Técnicas

Alimentación	230Vac
Salida motor	Trifásico 230 VAC – Monofásico 230 Vac
Conexión motor Trifásico	A Triángulo
Conexión motor Monofásico	No condensador
Potencia motor	2HP
Temp. funcionamiento	-20°C / + 55 °C
Alimentación accesorios	12-24 VDC/AC – 4 Watt Para potencias superiores instalar transformador externo

## Protecciones

- Motor protegido con fusible y de control electrónico
- Circuitos de potencia protegidos electrónicamente y a través de varistores.
- Secundario transformador, protegido con fusible auto ajustable y transil.
- Condensadores de filtro en el ingreso de la red.

# Conexiones MOTOR / INTERMITENTE/ COMANDOS

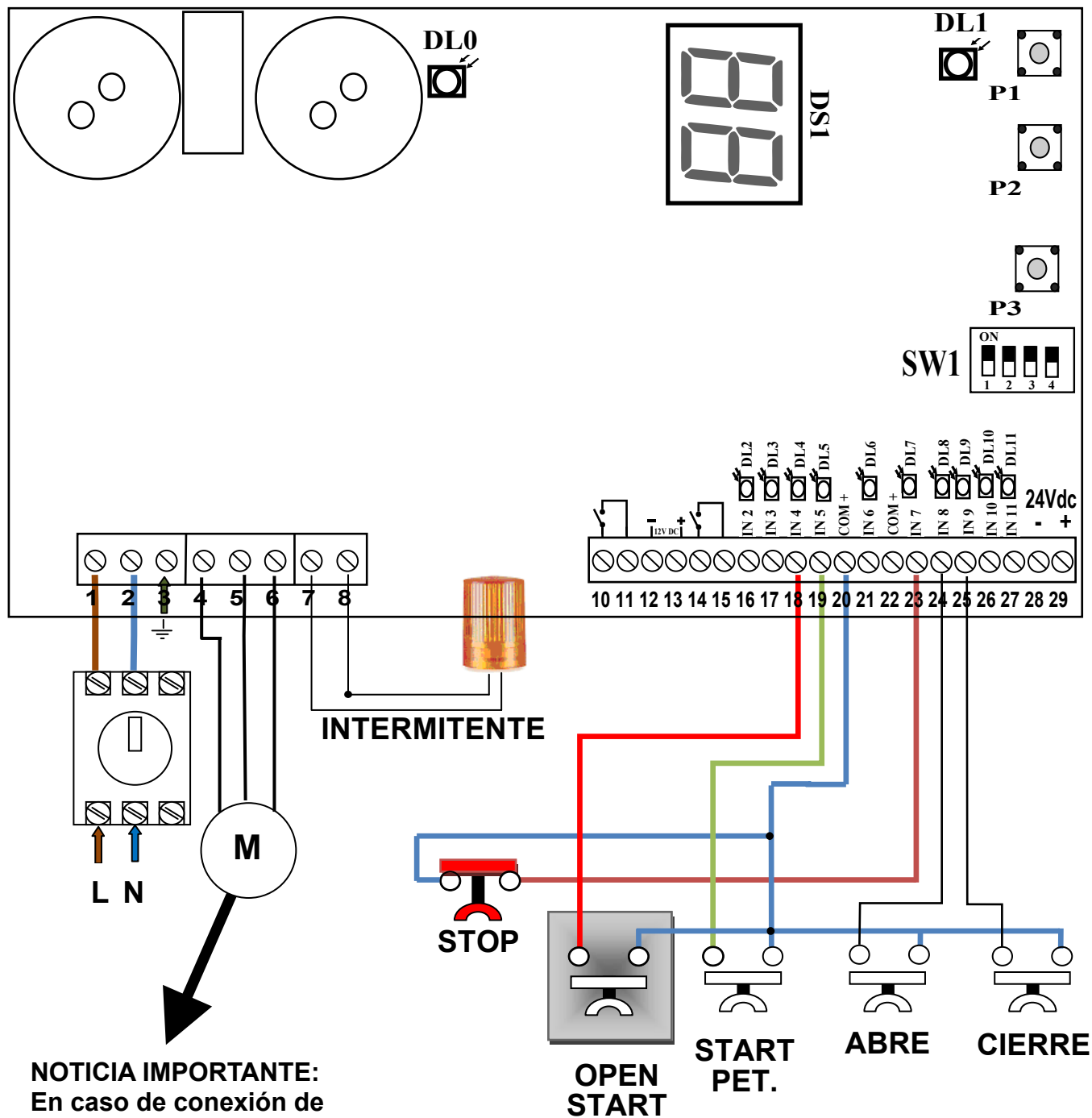

**NOTICIA IMPORTANTE:**  
 En caso de conexión de Motor monofásico de 230V, el motor debe estar conectado sin condensador

# Conexi3n DISPOSITIVOS DE SEGURIDAD

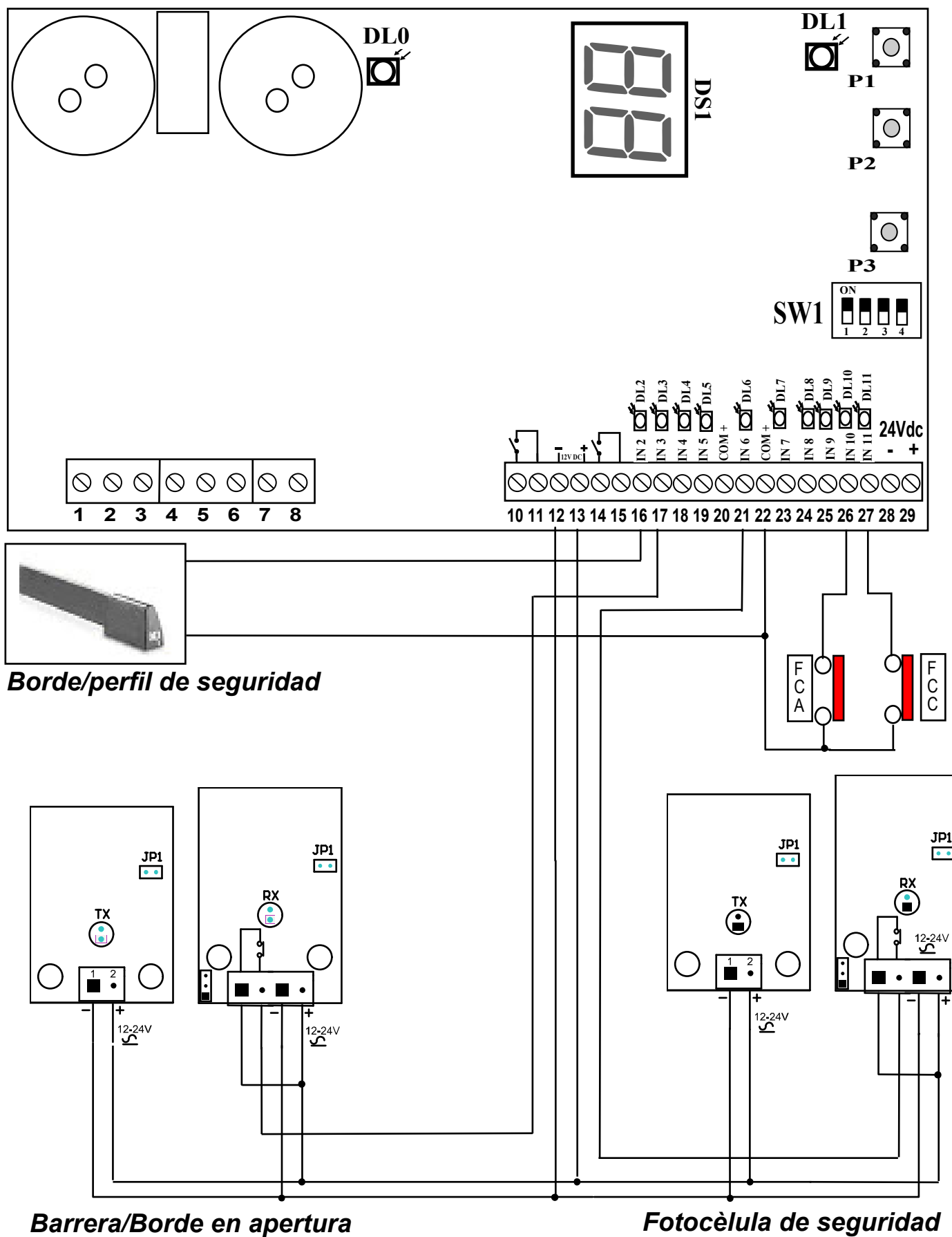

# Numeración ABRASADERA \ significado LED

	<b>1</b>	<b>ENTRADA FASE Alimentación 230Vac</b>
	<b>2</b>	<b>ENTRADA NEUTRAL Alimentación 230Vac</b>
	<b>3</b>	<b>ENTRADA TIERRA Alimentación 230Vac</b>
	<b>4</b>	<b>SALIDA FASE 1 motor</b>
	<b>5</b>	<b>SALIDA FASE 2 motor</b>
	<b>6</b>	<b>SALIDA FASE 3 motor</b>
	<b>7</b>	<b>SALIDA Intermitente 230V</b>
	<b>8</b>	<b>COMUN Intermitente</b>

**LD 0**

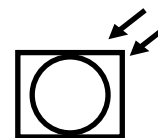







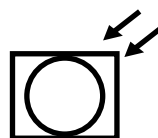

**LED indicación descarga condensadores.**











Después de eliminar la alimentación, esperar que LD0 si apage antes de intervenir en la central.

**LD 1**



**LED ACTIVIDAD MICROCONTROLOR**

	<b>10</b>	<b>SALIDA contacto limpio NA</b>
	<b>11</b>	
	<b>12</b>	<b>SALIDA - 12Vdc accesorios</b>
	<b>13</b>	<b>SALIDA + 12Vdc accesorios (COMUN)</b>
	<b>14</b>	<b>SALIDA contacto limpio NA</b>
	<b>15</b>	
	<b>16</b>	<b>ENTRADA borde de seguridad</b>
	<b>17</b>	<b>ENTRADA barrera / Bordo en apertura</b>
	<b>18</b>	<b>ENTRADA START</b>
	<b>19</b>	<b>ENTRADA START PEATONAL</b>
	<b>20</b>	<b>ENTRADAS COMUNES 12Vdc</b>
	<b>21</b>	<b>ENTRADA FOTOCELULA SEGURIDAD</b>
	<b>22</b>	<b>ENTRADAS COMUNES 12Vdc</b>
	<b>23</b>	<b>ENTRADA STOP</b>
	<b>24</b>	<b>ENTRADA ABRE</b>
	<b>25</b>	<b>ENTRADA CIERRE</b>
	<b>26</b>	<b>ENTRADA FIN-CARRERA ABRE</b>
	<b>27</b>	<b>ENTRADA FIN-CARRERA CIERRE</b>
	<b>28</b>	<b>SALIDA - 24Vdc</b>
	<b>29</b>	<b>SALIDA + 24Vdc</b>

	LD2
	LD3
	LD4
	LD5
	LD6
	LD7
	LD8
	LD9
	LD10
	LD11

# AJUSTES Y PROGRAMACION

## • Verificar sentido de rotación motor

Terminadas las conexiones, con el motor desbloqueado, poner la puerta fuera del fin-carrera de cierre, bloquear otra vez el motor y dar alimentación al cuadro eléctrico.

Usar los botones del tablero con las siguientes funciones:

**P1 botón CIERRA**

**P2 botón ABRE**

**P3 botón CONFIRMA/SELECCION FASE PROGRAMACION**

- Verificar que pulsando el botón P1 la puerta cierre y llevarla hasta la posición de cerrado, verificar que LD11 se apague.
- De lo contrario invertir SOLO 2 de las 3 fases motor.

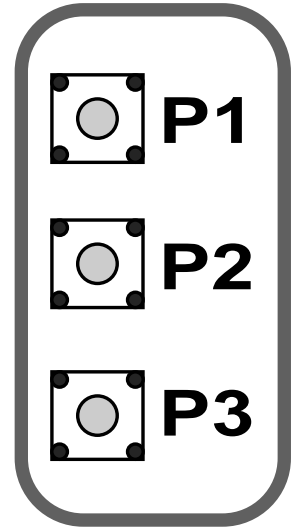

- Verificar que en el display DS1 aparezca escrito  $[H = \text{Portón cerrado}$

- Verificar que el led LD11 relativo a FCC este apagado

- **Función 01** - Seleccionar tipo de automatización con motor trifásico 230Vac

**0.1** = PS (Puerta Corrediza/Seccional/Cancela).

**0.2** = PF (Puerta Nevera).

**0.3** = PL (Puerta a Libro).

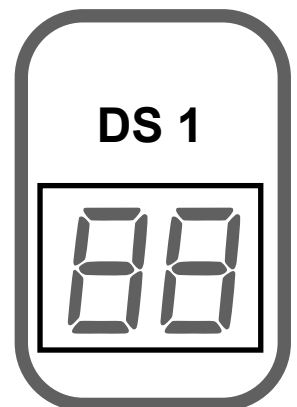

## PROCEDIMIENTO:

Pulsar P3 hasta que en el display aparezca **0.1** y liberar.

Pulsar otra vez P3 y liberar.

En el Display aparezca **0.1** = Corrediza.

**(NOTA: el submenù de selección se distingue del punto después de la cifra).**

Si es necesario seleccionar otro tipo de automatización, accionar el botón P2 para ver el número correspondiente al tipo de automatización deseada.

Confirmar con P3 (ahora aparecerán los puntos al lado de las cifras).

**Completada la programación seguir el procedimiento para ESC:**

Pulsar **P2** (Adelante) o **P1** (Atrás) hasta ver **ES**

Confirmar con **P3**.

Nota:

CONFIGURACION DE FABRICA	Min/Max	Pre-configurado		
		PS	PF	PL
Velocidad en Apertura Frecuencia en Hz	01 ÷ 99	50Hz	25Hz	50Hz
Velocidad en Cierre Frecuencia en Hz	01 ÷ 99	50Hz	25Hz	50Hz
Velocidad en Apertura Lenta Frecuencia en Hz	01 ÷ 99	25Hz	15Hz	30Hz
Velocidad en Cierre Lenta Frecuencia en Hz	01 ÷ 99	25Hz	15Hz	30Hz

- **Función 02** - Selección tipo de automatización con motor **monofásico** 230Vac

0.1 = PS (Puerta Corrediza/Seccional/Cancela).

0.2 = PF (Puerta Nevera).

0.3 = PL (Puerta a Libro).

#### PROCEDIMIENTO:

Pulsar P3 hasta que en el display aparece primero **EE** después teniendo siempre apretado **0.1**, luego liberar.

Pulsar P2 (Adelante) y aparece **02**

Pulsar otra vez P3 y liberar.

En el Display aparece **0.1** = Corrediza.

**(NOTA: el submenú de selección se distingue del punto después de la cifra).**

Si es necesario seleccionar otro tipo de automatización accionando el botón P2 para ver el número correspondiente al tipo de automatización deseada.

Confirmar con P3.

**Completada la programación seguir el procedimiento para ESC:**

Pulsar P2 (Adelante) o P1 (Atrás) hasta ver **ES**

Confirmar con P3

- **Aprendizaje tiempos de trabajo apertura a cierre**

**⚠ Automation en la posición cerrada y el control de la posición del DIP 4**

#### PROCEDIMIENTO:

- Tener apretado el botón P3 hasta cuando en el display aparezca escrito **EE**
- Pulsar **start**: la automatización iniciará a abrirse
- Pulsar start cuando se desea iniciar el ralentamiento.
- Llegada al fin-carrera de apertura, la automatización se detiene.
- Esperar el tiempo pausa deseado luego pulsar start.
- La automatización inicia el cierre.
- Pulsar start cuando se desea iniciar el ralentamiento.
- Llegada al fin-carrera de cierre, la automatización se detiene.

**NOTA: Durante esta fase, detecta la curva de absorción corriente para la gestión del CONTROL obstáculo, (ampero-stop).**



## • Selección tipo lógica de entrada Start con DIP 4

**⚠** Esto tipo de lógica es ser seleccionado después de autoaprendizaje

- **DIP 4 OFF:** La entrada Start-Open, después de aprender de los tiempos de operación, tiene función de Start. El botón conectado a esta entrada funcionará tanto controlar Abrir que comando de cierre.
- **DIP4 ON:** La entrada Start-Open, después de autoaprendizaje de los tiempos de funcionamiento, asume la función de control de Open. Entonces, el botón conectado a esta entrada, que funcionará igual de comando Abre. En este caso, se debe utilizar para el Comando Cierra, (Close) para volver a cerrar.

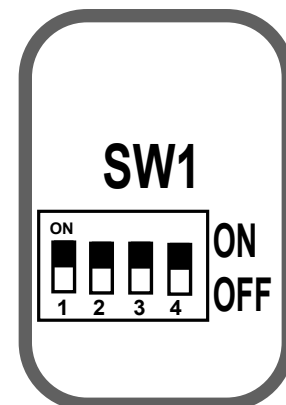

## • Aprendizaje tiempos de trabajo parciales (Peatonal)

- Poner la automatización en posición de cierre.
- Tener apretado el botón P3 hasta que en el display aparece escrito **LE**
- Pulsar start peatonal: la automatización iniciará a abrirse.
- Pulsar start cuando se desea que la automatización se detenga.
- Esperar el tiempo pausa deseado luego pulsar start peatonal.
- La automatización inicia el cierre.
- Llegada al fin-carrera de cierre, la automatización se detiene.

## Función 03 - Modificación tiempo de pausa

- Tener apretado P3 hasta ver en el display escrito **01** y liberar P3
- Pulsar varias veces P2 hasta que en el display aparece **03** .
- Pulsar P3 y en el display aparece **0.4** = 4 segundos de pausa o la configurada en aprendizaje.
- Con el botón P1 aumenta y con el botón P2 se reduce el tiempo en segundos.
- Pulsar P3 para confirmar

**Si no se desea continuar la programación, seguir el procedimiento para ESC:**

Pulsar P2 (Adelante) o P1 (Atrás) hasta ver **ES**

**Confirmar con P3**

## Función 04 - Regulación Par max.

- Pulsar P3 hasta que en el display aparece **01** y liberar el botón
- Pulsar P2 hasta que en el display aparece **04**
- Pulsar P3 en el display aparece **9.9** = a la porcentual del par max configurado.
- Para cambiar pulsar P1 para aumentar o P2 para disminuir.
- Pulsar P3 para confirmar

**Si no se desea continuar la programación, seguir el procedimiento para ESC:**

Pulsar P2 (Adelante) o P1 (Aràs) hasta ver **ES**

**Confirmar con P3**

## **Funciòn 05 – Regulaciòn frecuencia Hz velocidad de trabajo en ABRE**

- Pulsar P3 hasta que en el display aparece **01** y liberar el botòn
- Pulsar P2 hasta que en el display aparece **05**
- Pulsar P3 en el display aparece **5.0** = a la frecuencia configurada.
- Para cambiar pulsar P1 para aumentar o P2 para disminuir hasta la frecuencia deseada
- Pulsar P3 para confirmar.

**Si no se desea continuar la programaciòn, seguir el procedimiento para ESC:**

Pulsar P2 (Adelante) o P1 (Atràs) hasta ver **ES**

**Confirmar con P3**

## **Funciòn 06 – Regulaciòn frecuencia Hz velocidad de trabajo en CIERRE**

- Pulsar P3 hasta que en el display aparece **01** y liberar el botòn
- Pulsar P2 hasta que en el display aparece **06**
- Pulsar P3 en el display aparece **0.5** = a la frecuencia configurada.
- Para cambiar Pulsar P1 para aumentar o P2 para disminuir hasta la frecuencia deseada
- Pulsar P3 para confirmar.

**Si no se desea continuar la programaciòn, seguir el procedimiento para ESC:**

Pulsar P2 (Adelante) o P1 (Atràs) hasta ver **ES**

**Confirmar con P3**

Nota:

<b>CONFIGURACION DE FABRICA</b>	<b>Min/Max</b>	<b>Pre-configurado</b>		
Velocidad en Apertura Frecuencia en Hz	<b>01 ÷ 99</b>	<b>PS</b> 50Hz	<b>PF</b> 25Hz	<b>PL</b> 50Hz
Velocidad en Cierre Frecuencia en Hz	<b>01 ÷ 99</b>	<b>PS</b> 50Hz	<b>PF</b> 25Hz	<b>PL</b> 50Hz
Velocidad en Apertura Lenta Frecuencia en Hz	<b>01 ÷ 99</b>	<b>PS</b> 25Hz	<b>PF</b> 15Hz	<b>PL</b> 30Hz
Velocidad en Cierre Lenta Frecuencia en Hz	<b>01 ÷ 99</b>	<b>PS</b> 25Hz	<b>PF</b> 15Hz	<b>PL</b> 30Hz

## **Funciòn 07 – Regulaciòn frecuencia Hz velocidad reducida en ABRE.**

- Pulsar P3 hasta que en el display aparece **01** y liberar el botòn
- Pulsar P2 hasta que en el display aparece **07**
- Pulsar P3 en el display aparece **3.0** = a la frecuencia configurada.
- Para cambiar pulsar P1 para aumentar o P2 para disminuir hasta la frecuencia deseada
- Premere P3 para confirmar.

**Si no se desea continuar la programaciòn, seguir el procedimiento para ESC:**

Pulsar P2 (Adelante) o P1 (Atràs) hasta ver **ES**

**Confirmar con P3**

## **Función 08 – Regulación frecuencia Hz velocidad reducida en CIERRE**

- Pulsar P3 hasta que en el display aparece **0 l** y liberar el botón
- Pulsar P2 hasta que en el display aparece **08**
- Pulsar P3 en el display aparece **3.0** = a la frecuencia configurada.
- Para cambiar pulsar P1 para aumentar o P2 para disminuir hasta la frecuencia deseada
- Premere P3 para confirmar.

**Si no se desea continuar la programación, seguir el procedimiento para ESC:**

Pulsar P2 (Adelante) o P1 (Atrás) hasta ver **ES**

**Confirmar con P3**

## **Función 09 – Regulación sensibilidad Amperometrica en Abre de 01 a 99**

- Pulsar P3 hasta que en el display aparece **0 l** y liberar el botón
- Pulsar P2 hasta que en el display aparece **09**
- Pulsar P3 en el display aparece **5.0** = al límite d sensibilidad amperometrica configurada.
- Para cambiar Pulsar P1 para aumentar o P2 para disminuir
-  Para inhabilitar el control de la corriente, configurar **0.0**
- **Nota: es. 01= muy sensible – 99= poco sensible**

**Si no se desea continuar la programación, seguir el procedimiento para ESC:**

Pulsar P2 (Adelante) o P1 (Atrás) hasta ver **ES**

**Confirmar con P3**

## **Función 10 – Regulación sensibilidad Amperometrica en Cierre de 01 a 99**

- Pulsar P3 hasta que en el display aparece **0 l** y liberar el botón
- Pulsar P2 hasta que en el display aparece **10**
- Pulsar P3 en el display aparece **5.0** = al límite d sensibilidad amperometrica configurada.
- Para cambiar Pulsar P1 para aumentar o P2 para disminuir
-  Para inhabilitar el control de la corriente, configurar **0.0**
- **Nota: es. 01= muy sensible – 99= poco sensible**

**Si no se desea continuar la programación, seguir el procedimiento para ESC:**

Pulsar P2 (Adelante) o P1 (Atrás) hasta ver **ES**

**Confirmar con P3**

## **Función 11 – Regulación sensibilidad Amperometrica en paro suave Abre de 01 a 99**

- Pulsar P3 hasta que en el display aparece **0 1** y liberar el botón
- Pulsar P2 hasta que en el display aparece **1 1**
- Pulsar P3 en el display aparece **5.0** = al límite de sensibilidad amperometrica configurada.
- Para cambiar Pulsar P1 para aumentar o P2 para disminuir
-  inhabilitar el control de la corriente, configurar **00**
- **Nota: es. 01= muy sensible – 99= poco sensible**

**Si no se desea continuar la programación, seguir el procedimiento para ESC:**

Pulsar P2 (Adelante) o P1 (Atrás) hasta ver **ES**

**Confirmar con P3**

## **Función 12 – Regulación sensibilidad Amperometrica en paro suave en Cierre de 01 a 99**

- Pulsar P3 hasta que en el display aparece **0 1** y liberar el botón
- Pulsar P2 hasta que en el display aparece **1 2**
- Pulsar P3 en el display aparece **5.0** = al límite de sensibilidad amperometrica configurada.
- Para cambiar Pulsar P1 para aumentar o P2 para disminuir
-  inhabilitar el control de la corriente, configurar **00**
- **Nota: es. 01= muy sensible – 99= poco sensible**

**Si no se desea continuar la programación, seguir el procedimiento para ESC:**

Pulsar P2 (Adelante) o P1 (Atrás) hasta ver **ES**

**Confirmar con P3**

## **Funcion 13 – Fuerza inicial de 1 a 20 (Valor expresado en decimas de segundos)**

- Pulsar P3 hasta que en el display aparece **0 1** y suelte el botón
- Pulsar P2 hasta que en el display aparece **1 3**
- Pulsar P3 en el display aparece **0.0** = Discapacitados
- O establecer el tiempo en decimas de segundo
- Pulsar P1 para aumentar o P2 para establecer un tiempo de duracion. Para exp **1.0**
- Pulsar P3 para confirmar.

**Si no se desea continuar la programación, seguir el procedimiento para ESC:**

Pulsar P2 (Adelante) o P1 (Atrás) hasta ver **ES**

**Confirmar con P3**

## **Funcion 14 – Fuerza en final de cierre de 1 a 20 (Valor expresado en decimas de segundos)**

- Pulsar P3 hasta que en el display aparece **01** y liberar el botón
- Pulsar P2 hasta que en el display aparece **14**
- Pulsar P3 en el display aparece **0.0** = Discapacitados
- O establecer el tiempo en decimas de segundo
- Pulsar P1 para aumentar o P2 para establecer un tiempo de duracion. Para exp **1.0**
- Pulsar P3 para confirmar.

**Si no se desea continuar la programación, seguir el procedimiento para ESC:**

Pulsar P2 (Adelante) o P1 (Atràs) hasta ver **ES**

**Confirmar con P3**

## **Funcion 15 – Habilitation funcion de test**

- Pulsar P3 hasta que en el display aparece **01** y liberar el botón
- Pulsar P2 hasta que en el display aparece **15**
- Pulsar P3 en el display aparece **0.0** = Discapacitados
- Establecer el intervalo de tiempo de START en segundos
- Pulsar P1 para aumentar o P2 para establecer un tiempo de duracion. Para exp **3.0**
- Pulsar P3 para confirmar.

**Si no se desea continuar la programación, seguir el procedimiento para ESC:**

Pulsar P2 (Adelante) o P1 (Atràs) hasta ver **ES**

**Confirmar con P3**

## **Funcion 16 – Cuenta Maniobras.**

- Pulsar P3 hasta que en el display aparece **01** y liberar el botón.
- Con el botón P2 correr hasta a **16**
- Pulsar P3 para ver decenas / unidad
- Pulsar P2 para ver unidad-millar / centenas
- Pulsar P2 para ver centenas-millar / decenas-millar
- Pulsar P3 para confirmar

**Si no se desea continuar la programación, seguir el procedimiento para ESC:**

Pulsar P2 (Adelante) o P1 (Atràs) hasta ver **ES**

**Confirmar con P3**

## Selección función hombre presente **UP**

- Pulsar P3 hasta que en el display aparece **01** y liberar el botón
- Pulsar P2 (ADELANTE) o P1 (ATRÁS) hasta que en el display aparece **UP**
- Pulsar P3 para confirmar selección con el boton P2 **Si** o **no**
- Premere P3 para confirmar.

## Significado Dip Switch

**Dip 1 ON** : recierre automático activo

**Dip 1 OFF** : recierre automático excluso

**Dip 2 ON** : inversión en start en cierre activa

**Dip 2 OFF** : inversión en start en cierre exclusa

**Dip 3 ON** : no acepta start en apertura y en abierto

**Dip 3 OFF** : acepta start en apertura y en abierto

**Dip 4 ON** : el botón



Funciona como comando d ABRE

**Dip 4 OFF** : el botón

Funciona como comando de START

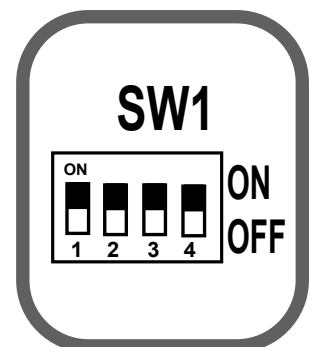

## Posibles Errores señalados en el LED DS1

**E1** Error 1.

**E2** Cortocircuito.

**E3** Setup FF fallada.

**E4** Falta carga capacidad.

**E5** Sobratemperatura.

**E6** Sobracorriente instantánea.

**E7** Sobracorriente retrasada.

**E8** Sobratensión en el bus.

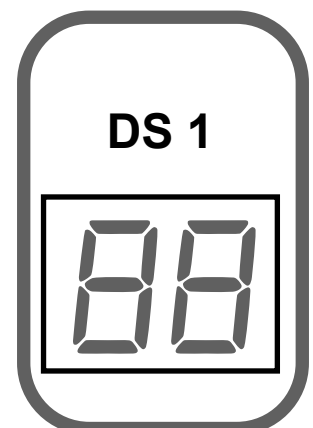

## POSIBLES INDICACIONES EN EL LED DS1

- [H** Portón cerrado.
- [L** Portón en cierre.
- OP** Portón en apertura.
- AP** Portón Abierto.
- tE** Autoaprendizaje.
- St** Stop apretado.
- 01** Motor trifásico 230Vac
- 02** Motor monofásico 230Vac
- 0.1** Corrediza **0.2** Puerta nevera **0.3** Seccional; confirmar con P3
- 03** Regulación tiempo pausa:  
P2 aumenta de 1 segundo,  
P1 decrece de un segundo,  
Confirmar con P3.
- 04** Par max
- 05** Regulación velocidad en ABRE
- 06** Regulación velocidad en CIERRE
- 07** Regulación frecuencia RALENTIZACION ABRE
- 08** Regulación frecuencia RALENTIZACION CIERRE
- 09** Regulación sensibilidad amperimétrica ABRE
- 10** Regulación sensibilidad amperimétrica CIERRE
- 11** Regulación sensibilidad amperimétrica RALENTIZACION ABRE
- 12** Regulación sensibilidad amperimétrica RALENTIZACION CIERRE
- 13** Arranque inicial
- 14** Golpe final
- 15** Habilitar Test
- 16** Cuenta maniobras-Visualización maniobras.
- UP** Funcionamiento solo hombre presente. Si es activo se ve **UP**
- ES** Pulsar P3 para salir de la programación

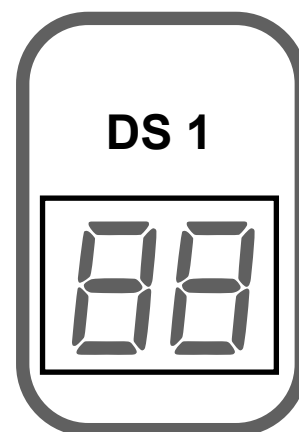



**QUIKO ITALY**

Via Seccalegno, 19  
36040 Sossano (VI) - Italy  
Tel. +39 0444 785513  
Fax +39 0444 782371  
**info@quiko.biz**  
**www.quikoitaly.com**

**DECLARACIÓN DE CONFORMIDAD**

El fabricante asegura que el dispositivo cumple con los requisitos esenciales de seguridad de las directivas:

- Los equipos de radio - 1999/5 / CE;
- Baja Tensión - 73/23 / CEE, 93/68 / CEE del Consejo (EN 60335-1 (1998));
- Compatibilidad electromagnética - 89/336 / CEE, 93/68 / CEE, 98/37 / CE (EN 50081-1, EN 50081-2, EN 61000-3-2, EN 61000-3-2 / A1, EN 61000-3-2 / A2, EN 61000-3-2 / A14, EN61000-3-3, EN 61000-6-2, ETSI EN 300220-3, ETSI EN 301.489-3, ETSI EN 301489 hasta 1)

Así como sus modificaciones y actualizaciones, así como las disposiciones que implementan su asimilación en el sistema jurídico nacional del país de destino y la utilización del coche.





# MANUALE D'ISTRUZIONE

## V01/2019

Apparecchiatura di comando  
ad INVERTER

# QK-CE220RLINV

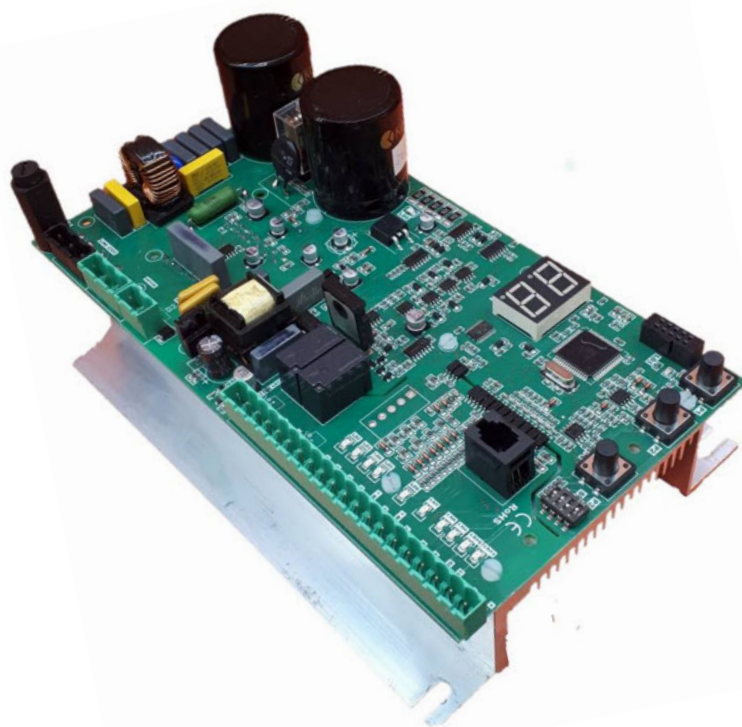

Per automazioni Industriali  
Alimentazione monofase 230Vac  
Uscita motore trifase 230Vac



**ATTENZIONE!!** Prima di effettuare l'installazione, leggere attentamente questo manuale. La QUIKO declina ogni responsabilità in caso di non osservanza delle normative vigenti.

**qui>lö**<sup>®</sup>  
opening solutions

## Caratteristiche principali :

- Frequenza di lavoro apre e chiude regolabili separatamente
- Rampa accelerazione/ decelerazione e velocità in rallentamento regolabili
- Amperometrica con sensibilità ostacolo regolabile sia in apertura che in chiusura
- Logica di inversione ostacolo regolabile sia in apertura che in chiusura.
- Ingresso per costa di sicurezza NC/8.2 kohm
- Ingressi per fotocellula-sicurezza in apertura e chiusura
- Ingressi di Apre/Chiude/Parziale e Passo-Passo
- Programmi di funzionamento: automatico, semi-automatico o uomo presente selezionabili
- Visualizzazione stato ingressi e assegnazione funzione tramite menu a display
- Ricevitore innesto opzionale per la gestione di trasmettitori a codice fisso o Rolling-code

## Descrizione Generale

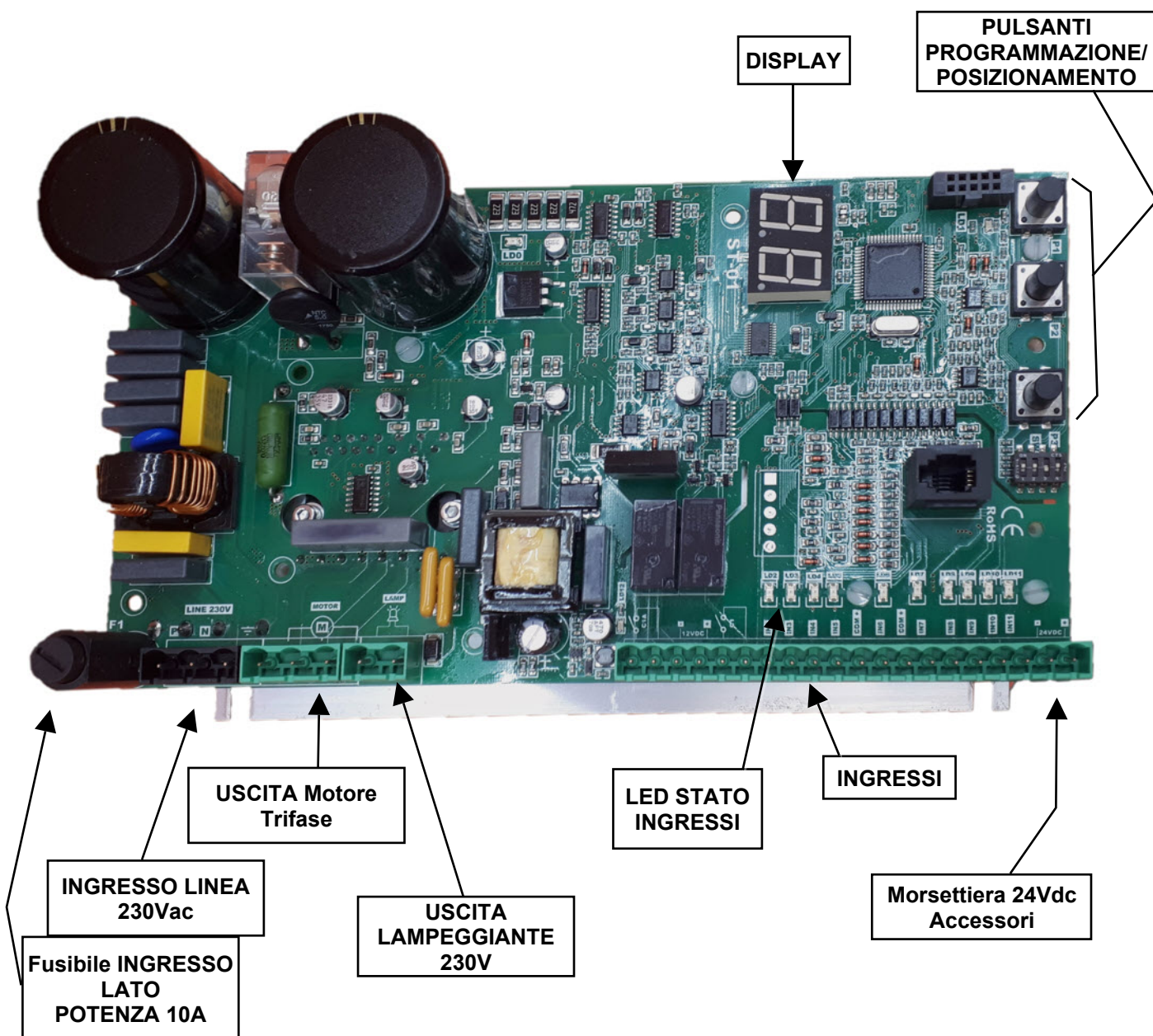

## Caratteristiche generali :

- ☒ Programmazione e auto apprendimento tramite tasti (incremento, decremento, convalida) ed un display a due cifre
- ☒ Gestione di tre sicurezze di cui: una fotocellula, una sicurezza in chiusura ed una in apertura.
- ☒ Contatto pulito per segnalazione stato automazione/allarme
- ☒ Contatto 12Vac per controllo alimentazione sicurezze/funzioni ausiliarie

- ☒ Morsetti di potenza e di segnale estraibili
- ☒ Predisposta per accoppiamento con filtro di rete
- ☒ Conforme alle Direttive Europee di riferimento:  
Bassa Tensione 73/23/CEE  
Compatibilità Elettromagnetica (EMC) 89/336/CEE  
(N.B. : solo se installato filtro di rete o equivalenti)



FILTRO

## Caratteristiche tecniche :

Alimentazione	230Vac
Uscita motore	Trifase 230 VAC – Monofase 230 Vac
Collegamento motore Trifase	A Triangolo
Collegamento motore Monofase	No condensatore
Potenza motore	2HP
Temp. funzionamento	-20°C / + 55 °C
Alimentazione accessori	12-24 VDC/AC – 4 Watt Per potenze superiori installare trasformatore esterno

## Protezioni :

- ☒ Motore protetto da fusibile e da controllo elettronico
- ☒ Circuiti di potenza protetti elettronicamente e tramite varistori.
- ☒ Secondario trasformatore, protetto da fusibile auto ripristinante e transil.
- ☒ Condensatori di filtro su ingresso rete

# Collegamento MOTORE/LAMPEGGIANTE/ COMANDI SICUREZZE

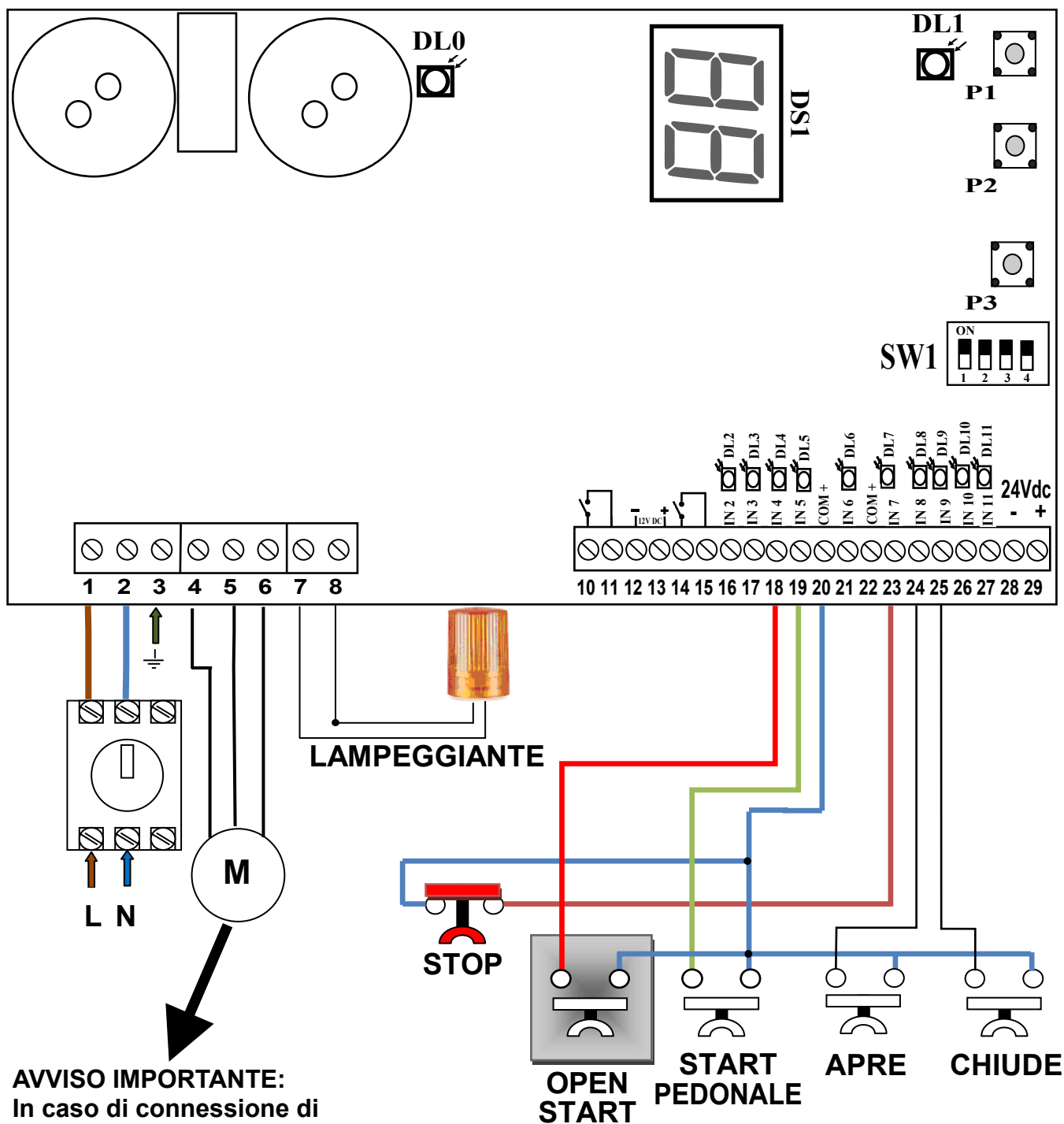

**AVVISO IMPORTANTE:**  
 In caso di connessione di motoriduttore 230V monofase, non deve essere utilizzato il condensatore.

# Collegamento DISPOSITIVI DI SICUREZZA

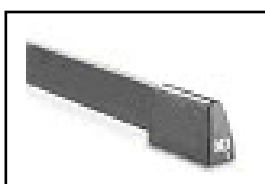
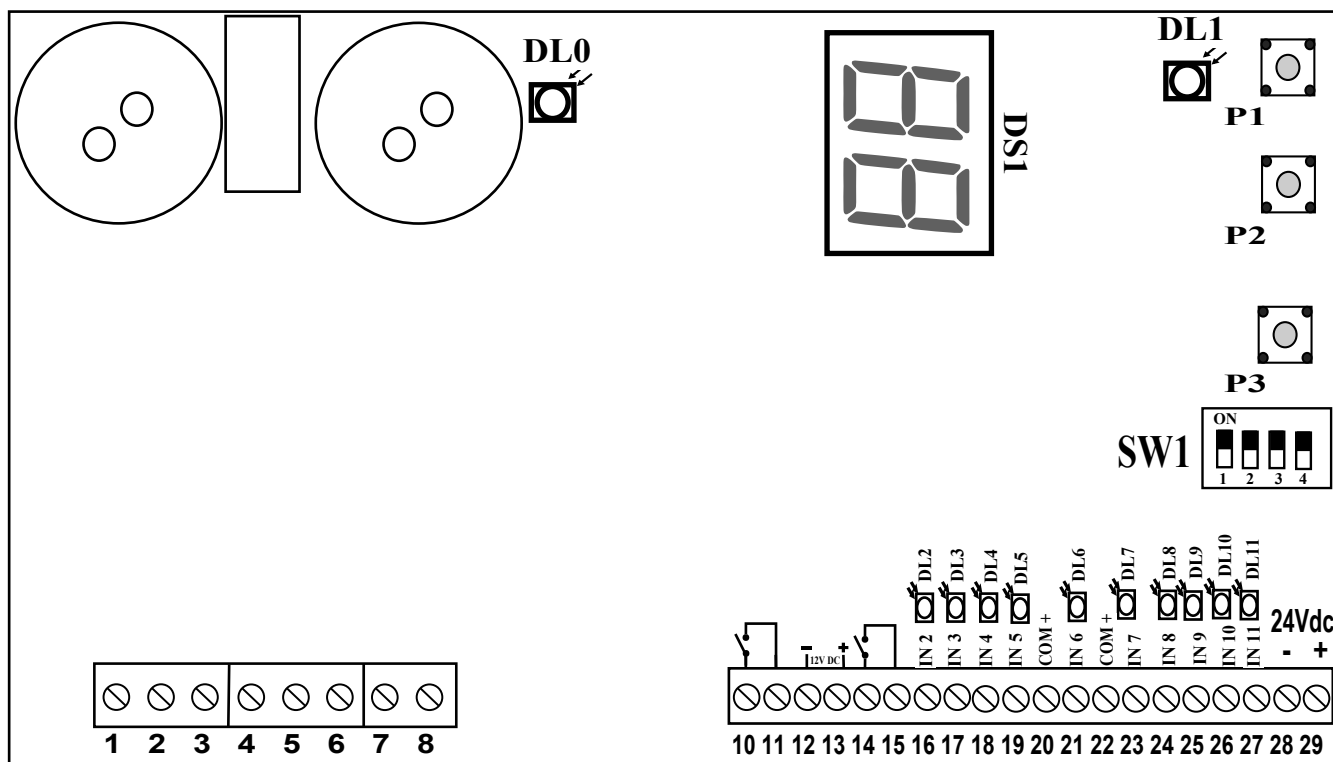



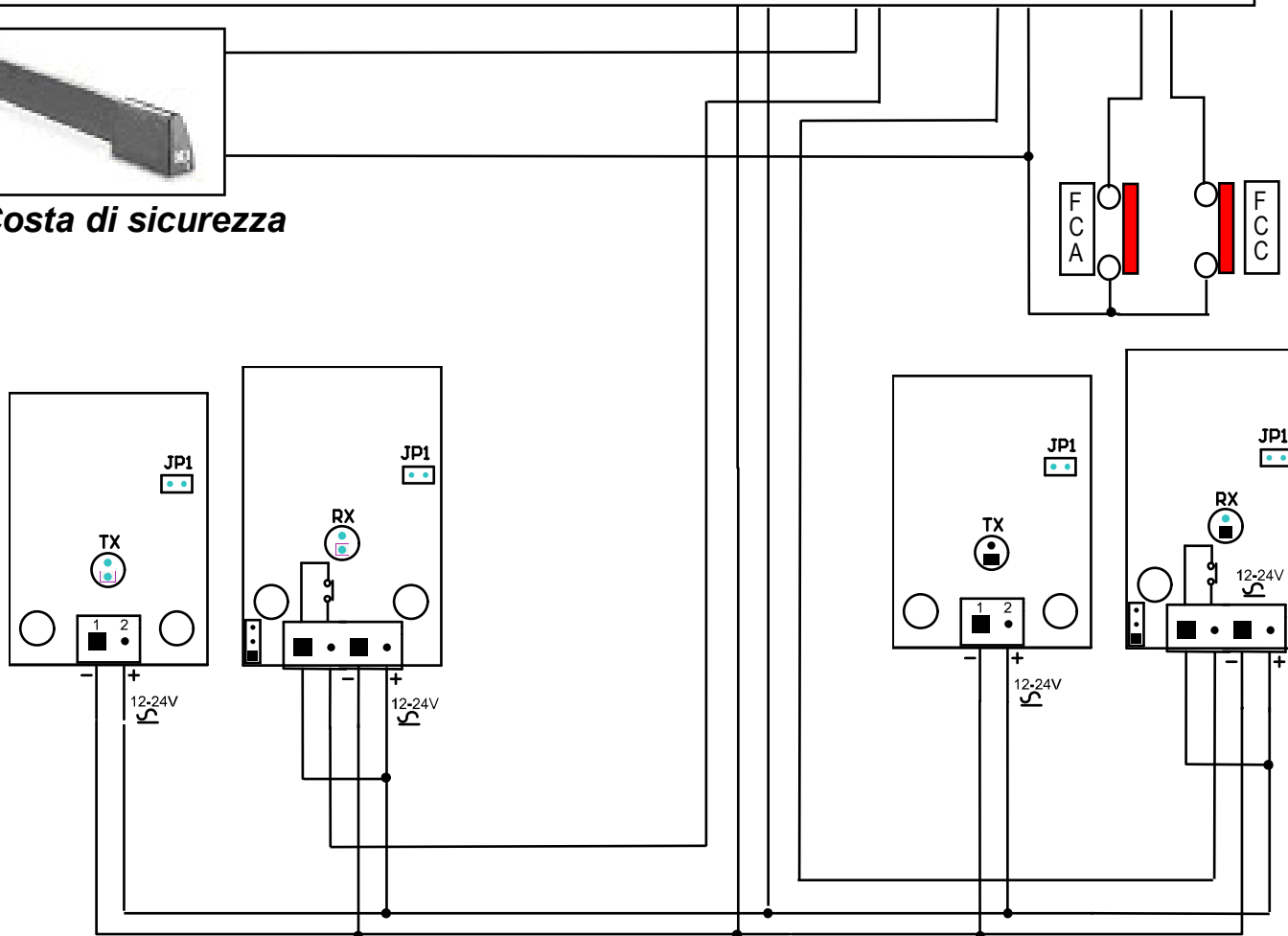



**Costa di sicurezza**



**Barriera/Costa in apertura**

**Fotocellula di sicurezza**

## Numerazione MORSETTIERA/significato LED :

	<b>1</b>	<b>INGRESSO FASE Alimentazione 230Vac</b>
	<b>2</b>	<b>INGRESSO NEUTRO Alimentazione 230Vac</b>
	<b>3</b>	<b>INGRESSO TERRA Alimentazione 230Vac</b>
	<b>4</b>	<b>USCITA FASE 1 motore</b>
	<b>5</b>	<b>USCITA FASE 2 motore</b>
	<b>6</b>	<b>USCITA FASE 3 motore</b>
	<b>7</b>	<b>USCITA lampeggiante 230V</b>
	<b>8</b>	<b>COMUNE lampeggiante</b>

**LD 0**

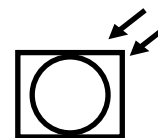







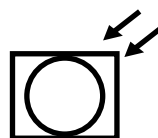











**Led indicazione scarica condensatori.**











Dopo aver tolto alimentazione, attendere che LD0 si spenga prima di intervenire sulla centralina.

**LD 1**



**Led attività microcontrollore**

	<b>10</b>	<b>USCITA contatto pulito NA</b>
	<b>11</b>	
	<b>12</b>	<b>USCITA - 12Vdc accessori</b>
	<b>13</b>	<b>USCITA + 12Vdc accessori (COMUNE)</b>
	<b>14</b>	<b>USCITA contatto pulito NA</b>
	<b>15</b>	
	<b>16</b>	<b>INGRESSO costa di sicurezza</b>
	<b>17</b>	<b>INGRESSO barriera / costa in apertura</b>
	<b>18</b>	<b>INGRESSO START</b>
	<b>19</b>	<b>INGRESSO START PEDONALE</b>
	<b>20</b>	<b>COMUNE ingressi 12Vdc</b>
	<b>21</b>	<b>INGRESSO FOTOCELLULA SICUREZZA</b>
	<b>22</b>	<b>COMUNE ingressi 12Vdc</b>
	<b>23</b>	<b>INGRESSO STOP</b>
	<b>24</b>	<b>INGRESSO APRE</b>
	<b>25</b>	<b>INGRESSO CHIUDE</b>
	<b>26</b>	<b>INGRESSO FINECORSAPRE</b>
	<b>27</b>	<b>INGRESSO FINECORSACHIUDE</b>
	<b>28</b>	<b>USCITA - 24Vdc accessori</b>
	<b>29</b>	<b>USCITA + 24Vdc accessori</b>

	LD2
	LD3
	LD4
	LD5
	LD6
	LD7
	LD8
	LD9
	LD10
	LD11

## Settaggi e programmazione :

### • Verifica senso di rotazione motore

Terminati i collegamenti, a motore sbloccato, posizionare la porta fuori dal fine corsa di chiusura, bloccare il motore e dare alimentazione al quadro elettrico.

Utilizzare tastini a bordo aventi le seguenti funzioni:

**P1** tasto **CHIUDE**

**P2** tasto **APRE**

**P3** tasto **CONFERMA/SELEZIONE FASE PROGRAMMAZIONE**

- Verificare che premendo il tasto P1 la porta chiuda e portarla fino alla posizione di chiuso, verificare che LD11 si spenga.
- In caso contrario invertire SOLO 2 delle 3 fasi motore.

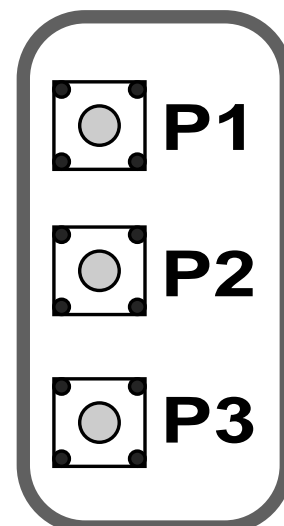

- Verificare che sul display DS1 venga visualizzata la scritta **[H = Portone chiuso**

- Verificare che il led LD11 relativo a FCC sia spento

- **Funzione 01** - Selezione tipo di automazione con motore trifase 230Vac

**0.1** = PS (Porta Scorrevole/Sezionale/Cancello).

**0.2** = PF (Porta Frigo).

**0.3** = PL (Porta a Libro).

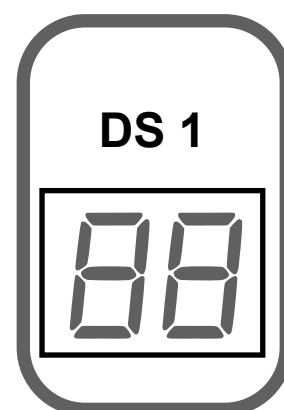

### PROCEDURA:

Premere P3 fino a che sul display appare **0.1** e rilasciare.

Premere nuovamente P3 e rilasciare.

Sul Display appare **0.1** = Scorrevole.

**(NOTA: il sottomenù di selezione si distingue dal punto dopo la cifra).**

Se necessario selezionare altro tipo di automazione, agire sul tasto P2 per visualizzare il numero corrispondente al tipo di automazione desiderata.

Confermare con P3 (a questo punto scompariranno i puntini a fianco delle cifre).

**Terminata la programmazione seguire la procedura per ESC:**

Premere **P2** (Avanti) o **P1** (Indietro) fino a visualizzare **ES**

Confermare con **P3**.

Nota:

IMPOSTAZIONE DI FABBRICA	Min/Max	Pre-impostato		
		PS	PF	PL
Velocità in Apertura Frequenza in Hz	01 ÷ 99	50Hz	25Hz	50Hz
Velocità in Chiusura Frequenza in Hz	01 ÷ 99	50Hz	25Hz	50Hz
Velocità in Apertura Rallentata Frequenza in Hz	01 ÷ 99	25Hz	15Hz	30Hz
Velocità in Chiusura Rallentata Frequenza in Hz	01 ÷ 99	25Hz	15Hz	30Hz

- **Funzione 02** - Selezione tipo di automazione con motore **monofase** 230Vac

**0.1** = **PS** (Porta Scorrevole/Sezionale/Cancello).

**0.2** = **PF** (Porta Frigo).

**0.3** = **PL** (Porta a Libro).

#### PROCEDURA:

Premere P3 fino a che sul display appare prima **EE** e poi tenendo sempre premuto **0.1**, quindi rilasciare.

Premere P2 (Avanti) e appare **02**

Premere nuovamente P3 e rilasciare.

Sul Display appare **0.1** = Scorrevole.

**(NOTA: il sottomenù di selezione si distingue dal punto dopo la cifra).**

Se necessario selezionare altro tipo di automazione agendo sul tasto P2 per visualizzare il numero corrispondente al tipo di automazione desiderata.

Confermare con P3.

**Terminata la programmazione seguire la procedura per ESC:**

Premere P2 (Avanti) o P1 (Indietro) fino a visualizzare **ES**

Confermare con P3.

- **Apprendimento tempi di lavoro apertura a chiusura**

**⚠ Automazione in posizione di chiuso e verifica della posizione del DIP 4**

#### PROCEDURA:

- Tenere premuto il tasto P3 fino a quando sul display compare la scritta **EE**
- Premere **start**: l'automazione partirà in apertura
- Premere start quando si vuole che inizi il rallentamento.
- Arrivata sul finecorsa di apertura, l'automazione si ferma.
- Attendere il tempo sosta desiderato quindi premere start.
- L'automazione parte in chiusura.
- Premere start quando si vuole che inizi il rallentamento.
- Arrivata sul finecorsa di chiusura, l'automazione si ferma.

**NOTA: Durante questa fase, rileva la curva di assorbimento correnti per la gestione del CONTROLLO ostacolo, (ampero-stop).**



## • Selezione Tipo di logica ingresso Start con DIP 4

**⚠** Questo tipo di logica è da selezionare dopo l'Autoapprendimento

- **DIP4 in OFF** : L'ingresso **Start-Open**, dopo l'Autoapprendimento dei tempi di manovra, assume la funzione di Start. Quindi il tasto collegato a questo ingresso funzionerà sia da comando Apre che da comando chiude.
- **DIP4 in ON** : L'ingresso **Sart-Open**, dopo l'auto apprendimento dei tempi di manovra, assume la funzione di comando Apre, sia impulsivo che a Uomo Presente. Quindi, il pulsante collegato a questo ingresso, funzionerà solo come comando Apre. In questo caso, dovrà essere utilizzato il Comando Chiude, (Close) per la richiusura.

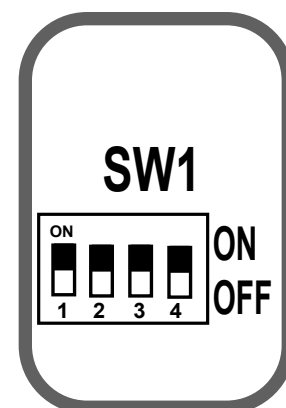

## • Apprendimento tempi di lavoro parziali (Pedonale)

- Posizionare l'automazione in posizione di chiuso.
- Tenere premuto il pulsante P3 fino a quando sul display compare la scritta **LE**
- Premere start pedonale: l'automazione partirà in apertura.
- Premere start pedonale quando si vuole che l'automazione si fermi.
- Attendere il tempo sosta desiderato quindi premere start pedonale.
- L'automazione parte in chiusura.
- Arrivata sul fincorsa di chiusura, l'automazione si ferma.

## Funzione 03 - Modifica tempo di sosta

- Tenere premuto P3 fino a visualizzare su display la scritta **01** e rilasciare P3
- Premere più volte P2 fino a che sul display appare **03** .
- Premere P3 e sul display appare **0.4** = 4 secondi di sosta o quella impostata in apprendimento.
- Con il tasto P1 aumenta e con il tasto P2 diminuisce il tempo in secondi
- Premere P3 per conferma

**Se non si desidera proseguire la programmazione, seguire la procedura per ESC:**

Premere P2 (Avanti) o P1 (Indietro) fino a visualizzare **ES**

**Confermare con P3.**

## Funzione 04 – Regolazione Coppia max.

- Premere P3 fino a che sul display appare **01** e rilasciare il tasto
- Premere P2 fino a che sul display appare **04**
- Premere P3 sul display appare **9.9** = alla percentuale della coppia max impostata.
- Per modifica premer P1 per aumentare o P2 per diminuire.
- Premer P3 per conferma

**Se non si desidera proseguire la programmazione, seguire la procedura per ESC:**

Premere P2 (Avanti) o P1 (Indietro) fino a visualizzare **ES**

**Confermare con P3.**

## Funzione 05 - Regolazione frequenza Hz velocità di lavoro in APRE

- Premere P3 fino a che sul display appare **01** e rilasciare il tasto
- Premere P2 fino a che sul display appare **05**
- Premere P3 sul display appare **5.0** = alla frequenza impostata.
- Per modifica premere P1 per aumentare o P2 per diminuire fino alla frequenza desiderata
- Premere P3 per conferma.

**Se non si desidera proseguire la programmazione, seguire la procedura per ESC:**

Premere P2 (Avanti) o P1 (Indietro) fino a visualizzare **ES**

**Confermare con P3.**

## Funzione 06 - Regolazione frequenza Hz velocità di lavoro in CHIUDE

- Premere P3 fino a che sul display appare **01** e rilasciare il tasto
- Premere P2 fino a che sul display appare **06**
- Premere P3 sul display appare **5.0** = alla frequenza impostata.
- Per modifica premere P1 per aumentare o P2 per diminuire fino alla frequenza desiderata
- Premere P3 per conferma.

**Se non si desidera proseguire la programmazione, seguire la procedura per ESC:**

Premere P2 (Avanti) o P1 (Indietro) fino a visualizzare **ES**

**Confermare con P3.**

Nota:

IMPOSTAZIONE DI FABBRICA	Min/Max	Pre-impostato		
Velocità in Apertura Frequenza in Hz	01 ÷ 99	PS 50Hz	PF 25Hz	PL 50Hz
Velocità in Chiusura Frequenza in Hz	01 ÷ 99	PS 50Hz	PF 25Hz	PL 50Hz
Velocità in Apertura Rallentata Frequenza in Hz	01 ÷ 99	PS 25Hz	PF 15Hz	PL 30Hz
Velocità in Chiusura Rallentata Frequenza in Hz	01 ÷ 99	PS 25Hz	PF 15Hz	PL 30Hz

## Funzione 07 – Regolazione frequenza Hz velocità di rallentamento in APRE.

- Premere P3 fino a che sul display appare **01** e rilasciare il tasto
- Premere P2 fino a che sul display appare **07**
- Premere P3 sul display appare **3.0** = alla frequenza impostata.
- Per modifica premere P1 per aumentare o P2 per diminuire fino alla frequenza desiderata
- Premere P3 per conferma.

**Se non si desidera proseguire la programmazione, seguire la procedura per ESC:**

Premere P2 (Avanti) o P1 (Indietro) fino a visualizzare **ES**

**Confermare con P3**

## Funzione 08 – Regolazione frequenza Hz velocità di rallentamento in CHIUDE

- Premere P3 fino a che sul display appare **01** e rilasciare il tasto
- Premere P2 fino a che sul display appare **08**
- Premere P3 sul display appare **3.0** = alla frequenza impostata.
- Per modifica premere P1 per aumentare o P2 per diminuire fino alla frequenza desiderata
- Premere P3 per conferma.

**Se non si desidera proseguire la programmazione, seguire la procedura per ESC:**

**Premere P2 (Avanti) o P1 (Indietro) fino a visualizzare **ES****

**Confermare con P3.**

## Funzione 09 – Regolazione sensibilità Amperometrica in Apre da 01 a 99

- Premere P3 fino a che sul display appare **01** e rilasciare il tasto
- Premere P2 fino a che sul display appare **09**
- Premere P3 sul display appare **5.0** = alla soglia di sensibilità amperometrica impostata.
- Per modifica premere P1 per aumentare o P2 per diminuire
-  Per disabilitare il controllo della corrente, impostare **00**
- **Nota: es. 01= molto sensibile – 99= poco sensibile.**

**Se non si desidera proseguire la programmazione, seguire la procedura per ESC:**

**Premere P2 (Avanti) o P1 (Indietro) fino a visualizzare **ES****

**Confermare con P3**

## Funzione 10 – Regolazione sensibilità Amperometrica in Chiude da 01 a 99

- Premere P3 fino a che sul display appare **01** e rilasciare il tasto
- Premere P2 fino a che sul display appare **10**
- Premere P3 sul display appare **5.0** = alla soglia di sensibilità amperometrica impostata.
- Per modifica premere P1 per aumentare o P2 per diminuire
-  Per disabilitare il controllo della corrente, impostare **00**
- **Nota: es. 01= molto sensibile – 99= poco sensibile.**

**Se non si desidera proseguire la programmazione, seguire la procedura per ESC:**

**Premere P2 (Avanti) o P1 (Indietro) fino a visualizzare **ES****

**Confermare con P3**

## Funzione 11 – Regolazione sensibilità Amperometrica in Rallentamento Apre da 01 a 99

- Premere P3 fino a che sul display appare **01** e rilasciare il tasto
- Premere P2 fino a che sul display appare **11**
- Premere P3 sul display appare **5.0** = alla soglia di sensibilità amperometrica impostata.
- Per modifica premere P1 per aumentare o P2 per diminuire
-  Per disabilitare il controllo della corrente, impostare **00**
- **Nota: es. 01= molto sensibile – 99= poco sensibile.**

**Se non si desidera proseguire la programmazione, seguire la procedura per ESC:**

Premere P2 (Avanti) o P1 (Indietro) fino a visualizzare **ES**

**Confermare con P3**

## Funzione 12 – Regolazione sensibilità Amperometrica in Rallentamento Chiude da 01 a 99

- Premere P3 fino a che sul display appare **01** e rilasciare il tasto
- Premere P2 fino a che sul display appare **12**
- Premere P3 sul display appare **5.0** = alla soglia di sensibilità amperometrica impostata.
- Per modifica premere P1 per aumentare o P2 per diminuire
-  Per disabilitare il controllo della corrente, impostare **00**
- **Nota: es. 01= molto sensibile – 99= poco sensibile.**

**Se non si desidera proseguire la programmazione, seguire la procedura per ESC:**

Premere P2 (Avanti) o P1 (Indietro) fino a visualizzare **ES**

**Confermare con P3**

## Funzione 13 – Spunto Iniziale da 1 a 20 (Valore espresso in decimi di secondo)

- Premere P3 fino a che sul display appare **01** e rilasciare il tasto
- Premere P2 fino a che sul display appare **13**
- Premere P3 sul display appare **0.0** = Disabilitato.
- Oppure, impostare il tempo in decimi di secondo
- Premere P1 per aumentare o P2 per impostare un tempo di durata. Es. ( **1.0** )
- Premere P3 per conferma.

**Se non si desidera proseguire la programmazione, seguire la procedura per ESC:**

Premere P2 (Avanti) o P1 (Indietro) fino a visualizzare **ES**

**Confermare con P3**

## **Funzione 14 – Colpo Finale in chiusura dopo Fine Corsa da 1 a 20 (Valore espresso in decimi di secondo)**

- Premere P3 fino a che sul display appare **01** e rilasciare il tasto
- Premere P2 fino a che sul display appare **14**
- Premere P3 sul display appare **0.0** = Disabilitato.
- Oppure, impostare il tempo in decimi di secondo
- Premere P1 per aumentare o P2 per impostare un tempo di durata. Es. ( **1.0** )
- Premere P3 per conferma.

**Se non si desidera proseguire la programmazione, seguire la procedura per ESC:**

Premere P2 (Avanti) o P1 (Indietro) fino a visualizzare **ES**

**Confermare con P3**

## **Funzione 15 – Abilitazione Funzione Test**

- Premere P3 fino a che sul display appare **01** e rilasciare il tasto
- Premere P2 fino a che sul display appare **15**
- Premere P3 sul display appare **0.0** = Disabilitato.
- Oppure, impostare il tempo di intervallo di Start in secondi
- Premere P1 per aumentare o P2 per impostare un tempo di intervallo start. Es. ( **3.0** )
- Premere P3 per conferma.

**Se non si desidera proseguire la programmazione, seguire la procedura per ESC:**

Premere P2 (Avanti) o P1 (Indietro) fino a visualizzare **ES**

**Confermare con P3**

## **Funzione 16 – Conta Manovre.**

- Premere P3 fino a che sul display appare **01** e rilasciare il tasto.
- Con il tasto P2 scorrere fino a **16**
- Premere P3 per visualizzare decine / unità
- Premere P2 per migliaia / centinaia
- Premere P2 per centi-migliaia / decine-migliaia
- Premere P3 per conferma

**Se non si desidera proseguire la programmazione, seguire la procedura per ESC:**

Premere P2 (Avanti) o P1 (Indietro) fino a visualizzare **ES**

**Confermare con P3**

## Selezione funzione uomo presente *UP*

- Premere P3 fino a che sul display appare *01* e rilasciare il tasto.
- Premere P2 (AVANTI) o P1 (INDIETRO) fino a che sul display appare *UP*
- Premere P3 per confermare e selezionare con P2 *Si* o *no*
- Premere P3 per confermare.

## Significato Dip Switch

**Dip 1 ON** : richiusura automatica inserita

**Dip 1 OFF** : richiusura automatica esclusa

**Dip 2 ON** : inversione su start in chiusura inserita

**Dip 2 OFF** : inversione su start in chiusura esclusa

**Dip 3 ON** : non accetta start in apertura ed in aperto

**Dip 3 OFF** : accetta start in apertura ed in aperto

**Dip 4 ON** : il tasto  Funziona come comando di APRE

**Dip 4 OFF** : il tasto  Funziona come comando di START

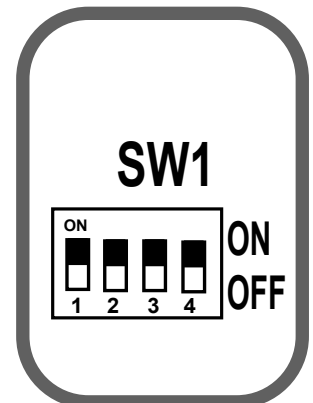

## Possibili Errori segnalati su LCD DS1

**E1** Errore 1.

**E2** Cortocircuito.

**E3** Setup FF fallito.

**E4** Mancata carica capacità.

**E5** Sovratemperatura.

**E6** Sovracorrente istantanea.

**E7** Sovracorrente ritardata.

**E8** Sovratensione sul bus.

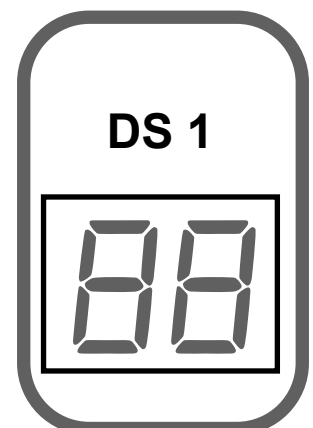

## Possibili indicazioni su LCD DS1

- [H** Portone chiuso.
- [L** Portone in chiusura.
- OP** Portone in apertura.
- AP** Portone Aperto.
- tE** Autoapprendimento.
- St** Stop premuto.
- 0 1** Motore **trifase** 230Vac
- 02** Motore **monofase** 230Vac
- 0. 1** Scorrevole **0.2** Porta frigo **0.3** Sezionale; confermare con P3.
- 03** Regolazione tempo sosta:  
P2 incrementa di 1 secondo,  
P1 decrementa di un secondo,  
Confermare con P3.
- 04** Coppia max
- 05** Regolazione frequenza APRE
- 06** Regolazione frequenza CHIUDE
- 07** Regolazione frequenza RALLENTAMENTO APRE
- 08** Regolazione frequenza RALLENTAMENTO CHIUDE
- 09** Sensibilità amperometrica Apre
- 10** Sensibilità amperometrica Chiude
- 11** Sensibilità amperometrica rallentamento Apre
- 12** Sensibilità amperometrica rallentamento Chiude
- 13** Spunto iniziale
- 14** Colpo finale in chiusura
- 15** Abilitazione Test
- 16** Visualizzazione numero di manovre
- UP** Funzionamento solo uomo presente. Se attivato viene visualizzato **UP**.
- ES** Premere P3 per uscire dalla programmazione.

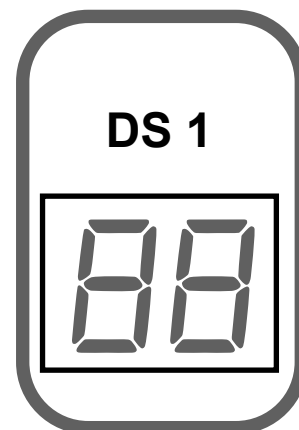



**QUIKO ITALY**

Via Seccalegno, 19  
36040 Sossano (VI) - Italy  
Tel. +39 0444 785513  
Fax +39 0444 782371  
**info@quiko.biz**  
**www.quikoitaly.com**

**DICHIARAZIONE DI CONFORMITA**

Il costruttore dichiara che il dispositivo è conforme ai requisiti essenziali di sicurezza delle direttive:

- Apparecchiature Radio - **1999/5/CE**;
- Bassa Tensione - **73/23/CEE, 93/68/CEE** (EN 60335-1 (1998));
- Compatibilità Elettromagnetica - **89/336/CEE, 93/68/CEE, 98/37/CE** (EN 50081-1, EN 50081-2, EN 61000-3-2, EN 61000-3-2/A1, EN 61000-3-2/A2, EN 61000-3-2/A14, EN 61000-3-3, EN 61000-6-2, ETSI EN 300220-3, ETSI EN 301489-3, ETSI EN 301489-1), nonché alle loro modificazioni e aggiornamenti, e alle disposizioni che ne attuano il recepimento all'interno dell'Ordinamento Legislativo Nazionale del paese di destinazione e utilizzo della macchina.

