

QK-DMKEY1 QK-KEY1

Waterproof Keypad/Reader/Controller

User Manual

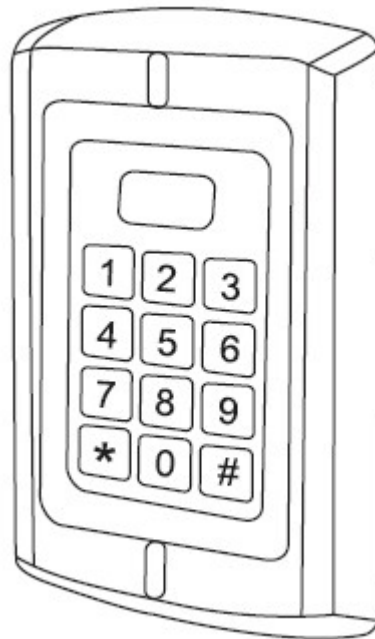

1. Packing List

Name	Quantity	Remarks
Digital Keypad QK-DMKEY1	1	
User manual	1	
Screw driver	1	
Rubber bungs	4	6*27mm, used for fixing
Self tapping screws	4	3.5*27mm, used for fixing
Manager Card	2	Manager Add Card & Manager Delete Card

Please ensure that all the above contents are correct. If any are missing please notify the supplier of the QK-DMKEY1.

2. Description

The QK-DMKEY1 is single door multifunction standalone access controller or a Wiegand output keypad or card reader. It is suitable for mounting either indoor or outdoor in harsh environments. It is housed in a strong, sturdy and vandal proof Zinc Alloy electroplated case. The electronics are fully potted so the QK-DMKEY1 is waterproof and conforms to IP68.

The QK-DMKEY1 supports up to 2000 users in either a Card, 4~8 digits PIN, or a Card + PIN option. The built-in card reader supports EM 125KHZ frequency cards/tags. The QK-DMKEY1 has many extra features including block enrollment, Wiegand 26 bits interface, and backlit keypad.

These features make QK-DMKEY1 an ideal choice for door access not only for small shops and domestic households but also for commercial and industrial applications such as factories, warehouses, laboratories, banks and prisons.

3. Features

- Waterproof, conforms to IP68
- Strong Zinc Alloy Electroplated anti-vandal case
- Full programming from the keypad
- 2,000 users, supports Card, PIN, Card + PIN
- Can be used as a stand alone keypad, Pin length 4~8 digits
- Backlight keypad
- Wiegand 26 bit input & output
- One programmable Relay output, NO, NC, COM
- Adjustable Door Output time, Alarm time, Door Open time
- Block enrollment, can enroll maximum 2000 consecutive card within 2 minutes
- Very low power consumption (< 60mA)
- Easy to install and program

- Built in light dependent resistor (LDR) for anti tamper
- Built in buzzer
- Red, Yellow and Green LEDs display the working status
- 12~24VDC – 12-18VAC
- Two-year warranty

4. Specifications

Operating Voltage	12~24V DC – 12-18V AC
User Capacity	2,000
Keypad	12 keys, 3 x 4 digits
Card Type	EM 125 KHZ card
Card Reading Distance	3~6 cm
Active Current	< 80mA
Idle Current	≤40mA
Lock Output Load	Max 2A
Alarm Output Load	Max 20mA
Operating Temperature	-20~60°C
Operating Humidity	5%~95% RH
Environment	Conforms to IP68
Adjustable Door Relay time	0 ~ 99 seconds
Adjustable Alarm Time	0 ~ 3 minutes
Wiegand Interface	Wiegand 26 input & output
Wiring Connections	Electric Lock, Exit Button, DOTL, External Alarm
Dimensions	L128 x W82 x H28 mm
Net Weight	550 g
Gross Weight	700 g

5. Installation

- Remove the back cover from the keypad using the supplied security screwdriver
- Drill 4 holes on the wall for the screws and 1 hole for the cable
- Fix the back cover firmly on the wall with 4 flat head screws
- Thread the cable through the cable hole
- Attach the keypad to the back cover.

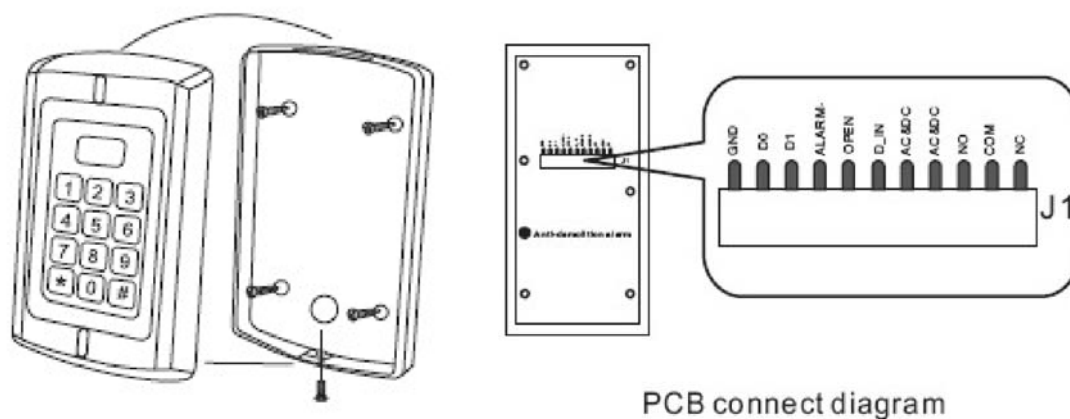

6. Wiring

Color	Function	Description
Green	D0	Wiegand Output D0
White	D1	Wiegand Output D1
Grey	Alarm -	Alarm Negative
Yellow	OPEN	Request to Exit Button
Brown	D-In	Door Contact
Red	Power supply	Regulated Power Input
Black	Power supply	Regulated Power Input
Blue	NO	Relay NO
Purple	COM	Relay COM
Orange	NC	Relay NC
Pink	GND	External Reader Negative

Connection Diagram

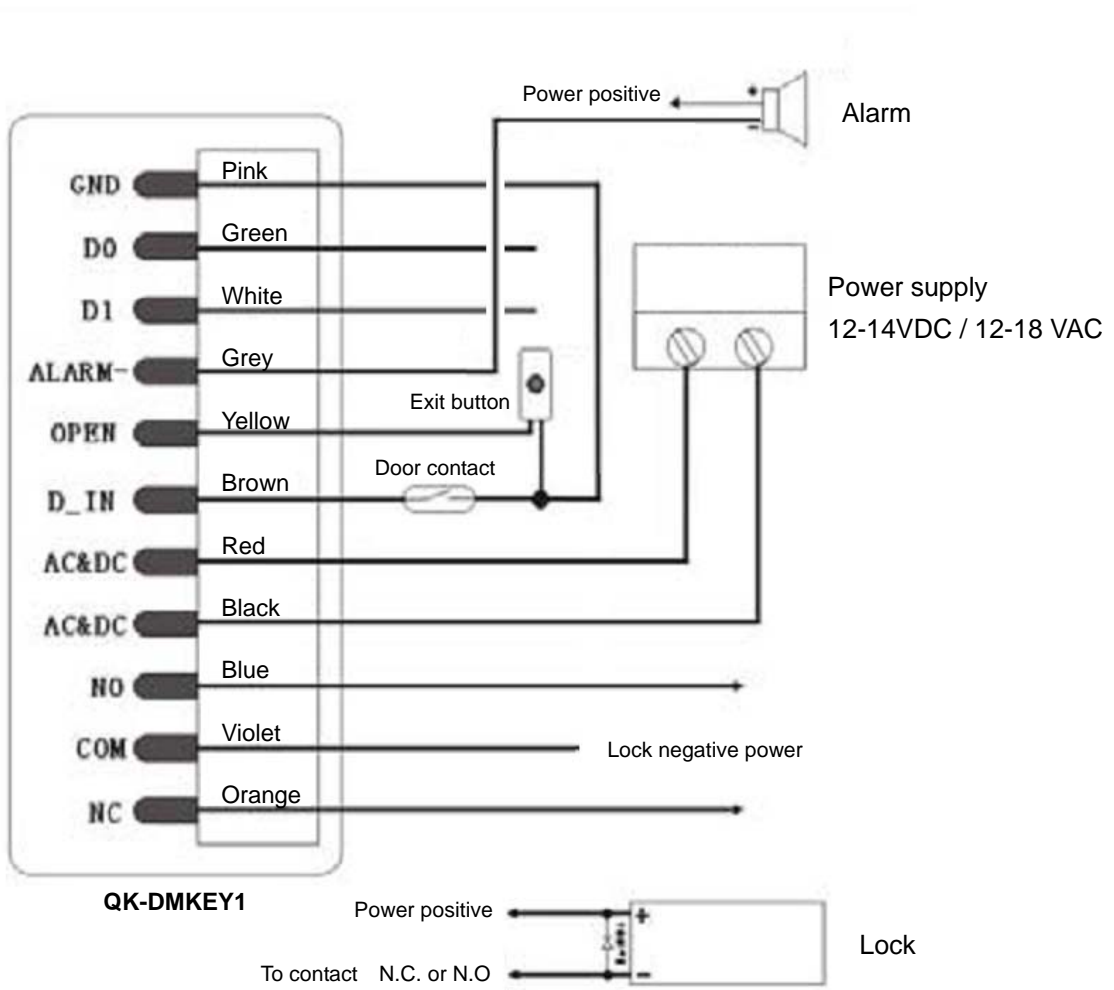

Notes:

Connect the negative pole of the lock to NC is for Fail safe lock.

Connect the negative pole of the lock to NO is for Fail-secure lock.

7. To Reset to Factory Default

To reset to factory default, power off, press  , hold it and power on, release it until hear two beeps and the LED shines in orange, then read any two EM cards, the LED will turn in red, means reset to factory default setting successfully. Of the two EM cards read, the first one is Manager Add card, the second one is Manager Delete card.

Remarks: Upon reset to factory default, the user's information is still retained.

8. Anti Tamper Alarm

The QK-DMKEY1 uses a LDR (light dependent resistor) as an anti tamper alarm. If the keypad is removed from the cover then the tamper alarm will operate.

9. Sound and Light indication

Operation Status	Red Light	Green Light	Yellow Light	Buzzer
Power on	Bright	-	-	Short Ring
Stand by	Bright	-	-	-
Press keypad	-	-	-	Short Ring
Operation successful	-	Bright	-	Short Ring
Operation failed	-	-	-	3 Short Rings
Enter into programming mode	Bright	-	-	Short Ring
In the programming mode	-	-	Bright	-
Exit from the programming mode	Bright	-	-	Short Ring
Open the door	-	Bright	-	Short Ring
Alarm	Bright	-	-	Alarm

10. QK-DMKEY1 Detailed Programming Guide

10.1 User Settings

To enter the programming mode	* Master code # 888888 is the default factory master code
To exit from the programming mode	*
Note that to undertake the following programming the master user must be logged in	
To change the master code	0 New code # New code # The master code is any 6 digits
Setting the working mode: Set valid card only users Set valid card and PIN users Set valid card or PIN users	3 0 # Entry is by card only 3 1 # Entry is by card and PIN together 3 2 # Entry is by either card or PIN (default)
To add a user in either card or PIN mode (3 2 #) (Default setting)	
To add a PIN user	1 User ID number # PIN # The ID number is any number between 1 ~ 2000. The PIN is any 4~8 digits between 0000 ~ 99999999 with the exception of 1234 which is reserved. Users can be added continuously without exiting from programming mode as follows: 1 User ID no 1 # PIN # User ID no 2 # PIN #
To delete a PIN user	2 User ID number # Users can be deleted continuously without exiting programming mode
To change the PIN of a PIN user (This step must be done out of programming mode)	* ID number # Old PIN # New PIN # New PIN #
To add a card user (Method 1) This is the fastest way to enter cards using ID number auto generation.	1 Read card # Cards can be added continuously without exiting programming mode
To add a card user (Method 2) This is the alternative way to enter cards using User ID Allocation. In this	1 ID number # Card #

method a User ID is allocated to a card. Only one user ID can be allocated to a single card.	
To add card user (Method 3) Add a series cards users – Block Enrollment	5 ID number # 8 digits Card number # Card quantity # Card quantity is between 1 ~ 2000. The 8 digits card number is the last 8 digits on the card. Maximum 2000 cards can be enrolled at a stretch within 2 minutes.
To delete a card user by card number. Note users can be deleted continuously without exiting programming mode	2 Read Card #
To delete a card user by user ID. This option can be used when a user has lost their card	2 User ID #
To add a card and PIN user in card and PIN mode (3 1 #)	
To Add a card and Pin user (The PIN is any 4~8 digits between 0000 & 99999999 with the exception of 1234 which is reserved.)	Add the card as for a card user Press * to exit from the programming mode Then allocate the card a PIN as follows: * Read card 1234 # PIN # PIN #
To change a PIN in card and PIN mode (Method 1) Note that this is done outside programming mode so the user can undertake this themselves	* Read Card Old PIN # New PIN # New PIN #
To change a PIN in card and PIN mode (Method 2) Note that this is done outside programming mode so the user can undertake this themselves	* ID number # Old PIN # New PIN # New PIN #
To delete a Card and PIN user just delete the card	2 User ID #
To add a card user in card mode (3 0 #)	
To Add and Delete a card user	The operating is the same as adding and deleting a card user in 3 2 #
To delete All users	

To delete ALL users . Note that this is a dangerous option so use with care	2 0000 #
---	----------

To set card users by Manager card	
To add user by Manager Add Card	Manager add card Read card Manager add card Cards can be added continuously.
To delete User by Manager Delete Card	Manager delete card Read Card Manager delete card Cards can be deleted continuously.

To unlock the door	
For a PIN user	Enter the PIN then press #
For a card User	Read card
For a card and PIN user	Read card then enter PIN #

10.2 Door Relay, Door Detecting, Alarm Settings

Door relay time setting	
To set door relay strike time	4 0~99 # The door relay time is between 0~99 seconds, the factory default setting is 5 seconds.
Door Open Detection	
<i>Door Open Too Long (DOTL) warning.</i> When used with an optional magnetic contact or built-in magnetic contact of the lock, if the door is opened normally, but not closed after 1 minute, the inside buzzer will beep automatically to remind people to close the door and continue for 1 minute before switching off automatically.	
<i>Door Forced Open warning.</i> When used with an optional magnetic contact or built-in magnetic contact of the lock, if the door is opened by force, or if the door is opened after 20 seconds of the electro-mechanical lock not closed properly, the inside buzzer and alarm output will both operate. The Alarm Output time is adjustable between 0~3 minutes with the default being 1 minute.	
To disable door open detection. (Factory default)	6 0 #
To enable door open detection	6 1 #
Alarm output time	
To set the alarm output time (0~3	9 0~3 #

minutes) Factory default is 1 minute	
Keypad Lockout & Alarm Output options. If there are 10 invalid cards or 10 incorrect PIN numbers in a 10 minute period either the keypad will lockout for 10 minutes or the alarm will operate for 10 minutes, depending on the option selected below.	
Normal status: No keypad lockout or alarm (factory default)	7 0 # (Factory default setting)
Keypad Lockout	7 1 #
Alarm Output	7 2 #
To remove the alarm	
To reset the Door Forced Open warning	Read valid card or Master Code #
To reset the Door Open Too Long warning	Close the door or Read valid card or Master Code #

11. Interconnecting Two Devices

11.1 QK-DMKEY1 operating as a Wiegand Output Reader

In this mode the QK-DMKEY1 supports a Wiegand 26 bit output so the Wiegand data lines can be connected to any controller which supports a Wiegand 26 bit input. See figure 1.

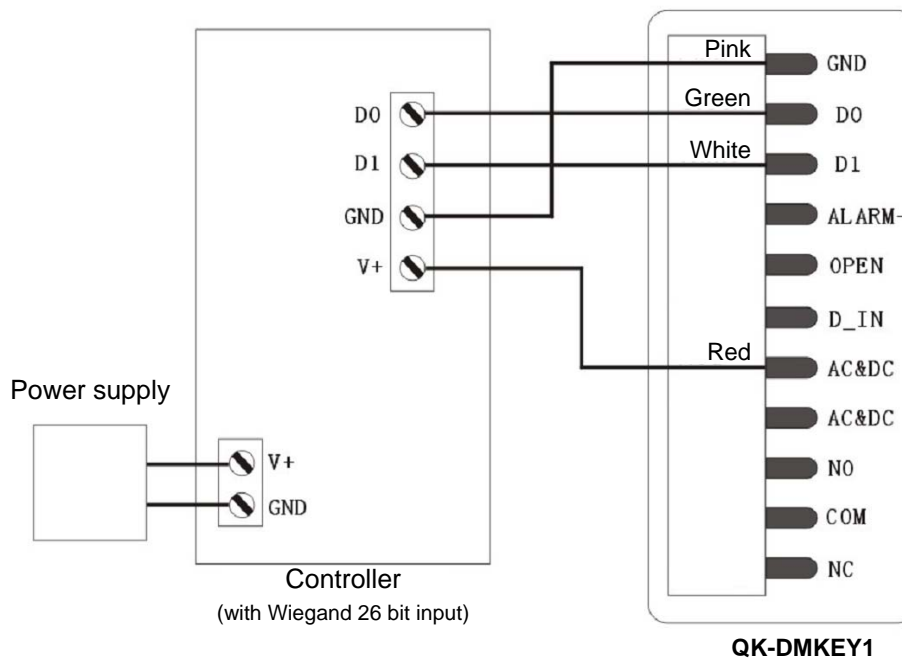

Figure 1

Transmission Format:

◆ 1: Keypad Transmission

The Reader will transmit the PIN data when it receives the last key (#) press after PIN code.

Format: PIN Code (any 4~8 digits between 0000 ~ 99999999)

Example: PIN code: 111111

Press 111111 #, then the output format will be: 00111111

(Note: if press an invalid PIN (any 4~8 digits), the data will be also transmitted.)

◆ 2: Proximity Card Transmission

The Reader will transmit the card data when it reads the Card.

Format: Card Number (the last 8 digits of Card Number)

(Note: no matter the card is valid or invalid, the data will be transmitted)

11.2 QK-DMKEY1 operating as a Controller

In this mode the QK-DMKEY1 supports a Wiegand 26 bit input so an external Wiegand device with a 26 bit output can be connected to the Wiegand input terminals on the QK-DMKEY1. Either an ID card reader (125 KHZ) or an IC card reader (13.56MHZ) can be connected to the QK-DMKEY1. Cards are required to be added at the external reader, except where an external EM reader is used, in this case cards can be added at either reader or controller. See figure 2.

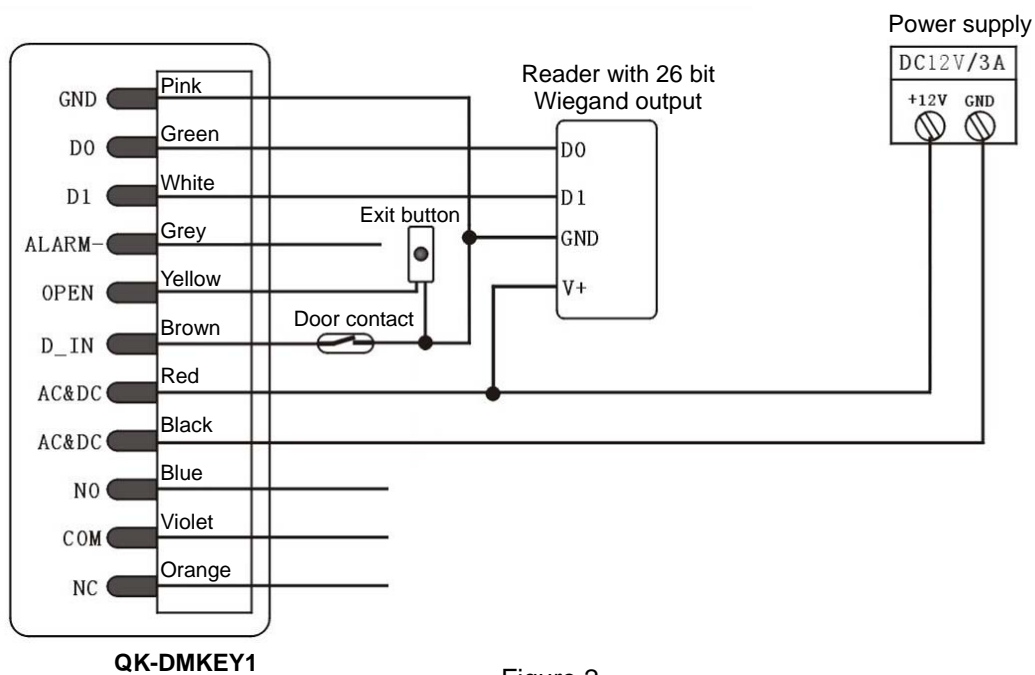

Figure 2

QK-DMKEY1 Quick Reference Programming Guide

To enter the programming mode	* [Master code] # 888888 is the default factory master code
To exit from the programming mode	*
Note that to undertake the following programming the master user must be logged in	
To change the master code	0 [New code] # [New code] # The master code can be 6 digits long
To add a PIN user	1 [User ID number] # [PIN] # The ID number is any number between 1 ~ 2000. The PIN is any 4~8 digits between 0000 ~ 99999999 with the exception of 1234 which is reserved. Users can be added continuously without exiting programming mode
To add a card user	1 [Read Card] # Cards can be added continuously without exiting from programming mode
To delete a PIN or a card user.	2 [User ID number] # for a PIN user or 2 [Read Card] # for a card user Users can be deleted continuously without exiting from programming mode
To unlock the door	
To unlock the door for a PIN user	Enter the [PIN] then press #
To unlock the door for a card user	Present the card

Quiko Italy
Via Seccalegno, 19
36040 Sossano (VI) – Italy
Tel. +39 0444 785513
Fax +39 0444 782371
info@quiko.biz
www.quikoitaly.com

