

ERCOLE

Easy to install, QUIKO ERCOLE series sliding gate operators are the perfect choice to automate heavy duty industrial gates (max 2500kg). The frontal manual release lever allows the user to manually handle the gate in case of emergency, for example, during electrical black-outs. The proper operation of the motor is guaranteed for long time thanks to the sturdy materials used for its production. Wear and tear of the internal mechanical parts is kept to the minimum since the reducer is highly lubricated with oil. QUIKO ERCOLE series gearmotors can handle sliding gates of large sizes and are therefore suitable for intensive use in industrial applications. Everything takes place safely: crash prevention is guaranteed by mechanical clutch indeed.

Semplici da installare, i motoriduttori QUIKO della serie ERCOLE costituiscono la giusta scelta per l'automatizzazione di cancelli industriali di elevato peso (max 2500kg). La leva di sblocco frontale consente all'utente di movimentare il cancello manualmente per bypassare casi di emergenza, come per esempio i black-out elettrici. Il corretto funzionamento del motoriduttore negli anni è garantito dalla robustezza dei materiali utilizzati per la sua costruzione. L'usura della meccanica interna è ridotta al minimo mediante l'elevata lubrificazione del riduttore, che avviene a olio. La serie di motoriduttori ERCOLE di QUIKO riesce a movimentare cancelli scorrevoli di notevoli dimensioni ed è quindi adatta ad un utilizzo intensivo in campo industriale. Il tutto avviene in totale sicurezza grazie alla frizione meccanica antisciacchiamento.

Simple to install, the operators QUIKO de la série ERCOLE constituent le juste choix pour l'automatisation de tous les types de portails coulissants industriels avec poids élevé (max 2500kg). Le levier de déblocage frontal permet à l'utilisateur de déverrouiller le portail en cas d'urgence, comme par exemple les manques d'électricité. Le fonctionnement correct de l'opérateur à long temps est garanti par la robustesse des matériaux utilisés pour sa construction. L'usure de la mécanique est réduite grâce à la lubrification du réducteur avec l'huile. La série des opérateurs ERCOLE de QUIKO réussit à manœuvrer des portails coulissants de grandes dimensions et il est donc apte à une utilisation intensive dans le domaine industriel. Le tout en sécurité totale grâce à la friction mécanique anti-écrasement.



Quiko Italy
Via Seccalegno, 19
36040 Sossano (VI) - Italy
Tel. +39 0444 785513
Fax +39 0444 782371
info@quikoitaly.com
www.quikoitaly.com



MADE IN ITALY

quiklö
opening solutions

QUIKO can technically improve the quality of its products without any prior notice.

QUIKO può apportare ai suoi prodotti modifiche tecniche, migliorative della qualità, senza preavviso.

Quiko se réserve le droit d'apporter des modifications et améliorations techniques sans préavis.

© 2019 Quiko Italy. All rights reserved
V03

© 2019 Quiko Italy. All rights reserved

quiklö
opening solutions

ERCOLE

QK-E2500 230Vac max 2500kg
QK-E2500T 400Vac max 2500kg 3phase

NEW: INVERTER VERSION FOR HIGH SPEED FOR SECURITY APPLIANCES
 20 m/MIN

QK-E2500INV 230Vac max 2500kg
QK-E2500TINV 230Vac max 2500kg 3phase

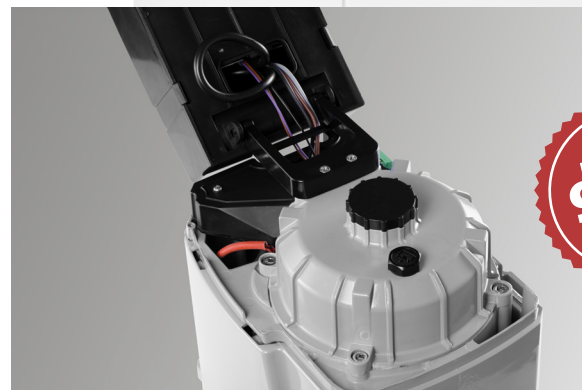
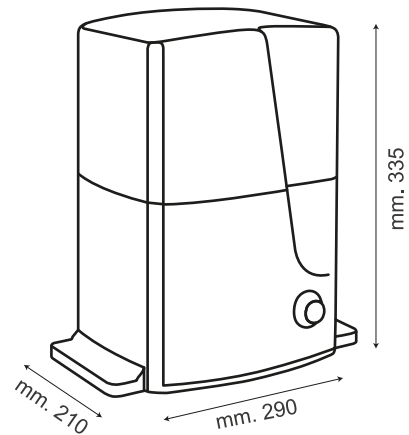

Oil bath gearmotor
 Motoriduttore in bagno d'olio
 Motoréducteur à bain d'huile

TECHNICAL FEATURES	DATI TECNICI	DONNEES TECHNIQUES	HIGH SPEED			
			QK-E2500	QK-E2500T	QK-E2500INV	QK-E2500TINV
Power	Alimentazione	Alimentation	230Vac 50 / 60Hz	400Vac 3phase 50 / 60Hz	230Vac 50 / 60Hz	230Vac 3phase 50 / 60Hz
Current absorbed (motor) (A)	Assorbimento motore (A)	Intensité (A)	2,4	2,4	2,4	2,4
Power absorbed (W)	Potenza assorbita (W)	Puissance absorbée (W)	650	650	650	650
Capacitor (µF)	Condensatore (µF)	Condensateur (µF)	25	-	25	-
Protection level (IP)	Grado di protezione (IP)	Indice de protection (IP)	54	54	54	54
Speed (m/min)	Velocità (m/min)	Vitesse (m/min)	12	12	12-20	12-20
Max. gate weight (kg)	Peso max. cancello (kg)	Poids maxi portail (kg)	2500	2500	2500	2500
Working temp. (°C Min/Max)	Temp. di esercizio (°C Min/Max)	Temp. de service (°C Min/Max)	-30/+70	-30/+70	-30/+70	-30/+70
Thermal protection (°C)	Termoprotezione (°C)	Protection thermique (°C)	130	130	130	130
Insulation class	Classe di isolamento	Classe d'isolation	F	F	F	F
Working cycle (%)	Ciclo di lavoro (%)	Cycle de travail (%)	90	90	90	90
Weight (kg)	Peso (kg)	Poids (kg)	19	19	19	19

KIT	QK-E2500KIT	230Vac	max 2500kg
	QK-E2500TKIT	400Vac 3phase	max 2500kg
NEW	QK-E2500KITINV	230Vac	max 2500kg HIGH SPEED 20m/min with INVERTER
	QK-E2500TKITINV	230Vac 3phase	max 2500kg HIGH SPEED 20m/min with INVERTER

20 PCS PALLET



KIT LIGHT

KIT FULL

Gearmotor, control board with 433,92MHz receiver and antenna + Counterplate + 4 channel transmitter + Pair of IR photocells + Flashing lamp + Key switch

Motoriduttore, centrale con radiorecivente 433,92MHz e antenna + Contropiastra + Telecomando quadricanale + Coppia di fotocellule IR + Lampeggiante + Selettore a chiave

Motoréducteur, logique de commande avec récepteur radio 433,92MHz et antenne + Patte de fixation + Emetteur 4 canaux + Jeu de photocellules IR + Feu clignotant + Sélecteur à clé

The content of the package may vary: consult the retailer
 Il contenuto della confezione potrebbe variare: contattare il rivenditore
 Le contenu du paquet peut varier: contactez revendeur

OPTIONALS



QK-CE220RLX

400V control board with 433,92MHz radioreceiver

Centrale 400V con radiorecivente 433,92MHz

Logique de commande 400V avec récepteur 433,92MHz



QK-CE220RLINV

230V control board with 433,92MHz radioreceiver with INVERTER

Centrale 230V con radiorecivente 433,92MHz con INVERTER

Logique de commande 230V avec récepteur 433,92MHz avec INVERTER

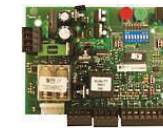

QK-CE220CN

230V control board with 433,92MHz radioreceiver

Centrale 230V con radiorecivente 433,92MHz

Logique de commande 230V avec récepteur 433,92MHz

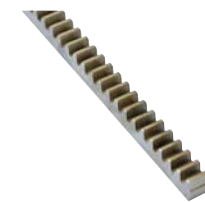

QK-CRF2222

22x22x1000 iron rack (M4). Weld mount

Cremaigliera in ferro 22x22x1000 (M4). A saldare

Crémaillère acier 22x22x1000 (M4). À souder



QK-CRF3012

30x12x1000 iron rack (M4). Screw mount

Cremaigliera in ferro 30x12x1000 (M4). Ad avvitare

Crémaillère acier 30x12x1000 (M4). À visser